

# MOUNTING AND OPERATING INSTRUCTIONS



## EB 2559 EN

### Translation of original instructions



Type 2357-3 with non-return unit at Port C  
Ports A and B with solder nipple with ball-type bushing



Type 2357-3 made of CrNi steel  
(special version)

## Type 2357-3 Pressure Build-up Regulator

Self-operated Pressure Regulators · Cryogenic

Edition August 2022



## Note on these mounting and operating instructions

These mounting and operating instructions assist you in mounting and operating the device safely. The instructions are binding for handling SAMSON devices. The images shown in these instructions are for illustration purposes only. The actual product may vary.

- For the safe and proper use of these instructions, read them carefully and keep them for later reference.
- If you have any questions about these instructions, contact SAMSON's After-sales Service (aftersaleservice@samsongroup.com).



The mounting and operating instructions for the devices are included in the scope of delivery. The latest documentation is available on our website at [www.samsongroup.com](http://www.samsongroup.com) > **Service & Support** > **Downloads** > **Documentation**.

## Definition of signal words

### **DANGER**

*Hazardous situations which, if not avoided, will result in death or serious injury*

### **WARNING**

*Hazardous situations which, if not avoided, could result in death or serious injury*

### **NOTICE**

*Property damage message or malfunction*

### **Note**

*Additional information*

### **Tip**

*Recommended action*

<b>1</b>	<b>Safety instructions and measures</b> .....	<b>1-1</b>
1.1	Notes on possible severe personal injury .....	1-4
1.2	Notes on possible personal injury .....	1-5
1.3	Notes on possible property damage .....	1-6
<b>2</b>	<b>Markings on the device</b> .....	<b>2-1</b>
2.1	Nameplate .....	2-1
2.2	Material identification number .....	2-1
<b>3</b>	<b>Design and principle of operation</b> .....	<b>3-1</b>
3.1	Additional fittings .....	3-3
3.2	Technical data .....	3-4
<b>4</b>	<b>Shipment and on-site transport</b> .....	<b>4-1</b>
4.1	Accepting the delivered goods .....	4-1
4.2	Removing the packaging from the regulator .....	4-1
4.3	Transporting and lifting the regulator .....	4-1
4.4	Storing the regulator .....	4-2
<b>5</b>	<b>Installation</b> .....	<b>5-1</b>
5.1	Installation conditions .....	5-1
5.2	Preparation for installation .....	5-3
5.3	Installation .....	5-3
5.3.1	Installing the regulator .....	5-4
5.3.2	Cleaning the pipeline .....	5-4
5.4	Testing the regulator .....	5-4
5.4.1	Leak test .....	5-5
5.4.2	Pressure test .....	5-6
<b>6</b>	<b>Start-up</b> .....	<b>6-1</b>
6.1	Start-up and putting the device back into operation .....	6-2
6.2	Starting up the plant .....	6-2
<b>7</b>	<b>Operation</b> .....	<b>7-1</b>
7.1	Adjusting the set point .....	7-1
<b>8</b>	<b>Malfunctions</b> .....	<b>8-1</b>
8.1	Troubleshooting .....	8-1
8.2	Emergency action .....	8-2
<b>9</b>	<b>Servicing</b> .....	<b>9-1</b>
9.1	Preparing the valve for service work .....	9-4
9.2	Installing the regulator after service work .....	9-4
9.3	Service work .....	9-4

## Contents

9.4	Replacing the set point spring .....	9-4
9.5	Ordering spare parts and operating supplies .....	9-6
<b>10</b>	<b>Decommissioning .....</b>	<b>10-1</b>
<b>11</b>	<b>Removal .....</b>	<b>11-1</b>
11.1	Removing the regulator from the pipeline .....	11-1
11.2	Removing the actuator from the valve .....	11-1
<b>12</b>	<b>Repairs .....</b>	<b>12-1</b>
12.1	Returning devices to SAMSON .....	12-1
<b>13</b>	<b>Disposal.....</b>	<b>13-1</b>
<b>14</b>	<b>Certificates.....</b>	<b>14-1</b>
<b>15</b>	<b>Annex.....</b>	<b>15-1</b>
15.1	Tightening torques.....	15-1
15.2	Lubricant .....	15-2
15.3	Tools .....	15-2
15.4	Spare parts .....	15-2
15.5	Accessories .....	15-2
15.6	After-sales service .....	15-2

# 1 Safety instructions and measures

## Intended use

The SAMSON Type 2357-3 Regulator is a pressure regulator. The regulator is designed to keep the pressure (either downstream pressure  $p_2$  or upstream pressure  $p_1$ , depending on the version) constant to the adjusted set point, especially in cryogenic plants. Liquids, gases and vapors in processing and industrial plants can be controlled by the regulator.

The regulators are designed to operate under exactly defined conditions (e.g. operating pressure, process medium, temperature). Therefore, operators must ensure that the regulators are only used in operating conditions that meet the specifications used for sizing the devices at the ordering stage. In case operators intend to use the regulators in applications or conditions other than those specified, contact SAMSON.

SAMSON does not assume any liability for damage resulting from the failure to use the device for its intended purpose or for damage caused by external forces or any other external factors.

→ Refer to the technical data and nameplate for limits and fields of application as well as possible uses.

## Reasonably foreseeable misuse

The regulators are not suitable for the following applications:

- Use outside the limits defined during sizing and by the technical data
- Use outside the limits defined by the additional fittings mounted on the regulator

Furthermore, the following activities do not comply with the intended use:

- Use of non-original spare parts
- Performing service and repair work not described

## Qualifications of operating personnel

The regulator must be mounted, started up, serviced and repaired by fully trained and qualified personnel only; the accepted industry codes and practices must be observed. According to these mounting and operating instructions, trained personnel refers to individuals who are able to judge the work they are assigned to and recognize possible hazards due to their specialized training, their knowledge and experience as well as their knowledge of the applicable standards.

## Safety instructions and measures

### Safety features

The Type 2357-3 Regulator does not have any special safety features. When relieved of pressure, the regulator is opened by the force of the set point springs.

### Personal protective equipment

We recommend checking the hazards posed by the process medium being used (e.g.

▶ GESTIS (CLP) hazardous substances database). Depending on the process medium and/or the activity, the protective equipment required includes:

- ➔ Protective clothing, safety gloves and eye protection in applications with hot, cold and/or corrosive media
- ➔ Wear hearing protection when working near the valve
- ➔ Check with the plant operator for details on further protective equipment.

### Revisions and other modifications

Revisions, conversions or other modifications of the product are not authorized by SAMSON. They are performed at the user's own risk and may lead to safety hazards, for example. Furthermore, the product may no longer meet the requirements for its intended use.

### Warning against residual hazards

To avoid personal injury or property damage, plant operators and operating personnel must prevent hazards that could be caused in the regulator by the process medium, the operating pressure or by moving parts by taking appropriate precautions. Plant operators and operating personnel must observe all hazard statements, warning and caution notes in these mounting and operating instructions.

Hazards resulting from the special working conditions at the installation site of the regulator must be identified in a risk assessment and prevented through the corresponding safety instructions drawn up by the operator.

We also recommend checking the hazards posed by the process medium being used (e.g.

▶ GESTIS (CLP) hazardous substances database).

- ➔ Observe safety measures for handling the device as well as fire prevention and explosion protection measures.

### Responsibilities of the operator

Operators are responsible for proper use and compliance with the safety regulations. Operators are obliged to provide these mounting and operating instructions as well as the referenced documents to the operating personnel and to instruct them in proper operation. Furthermore, operators must ensure that operating personnel or third parties are not exposed to any danger.

Operators are additionally responsible for ensuring that the limits for the product defined in the technical data are observed. This also applies to the start-up and shutdown procedures. Start-up and shutdown procedures fall within the scope of the operator's duties and, as such, are not part of these mounting and operating instructions. SAMSON is unable to make any statements about these procedures since the operative details (e.g. differential pressures and temperatures) vary in each individual case and are only known to the operator.

### Responsibilities of operating personnel

Operating personnel must read and understand these mounting and operating instructions as well as the referenced documents and observe the specified hazard statements, warnings and caution notes. Furthermore, operating personnel must be familiar with the applicable health, safety and accident prevention regulations and comply with them.

### Referenced standards, directives and regulations

The regulators comply with the requirements of the European Pressure Equipment Directive 2014/68/EU and the European Machinery Directive 2006/42/EC. Regulators with a CE marking have an EU declaration of conformity, which includes information about the applied conformity assessment procedure. This EU declaration of conformity is included in the 'Certificates' section.

According to the ignition hazard assessment performed in accordance with Clause 5.2 of ISO 80079-36, the non-electrical regulators do not have their own potential ignition source even in the rare incident of an operating fault. As a result, they do not fall within the scope of Directive 2014/34/EU.

➔ For connection to the equipotential bonding system, observe the requirements specified in Clause 6.4 of EN 60079-14 (VDE 0165-1).

## Safety instructions and measures

### Referenced documentation

The following documents apply in addition to these mounting and operating instructions:

- Manuals

e.g. **Oxygen manual** ▶ H 01

---

- Data sheets for

e.g. **Spare parts and accessories · Self-operated regulators for cryogenic media** ▶ T 2570

---

- Mounting and operating instructions as well as data sheets for additional fittings (e.g. shut-off valves, pressure gauges etc.).

## 1.1 Notes on possible severe personal injury

### DANGER

#### **Risk of bursting in pressure equipment.**

Regulators and pipelines are pressure equipment. Impermissible pressure or improper opening can lead to regulator components bursting.

- Observe the maximum permissible pressure for regulator and plant.
- Before starting any work on the regulator, depressurize all plant sections affected as well as the regulator.
- Drain the process medium from all the plant sections affected as well as the regulator.
- Wear personal protective equipment.



## 1.2 Notes on possible personal injury

### WARNING

#### **Damage to health relating to the REACH regulation.**

If a SAMSON device contains a substance which is listed as being a substance of very high concern on the candidate list of the REACH regulation, this circumstance is indicated on the SAMSON delivery note.

- Information on safe use of the part affected ► [www.samsongroup.com/reach-en.html](http://www.samsongroup.com/reach-en.html).

#### **Risk of personal injury through incorrect operation, use or installation as a result of information on the regulator being illegible.**

Over time, markings, labels and nameplates on the regulator may become covered with dirt or become illegible in some other way. As a result, hazards may go unnoticed and the necessary instructions not followed. There is a risk of personal injury.

- Keep all relevant markings and inscriptions on the device in a constantly legible state.
- Immediately renew damaged, missing or incorrect nameplates or labels.

#### **Risk of burn injuries due to hot or cold components and pipelines.**

Depending on the process medium, regulator components and pipelines may get very hot or cold and cause burn injuries.

- Allow components and pipelines to cool down or warm up to the ambient temperature.
- Wear protective clothing and safety gloves.

#### **Risk of personal injury due to residual process medium in the regulator.**

While working on the regulator, residual process medium can escape and, depending on its properties, may lead to personal injury, e.g. (chemical) burns.

- If possible, drain the process medium from all the plant sections affected and the regulator.
- Wear protective clothing, safety gloves and eye protection.

## 1.3 Notes on possible property damage

### ! NOTICE

#### **Risk of regulator damage due to incorrectly attached slings.**

- Do not attach load-bearing slings to the regulator.

#### **Risk of regulator damage due to unsuitable medium properties.**

The regulator is designed for a process medium with defined properties.

- Only use the process medium specified for sizing the equipment.

#### **Risk of regulator damage due to contamination (e.g. solid particles) in the pipeline.**

The plant operator is responsible for cleaning the pipelines in the plant.

- Flush the pipelines before start-up.

#### **Risk of regulator damage due to the use of unsuitable lubricants.**

The lubricants to be used depend on the regulator material. Unsuitable lubricants may corrode and damage surfaces.

- Only use lubricants approved by SAMSON.  
When in doubt, consult SAMSON.

#### **Risk of leakage and regulator damage due to excessively high or low tightening torques.**

Observe the specified torques when tightening regulator components. Excessive tightening torques lead to parts wearing out more quickly. Parts that are too loose may cause leakage.

- Observe the specified tightening torques (see 'Tightening torques' in Annex).

#### **Risk of regulator damage due to the use of unsuitable tools.**

Certain tools are required to work on the regulator.

- Only use tools approved by SAMSON.  
When in doubt, consult SAMSON.

---

### i Note

*SAMSON's After-sales Service can support you concerning lubricant, tightening torques and tools approved by SAMSON.*

---

## 2 Markings on the device

### 2.1 Nameplate

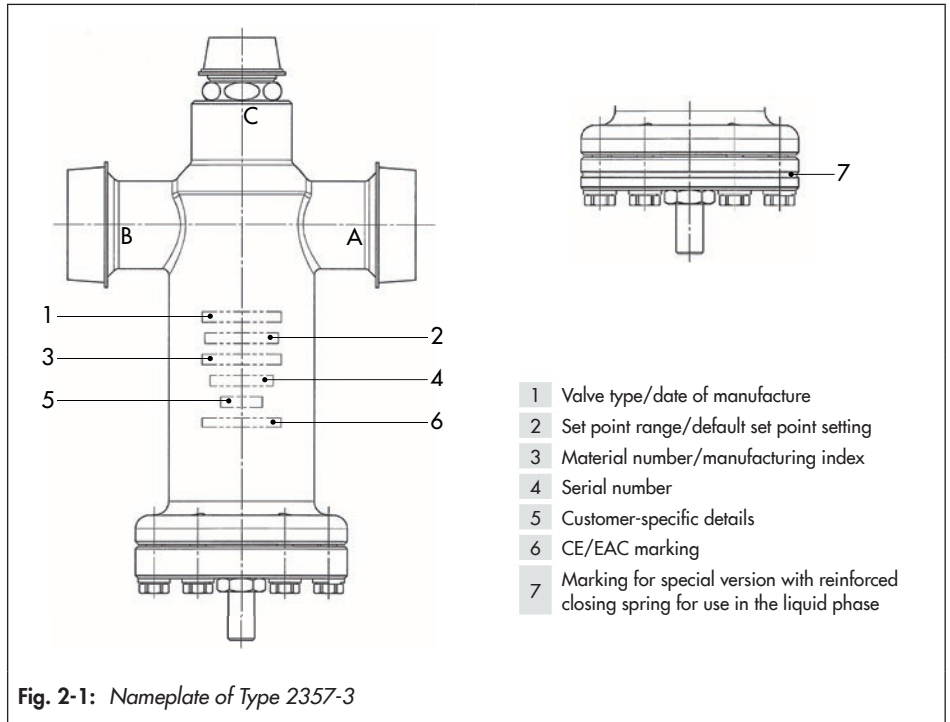

### 2.2 Material identification number

Specifying the material number, you can contact us to find out which material is used.

The configuration ID is specified on the nameplate (3).

For more details on the nameplate, see section 2.1.



### 3 Design and principle of operation

→ See Fig. 3-1

The regulator consists of a valve with three ports (A, B and C), a spring-loaded operating bellows (3) with set point adjuster (10) and a tubular plug (2.2).

The process medium flows from port A to port B in the pressure regulator used as a build-up pressure regulator with safety function.

The regulator is open when relieved of pressure. The pressure downstream of the regulator is transmitted to the operating diaphragm (3). The positioning force produced by this pressure moves the pressure build-up plug (2.1), which is firmly attached to the plug sleeve, depending on the spring force adjustable at the set point adjuster (10). The regulator closes as soon as the downstream pressure has assumed the adjusted set point.

Functioning as a pressure build-up regulator, the regulator also operates as a safety valve for the pressure chamber upstream of port A. When the pressure rises above the set point by approx. 5 bar, the positioning force overcomes the force of the closing spring (16), causing the pressure build-up plug (2.1) to open and the pressure is relieved to ports B and C.

Functioning as an excess pressure valve, the medium flows from port B to C. The tubular plug seals off the operating bellows when there is no pressure drop across port B and C. The pressure at port B acts on the operating bellows (3). The positioning force pro-

duced by this pressure opposes the adjustable spring force of the set point spring (8) and opens the tubular plug (2.2) when the pressure rises above the set point by approx. 0.5 bar. The pressures are equalized and the medium escapes through the inside of the tubular plug over port C.

As an excess pressure valve, the regulator can be optionally equipped with a non-return unit (12). It prevents the medium from flowing back to port C and allows maintenance work to be performed on the regulator without having to empty the tank first.

#### EC type examination

An EC type examination according to the Pressure Equipment Directive 97/23/EC, Module B has been performed on the regulators.

## Design and principle of operation

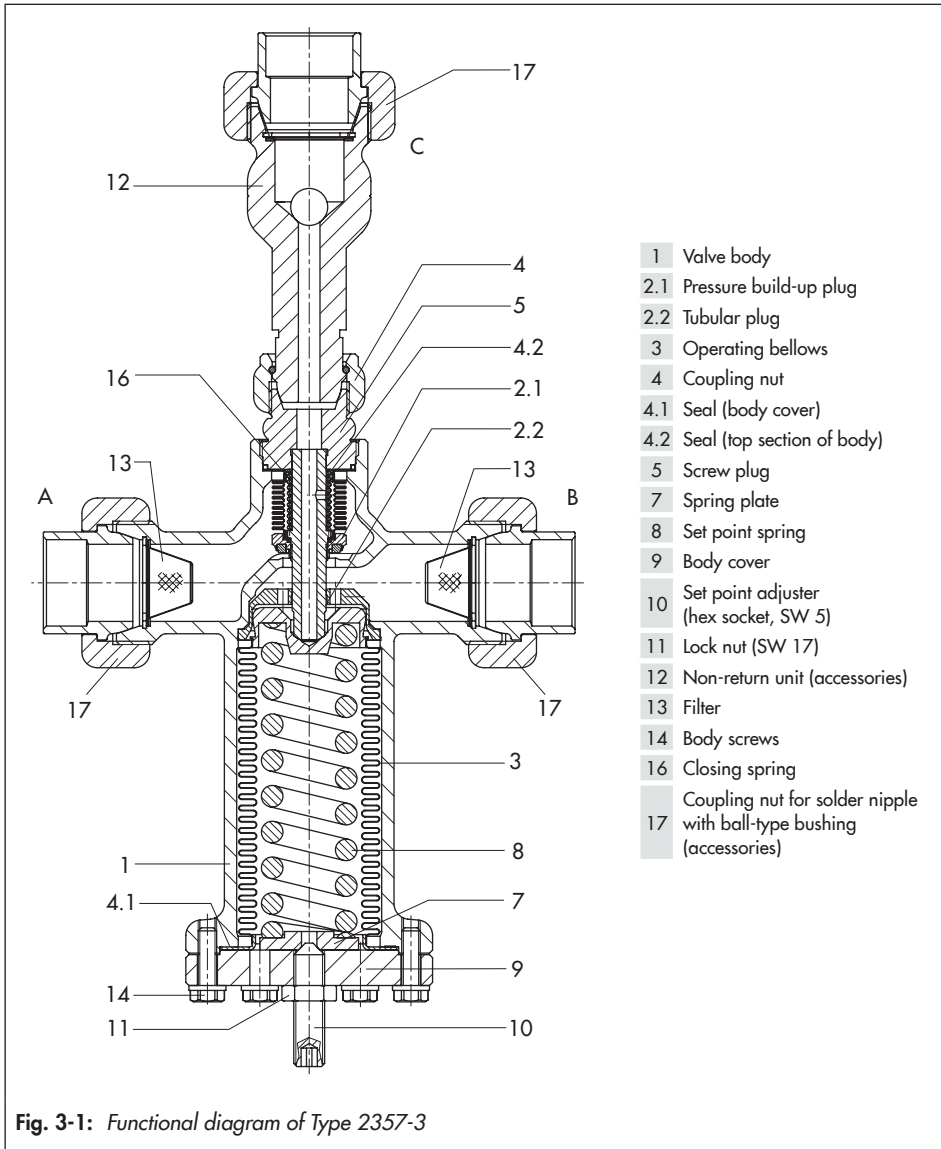

### 3.1 Additional fittings

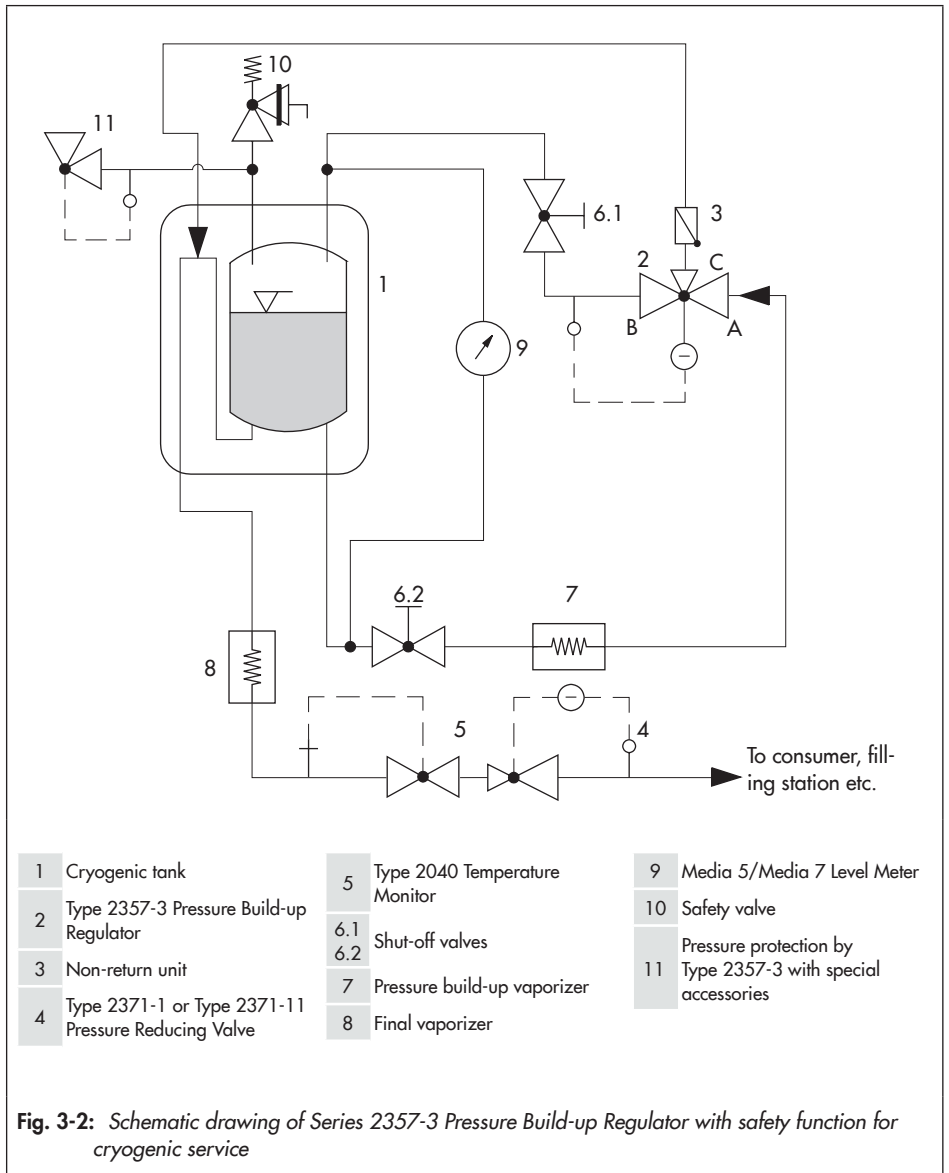

### Shut-off valves

We recommend installing a shut-off valve (1) in each of the inlets and outlets of the regulator. The shut-off valves allow the plant to be shut down for cleaning and maintenance, and when the plant is not used for longer periods of time.

### Insulation

Regulators can be insulated to reduce cooling losses.

Refer to the instructions in the 'Installation' section.

---

#### **i Note**

*The Type 2357-3 Regulator is not a safety valve. If necessary, a suitable overpressure protection must be installed on site in the plant section.*

---

## 3.2 Technical data

The regulator nameplate provides information on the regulator version (see the 'Markings on the device' section).

---

#### **i Note**

*More information is available in Data Sheet ► T 2559.*

---

### Process medium and scope of application

The regulator is designed to keep the pressure constant to the adjusted set point, especially in cryogenic plants.

The regulator functions as a pressure build-up regulator with safety function (direction of flow from A to B, closing) or as an excess pressure valve (direction of flow from B to C, opening).

- Suitable for **cryogenic gases and liquids as well as other liquids, gases and vapors**
- Min. temperature **-196 °C**
- Max. temperature **200 °C**
- Set points from **2 to 40 bar**
- Valve size **DN 25/20**
- Pressure rating **PN 40**



### Noise emissions

SAMSON is unable to make general statements about noise emissions. The noise emissions depend on the regulator version, plant facilities and process medium.

---

**⚠ WARNING**

***Risk of hearing loss or deafness due to loud noise.***

*Wear hearing protection when working near the regulator.*

---

---

**⚠ WARNING**

***Risk of injury and property damage due to high pressure in the plant.***

*A suitable overpressure protection must be installed on site in the plant section.*

---

### Temperature range

Depending on how the regulator is configured, it can be used up to temperatures of  $-196$  to  $200$  ° (Table 3-1).

### Conformity

The Type 2357-3 Regulator bears both the CE and EAC marks of conformity.



### Dimensions and weights

Table 3-1 provides a summary of the weights. The lengths, heights and other dimensions in the dimensional drawings are shown on pages 3-7 and 3-8.

## Design and principle of operation

**Table 3-1:** *Technical data · All pressures in bar (gauge)*

Type	2357-3	
	– Process medium in the gas phase –	– Special version in the liquid phase –
Pressure rating	PN 40	
$K_{VS}$ coefficient	3.2	
Set point range	2 to 10 bar · 8 to 26 bar · 25 to 40 bar	
Fail-safe action	5 bar above the set point	12 bar above the set point
Excess pressure function	0.5 bar above the set point	
Temperature range	(-254 °C) <sup>1)</sup> -196 to +200 °C	
Weight, approx.	3.5 kg	
Conformity		

<sup>1)</sup> Version for liquid hydrogen

**Table 3-2:** *Materials · Material numbers according to DIN EN*

Type	2357-3		
Body	CC754S-GM (brass)	1.4404	
Tubular plug	1.4301	1.4301	
Plug	1.4301 · PTFE soft seal		
Bellows	1.4571		
Set point spring	Stainless steel 1.4310		
Body gasket	PTFE		
Connections	A, B	M40x2	Welding ends 26.9 x 2
	C	M26x1.5 male thread	
	Non-return unit	M40x2	M26x1.5

Dimensions (in mm)

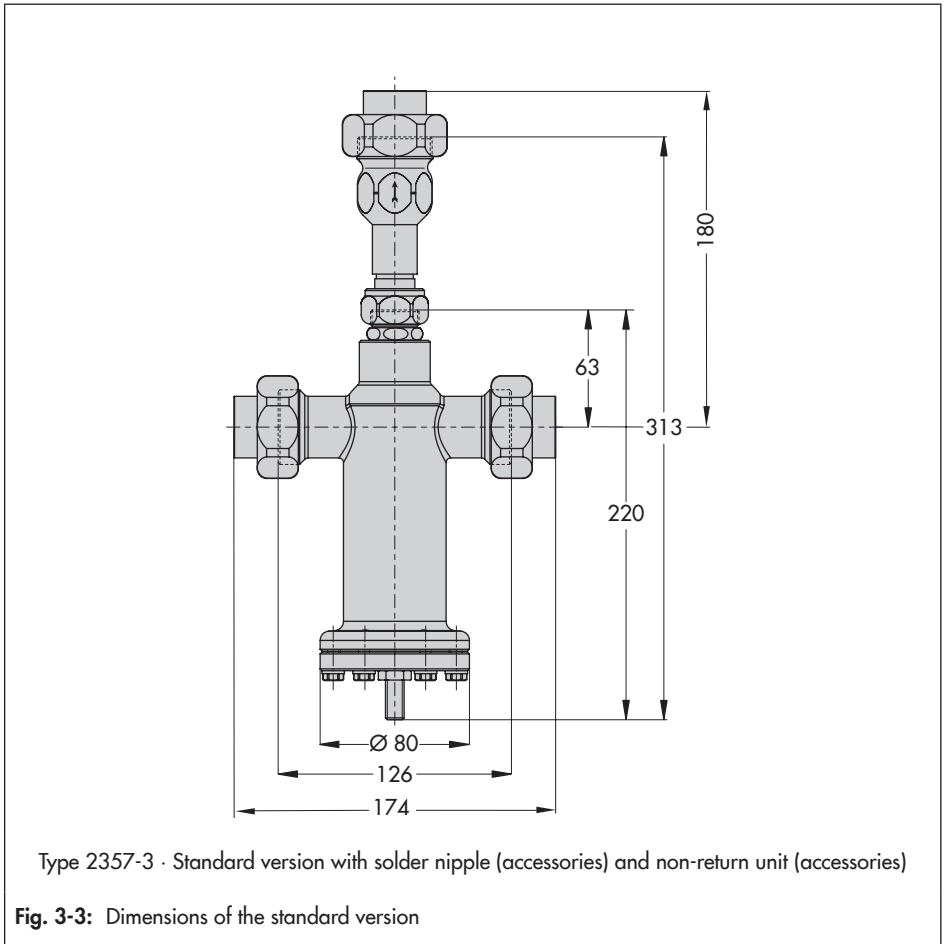

## Design and principle of operation

### Dimensions (in mm)

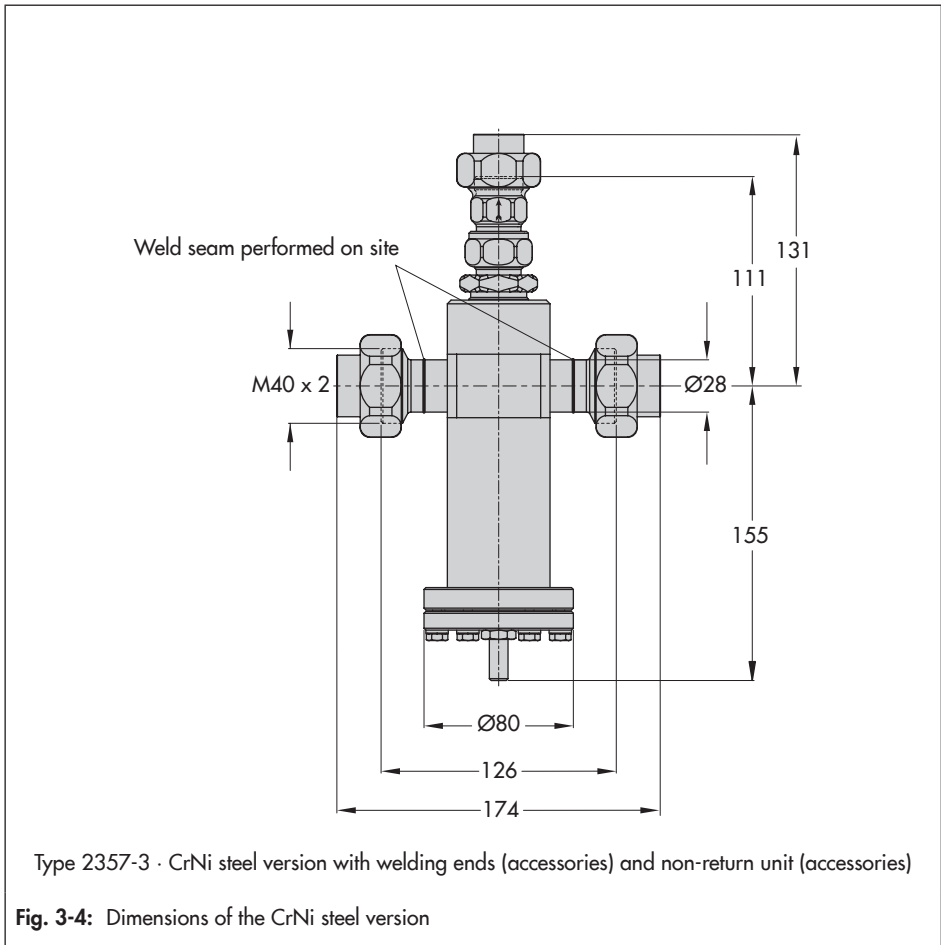

## 4 Shipment and on-site transport

The work described in this section is only to be performed by personnel appropriately qualified to carry out such tasks.

### 4.1 Accepting the delivered goods

After receiving the shipment, proceed as follows:

1. Check the scope of delivery. Check that the specifications on the nameplate and on the regulator itself match the specifications in the delivery note. See the 'Markings on the device' section for nameplate details.
2. Check the shipment for transportation damage. Report any damage to SAMSON and the forwarding agent (refer to delivery note).

#### **i** Note

***In the delivered state, the regulators are packed to be free of oil and grease for oxygen service.***

*Do not open or remove the packaging until immediately before installation.*

### 4.2 Removing the packaging from the regulator

The regulator is delivered as an assembled unit.

- ➔ Do not open or remove the packaging until immediately before lifting to install the regulator into the pipeline.
- ➔ Dispose and recycle the packaging in accordance with the local regulations.

#### **!** NOTICE

***In the delivered state, the regulators are packed to be free of oil and grease for oxygen service.***

*Do not remove the packaging until immediately before installation.*

### 4.3 Transporting and lifting the regulator

Due to the low service weight, lifting equipment is not required to lift and transport the regulator (e.g. to install it into the pipeline).

#### Transport instructions

- ➔ Protect the regulator against external influences (e.g. impact).
- ➔ Do not remove the packaging. Do not open or remove the packaging until immediately before installation in the pipeline.
- ➔ Protect the regulator against moisture and dirt.

## Shipment and on-site transport

- Observe the permissible ambient temperature (see Table 3-1 in the 'Design and principle of operation' section).

## 4.4 Storing the regulator

### NOTICE

#### ***Risk of regulator damage due to improper storage.***

- *Observe the storage instructions.*
- *Avoid long storage times.*
- *Contact SAMSON in case of different storage conditions or longer storage times.*

### Storage instructions

- Protect the regulator against external influences (e.g. impact).
- Secure the regulator in the stored position against slipping or tipping over.
- Do not remove the packaging. Do not remove the packaging until immediately before installation.
- Protect the regulator against moisture and dirt. Store it at a relative humidity of less than 75 %. In damp spaces, prevent condensation. If necessary, use a drying agent or heating.
- Make sure that the ambient air is free of acids or other corrosive media.
- The permissible storage temperature of standard regulators is  $-20$  to  $+65$  °C.
- Do not place any objects on the regulator.

### Note

*We recommend regularly checking the regulator and the prevailing storage conditions during long storage periods.*

### Tip

*SAMSON's After-sales Service can provide more detailed storage instructions on request.*

## 5 Installation

The work described in this section is only to be performed by personnel appropriately qualified to carry out such tasks.

---

**⚠ WARNING*****Explosion hazard due to the use of oil and grease in oxygen atmospheres!***

*Make sure that the regulator is absolutely clean and free of oil and grease on installing it.*

---

In the delivered state, the regulators are packed to be free of oil and grease for oxygen service. Do not open the packaging until immediately before installation.

### 5.1 Installation conditions

#### Work position

The work position for the regulator is the front view onto all operating controls on the regulator (including any additional fittings) seen from the position of operating personnel.

Plant operators must ensure that, after installation of the device, the operating personnel can perform all necessary work safely and easily access the device from the work position.

#### Pipeline routing

The inlet and outlet lengths vary depending on several variables and process conditions.

To ensure that the regulator functions properly, proceed as follows:

- ➔ Install the regulator free of stress and with the least amount of vibrations as possible. Read information under "Mounting position" and "Support or suspension" in this section.
- ➔ Install the regulator allowing sufficient space to remove the actuator and valve or to perform service work on them.

## Installation

### Mounting position

- Install the regulator with the actuator housing suspended downward (with port C facing upward) in horizontal pipelines (see Fig. 5-1).
- Make sure the correct direction of flow is used for the body design and the intended use.

**Pressure build-up regulator** with safety function

Direction of flow from port **A** to port **B**

**Excess pressure valve:**

Direction of flow from port **B** to port **C**

The ports **A** and **B** are marked on the body.

- Install the regulator free of stress.
- Make sure that the regulator remains freely accessible after the plant has been completed.

### Support or suspension

#### **i** Note

*The plant engineering company is responsible for selecting and implementing a suitable support or suspension of the installed regulator and the pipeline.*

Depending on the regulator version and mounting position, the regulator and pipeline must be supported or suspended.

#### **!** NOTICE

*Do not attach supports directly to the regulator.*

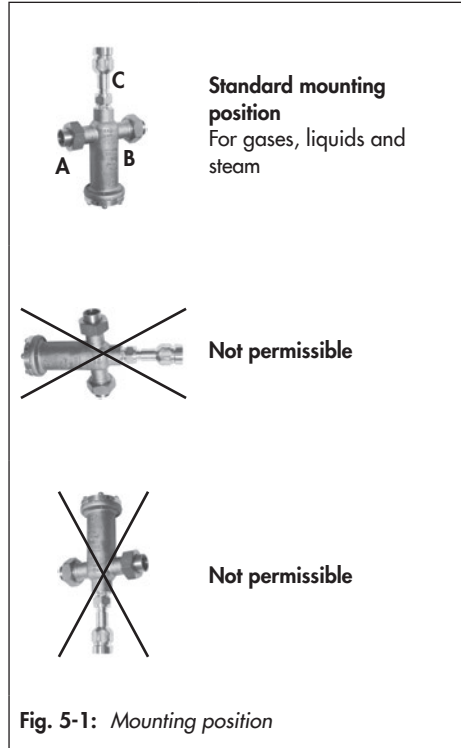



## 5.2 Preparation for installation

Before mounting, make sure the following conditions are met:

- The regulator is clean.
- The regulator and packaging is not damaged.
- The regulator data on the nameplate (type designation, valve size, material, pressure rating and temperature range) match the plant conditions (size and pressure rating of the pipeline, medium temperature etc.). See the 'Markings on the device' section for nameplate details.
- The requested or required additional fittings (see the 'Design and principle of operation' section) have been installed or prepared as necessary before installing the regulator.

Proceed as follows:

- ➔ Lay out the necessary material and tools to have them ready during installation work.
- ➔ Flush the pipeline **before** installing the regulator.  
The plant operator is responsible for cleaning the pipelines in the plant.

## 5.3 Installation

The SAMSON regulator is an assembled unit in the delivered state. The activities listed below are necessary for installation and before start-up of the regulator.

### WARNING

***Explosion hazard due to the use of oil and grease in oxygen atmospheres!***  
*Make sure that the regulator is absolutely clean and free of oil and grease on installing it.*

### NOTICE

***Risk of regulator damage due to the use of unsuitable tools.***

- ➔ *Only use tools approved by SAMSON (see 'Tools' in Annex).*

### NOTICE

***Risk of regulator damage due to excessively high or low tightening torques.***

*Observe the specified torques when tightening regulator components. Excessive tightening torques lead to parts wearing out more quickly. Parts that are too loose may cause leakage.*

- ➔ *Observe the specified tightening torques (see 'Tightening torques' in Annex).*

### 5.3.1 Installing the regulator

1. Close the shut-off valves (6.1 and 6.2) in the pipeline while the valve is being installed.
2. Take the regulator out of the packaging.
3. Lift the regulator to the site of installation. Observe the flow direction through the regulator. Markings on the regulator indicate the direction of installation.
4. Bolt the regulator to the pipeline free of stress.
5. Slowly open the shut-off valves in the pipeline after the regulator has been installed.

### 5.3.2 Cleaning the pipeline

We recommend additionally flushing the pipeline without the installed regulator before start-up. In this case, install a suitable length of pipe into the pipeline in place of the regulator.

- Observe the mesh size of the integrated strainer for the maximum particle size.
- Check the strainer filters for dirt each time the pipeline is flushed and clean them, if necessary.

### 5.4 Testing the regulator

---

#### **⚠ DANGER**

**Risk of bursting due to incorrect opening of pressurized equipment or components.**

*Regulators and pipelines are pressure equipment that may burst when handled incorrectly. Flying projectile fragments or the release of process medium under pressure can cause serious injury or even death.*

*Before working on the regulator:*

- *Depressurize all plant sections concerned and the regulator.*
  - *Drain the process medium from all the plant sections concerned as well as the valve.*
- 

---

#### **⚠ DANGER**

**Risk of personal injury due to process medium escaping.**

- *Do not start up the regulator until all parts have been mounted.*
- 

---

#### **⚠ WARNING**

**Risk of hearing loss or deafness due to loud noise.**

*Noise emission (e.g. cavitation or flashing) may occur during operation caused by the process medium and the operating conditions.*

- *Wear hearing protection when working near the regulator.*
-

---

**⚠ WARNING**

***Risk of burn injuries due to hot or very cold components and pipelines.***

*Depending on the process medium, the regulator and pipelines may get very hot or cold and cause burn injuries.*

➔ *Wear protective clothing and safety gloves.*

---

SAMSON regulators are delivered ready for use. To test the regulator functioning before start-up or putting back the regulator into operation, perform the following tests:

### 5.4.1 Leak test

The plant operator is responsible for performing the leak test and selecting the test method. The leak test must comply with the requirements of the national and international standards that apply at the site of installation.

---

** Tip**

*SAMSON's After-sales Service can support you to plan and perform a leak test for your plant.*

---

1. Slowly open the shut-off valves installed upstream of the regulator.
2. Apply the required test pressure.
3. Check the regulator for leakage to the atmosphere.
4. Depressurize the pipeline section and regulator.
5. Rework any parts that leak and repeat the leak test.

## 5.4.2 Pressure test

---

**i Note**

*The plant operator is responsible for performing the pressure test. SAMSON's After-sales Service can support you to plan and perform a pressure test for your plant.*

---

**! NOTICE**

***Risk of regulator damage due to a sudden pressure increase and resulting high flow velocities.***

→ *Slowly open the shut-off valves.*

---

During the pressure test, make sure the following conditions are met:

- Do not allow the pressure to exceed the 1.5 times the pressure rating of the valve body.
- Make sure that the pressure rises simultaneously upstream and downstream of the regulator to avoid damaging it.

## 6 Start-up

The work described in this section is only to be performed by personnel appropriately qualified to carry out such tasks.

### **⚠ DANGER**

**Risk of personal injury due to process medium escaping.**

→ Do not start up the regulator until all parts have been mounted.

### **⚠ WARNING**

**Risk of burn injuries due to hot or cold components and pipeline.**

Regulator components and the pipeline may become very hot or cold. Risk of burn injuries.

→ Allow components and pipelines to cool down or warm up to the ambient temperature.

→ Wear protective clothing and safety gloves.

### **⚠ WARNING**

**Risk of hearing loss or deafness due to loud noise.**

Noise emission (e.g. cavitation or flashing) may occur during operation caused by the process medium and the operating conditions.

→ Wear hearing protection when working near the valve.

### **⚠ WARNING**

**Risk of personal injury due to pressurized components and process medium being discharged.**

→ Do not loosen the control line while the valve is pressurized.

Before start-up or putting the device back into service, make sure the following conditions are met:

- The regulator is properly installed into the pipeline (see the 'Installation' section).
- The leak and function tests have been completed successfully (see the 'Testing the regulator' section).
- The prevailing conditions in the plant section concerned meet the regulator sizing requirements (see information under 'Intended use' in the 'Safety instructions and measures' section).

### 6.1 Start-up and putting the device back into operation

1. Depending on the field of application, allow the regulator to cool down or warm up to reach ambient temperature before start up.
2. Slowly open the shut-off valves in the pipeline. Slowly opening these valves prevents a sudden surge in pressure and high flow velocities which can damage the valve.
3. Check the regulator to ensure it functions properly.

### 6.2 Starting up the plant

1. Start up the regulator after mounting all parts.
2. Open the shut-off valves slowly preferably starting from the upstream pressure side. Afterwards, open all the valves on the consumer side (downstream of the regulator).
3. Fill the plant **slowly** with the process medium. Avoid pressure surges.
4. Make sure that the pressure rises simultaneously upstream and downstream of the regulator to avoid damaging it.

## 7 Operation

Immediately after completing start-up or placing the regulator back into service (see the 'Start-up' section), the regulator is ready for use.

### **⚠ WARNING**

#### **Risk of burn injuries due to hot or cold components and pipeline.**

*Regulator components and the pipeline may become very hot or cold. Risk of burn injuries.*

- *Allow components and pipelines to cool down or warm up to the ambient temperature.*
- *Wear protective clothing and safety gloves.*

### **⚠ WARNING**

#### **Risk of personal injury due to pressurized components and process medium being discharged.**

- *Do not loosen the control line while the valve is pressurized.*

### **⚠ WARNING**

#### **Risk of hearing loss or deafness due to loud noise.**

*Noise emission (e.g. cavitation or flashing) may occur during operation caused by the process medium and the operating conditions.*

- *Wear hearing protection when working near the valve.*

## 7.1 Adjusting the set point

Every regulator is delivered with the set point listed in Table 7-3 already adjusted.

Turn the set point adjuster (10) using Allen key (width across flats 5) to change the default set point.

5. Undo the lock nut (11).
6. Determine the difference between the fixed set point (Table 7-3) and the required set point. Turn the set point adjuster (10) the required amount of turns as specified in Fig. 7-2.

Based on the default setting, any subsequent change to the set point can be also be made by determining the required number of turns using the specifications listed in Table 7-3.

**Turn the set point adjuster (10) clockwise (↻) to increase the pressure set point.**

**Turn the set point adjuster (10) counter-clockwise (↺) to reduce the pressure set point.**

7. Tighten the lock nut (11).

### **⚠ NOTICE**

#### **Set point adjuster screwed too tight!**

*The regulator is blocked and the medium flow through it is restricted. Pressure regulation is no longer possible.*

*Only screw the set point adjuster up to the point where the spring tension can still be felt.*

## Operation

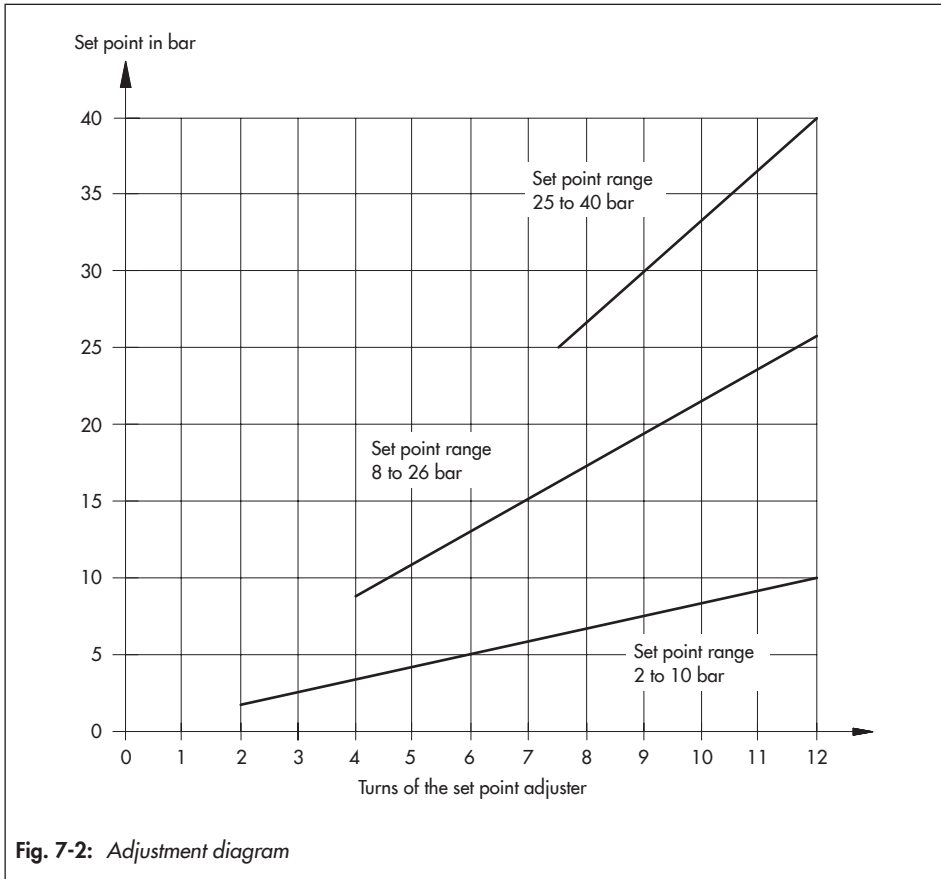

**Table 7-3: Set point adjustment**

Set point range	2 to 10 bar	8 to 26 bar	25 to 40 bar
Adjusted to ...	10 bar	10 bar	25 bar
Set point change per turn	0.8 bar	1.5 bar	3.2 bar



## 8 Malfunctions

### 8.1 Troubleshooting

Malfunction	Possible reasons	Recommended action
Tank pressure drops below the adjusted set point	Operating bellows blocked by the formation of ice	<p>→ Use a heat gun to melt ice.</p> <hr/> <p><b>⚠ DANGER</b></p> <p><b>Depending on the process medium:</b></p> <ul style="list-style-type: none"> <li>– Potentially explosive medium</li> <li>– Potentially explosive atmosphere</li> </ul>
	Pressure build-up vaporizer iced up	<p>→ Reduce consumption until most ice has melted.</p>
	Formation of ice on the pressure build-up vaporizer caused by peak consumption	<p>→ Brush accumulation of ice off the regulator.</p> <hr/> <p><b>⚠ DANGER</b></p> <p><b>Risk of burn injury from touching cold surfaces (see the 'Safety instructions and measures' section).</b></p>
Tank pressure exceeds the adjusted set point	Frozen process medium is blocking the plug.	<p>→ Install a new regulator or isolate the regulator and leave it warm up. Afterwards check whether the frozen medium has sublimated (e.g. dry ice)</p>
	No medium consumption (operational standstill). Incoming heat and medium vaporization.	<p>→ Ensure for continuous medium withdrawal</p>
	Safety function responds after the tank has been filled.	<p>→ Close the shut-off valves (6.1 and 6.2) to isolate the regulator and pressure build-up vaporizer. Let down the tank pressure through medium withdrawal or blow-off. After the pressure set point in the tank is reached, reopen the shut-off valves.</p>

**i Note**

Contact SAMSON's After-sales Service for malfunctions not listed in the table.

## Malfunctions

The malfunctions listed in section 8.1 are caused by mechanical faults and incorrect regulator sizing. In the simplest case, the functioning can be restored following the recommended action. Special tools may be required to rectify the fault.

Exceptional operating and installation conditions may lead to changed situations that may affect the control response and lead to malfunctions. For troubleshooting, the conditions, such as installation, process medium, temperature and pressure conditions, must be taken into account.



**Tip**

*SAMSON's After-sales Service can support you in drawing up an inspection and test plan for your plant.*

---

## 8.2 Emergency action

Plant operators are responsible for emergency action to be taken in the plant.

We recommend removing the regulator from the pipeline before repairing it.

In the event of a regulator malfunction:

1. Close the shut-off valves upstream and downstream of the regulator to stop the process medium from flowing through the regulator.
2. Perform troubleshooting (see section 8.1).
3. Rectify those malfunctions that can be remedied based on the instructions provided here. Contact SAMSON's After-sales Service in all other cases.

### **Putting the regulator back into operation after a malfunction**

See the 'Start-up' section.

## 9 Servicing

The regulator does not require any maintenance. Nevertheless, it is subject to natural wear, particularly at the seat, plug and operating bellows. Depending on the operating conditions, check the regulator at regular intervals to avoid possible malfunctions. Plant operators are responsible for drawing up an inspection and test plan. Details on faults and how to remedy them can be found in the 'Malfunctions' section.

The work described in this section is only to be performed by personnel appropriately qualified to carry out such tasks.

We recommend removing the regulator from the pipeline before performing any maintenance or service work.

---

### **⚠ WARNING**

***Explosion hazard due to the use of oil and grease in oxygen atmospheres!***

*Make sure that the regulator is absolutely clean and free of oil and grease on installing it.*

---

### **⚠ WARNING**

***Risk of burn injuries due to hot or cold components and pipeline.***

*Regulator components and the pipeline may become very hot or cold. Risk of burn injuries.*

- ➔ *Allow components and pipelines to cool down or warm up to the ambient temperature.*
  - ➔ *Wear protective clothing and safety gloves.*
- 

### **⚠ WARNING**

***Risk of personal injury due to residual process medium in the regulator.***

*While working on the regulator, residual process medium can escape and, depending on its properties, may lead to personal injury, e.g. (chemical) burns.*

- ➔ *Wear protective clothing, safety gloves and eye protection.*
-

---

### NOTICE

#### **Risk of regulator damage due to excessively high or low tightening torques.**

Observe the specified torques when tightening regulator components. Excessive tightening torques lead to parts wearing out more quickly. Parts that are too loose may cause leakage.

→ Observe the specified tightening torques (see 'Tightening torques' in Annex).

---

### NOTICE

#### **Risk of regulator damage due to the use of unsuitable tools.**

→ Only use tools approved by SAMSON (see 'Tools' in Annex).

---

### Note

#### **The regulator was checked by SAMSON before it left the factory.**

- Certain test results certified by SAMSON lose their validity when the regulator is opened. Such testing includes seat leakage and leak tests.
  - The product warranty becomes void if service or repair work not described in these instructions is performed without prior agreement by SAMSON's After-sales Service.
  - Only use original spare parts by SAMSON, which comply with the original specifications.
- 

---

### Tip

SAMSON's After-sales Service can support you in drawing up an inspection and test plan for your plant.

---

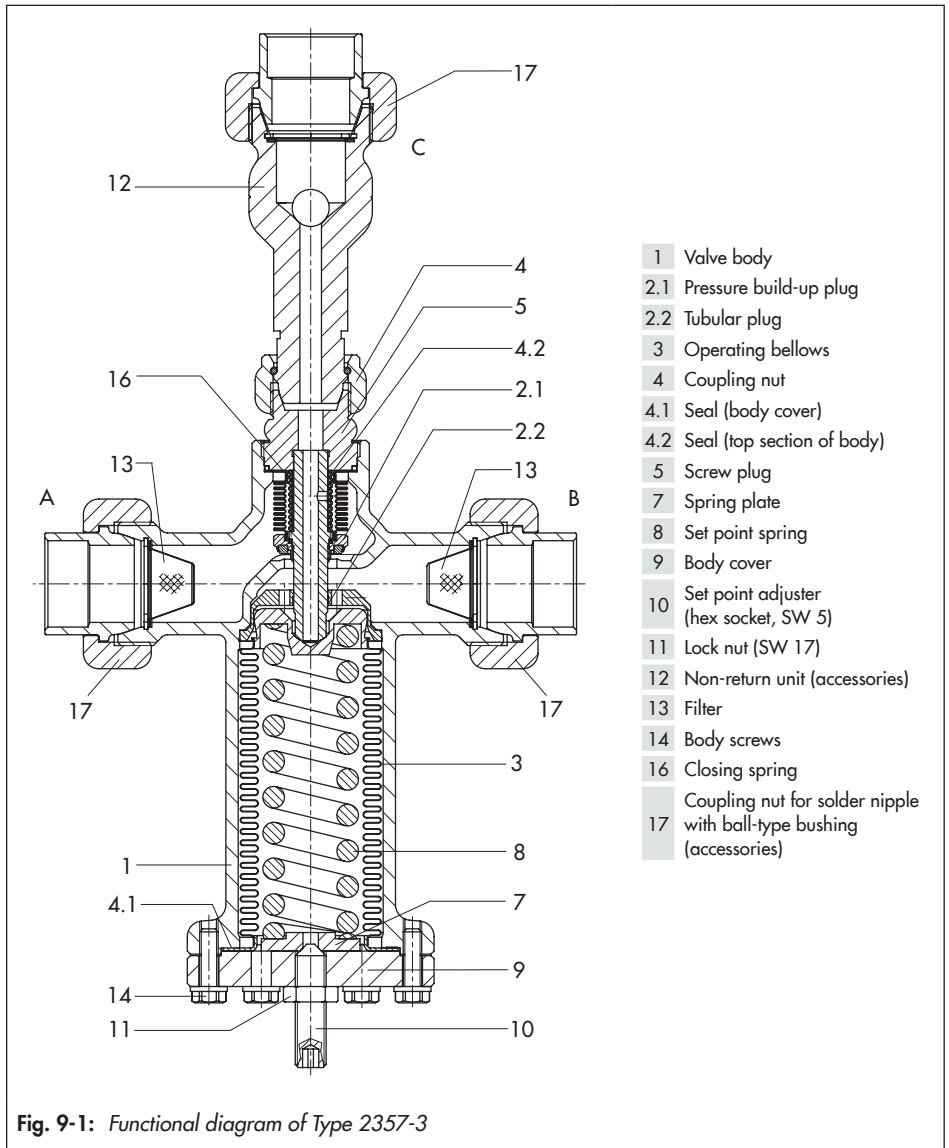

### 9.1 Preparing the valve for service work

1. Lay out the necessary material and tools to have them ready for the service work.
2. Put the regulator out of operation (see the 'Decommissioning' section).



#### Tip

We recommend removing the regulator from the pipeline before performing any service work (see the 'Removing the regulator from the pipeline' section).

The following service work can be performed after preparation is completed:

- Replace the set point spring (see section 9.4)

### 9.2 Installing the regulator after service work

- Put the regulator back into operation (see the 'Start-up' section). Make sure the requirements and conditions for start-up or putting the valve back into operation are met.

### 9.3 Service work

- Before performing any service work, preparations must be made to the regulator (see section 9.1).
- After all service work is completed, check the regulator before putting it back into operation (see the 'Testing the regulator' section).

### 9.4 Replacing the set point spring

- See Fig. 9-1

#### NOTICE

**Risk of regulator damage due to excessively high or low tightening torques.**

Observe the specified torques when tightening regulator components. Excessive tightening torques lead to parts wearing out more quickly. Parts that are too loose may cause leakage.

Observe the specified tightening torques.

#### Note

SAMSON's After-sales Service can support you concerning lubricant, tightening torques and tools approved by SAMSON.

The set point ranges adjusted in the factory can be changed by changing the set point spring (8) and operating bellows (3).  
Data Sheet ► T 2570 · Spare parts and accessories

- While working on the regulator, refer to SAMSON Manual for oxygen ► H 01.

### Removing the set point spring

1. Put the regulator out of operation (see the 'Decommissioning' section).
2. Remove the device from the pipeline
3. Undo the lock nut (11).
4. Completely relieve the tension from the set point spring (8) by turning the set point adjuster (10) counterclockwise (↺).
5. Undo the screws (14).
6. Remove the body cover (9), seal (4.1) and spring plate (7).
7. Take out the set point spring (8) and operating bellows (3).

### Mounting the set point spring

1. Insert new set point spring (8) for the required set point range together with the operating bellows (3) into the valve body (1).
2. Replace the seal (4.1), spring plate (7) and body cover (9).
3. Fasten the housing cover with the screws (14). Observe the specified tightening torques (see 'Tightening torques' in Annex).
4. Turn the set point adjuster (10) clockwise (↻) up to the point where the springs tension can be slightly felt. If necessary, pre-adjust the new set point (see 'Adjusting the set point' in the 'Operation' section).
5. Install the regulator into the pipeline.
6. Put the regulator back into operation (see the 'Start-up' section).

---

**i Note**

*Change the nameplate and material number after changing the set point range.*

---

## **9.5 Ordering spare parts and operating supplies**

Contact your nearest SAMSON subsidiary or SAMSON's After-sales Service for information on spare parts, lubricants and tools.

### **Spare parts**

See Annex for details on spare parts.

### **Lubricant**

Contact SAMSON's After-sales Service for more information on lubricants.

### **Tools**

Contact SAMSON's After-sales Service for more information on tools.



## 10 Decommissioning

The work described in this section is only to be performed by personnel appropriately qualified to carry out such tasks.

### **⚠ DANGER**

**Risk of bursting due to incorrect opening of pressurized equipment or components.**

Regulators and pipelines are pressure equipment that may burst when handled incorrectly. Flying projectile fragments or the release of process medium under pressure can cause serious injury or even death.

**Before working on the regulator:**

- Depressurize all plant sections concerned and the regulator.
- Shut off an external control line.
- Drain the process medium from all the plant sections affected as well as the regulator.

### **⚠ WARNING**

**Risk of burn injuries due to hot or cold components and pipeline.**

Regulator components and the pipeline may become very hot or cold. Risk of burn injuries.

- Allow components and pipelines to cool down or warm up to the ambient temperature.
- Wear protective clothing and safety gloves.

### **⚠ WARNING**

**Risk of personal injury due to pressurized components and process medium being discharged.**

- Do not loosen the external control line while the valve is pressurized.

### **⚠ WARNING**

**Risk of hearing loss or deafness due to loud noise.**

Noise emission (e.g. cavitation or flashing) may occur during operation caused by the process medium and the operating conditions.

- Wear hearing protection when working near the regulator.

### **⚠ WARNING**

**Risk of personal injury due to residual process medium in the regulator.**

While working on the regulator, residual process medium can escape and, depending on its properties, may lead to personal injury, e.g. (chemical) burns.

- Wear protective clothing, safety gloves and eye protection.

## Decommissioning

To decommission the regulator for service work or disassembly, proceed as follows:

1. Close the shut-off valve (6.1) on the upstream side of the regulator.
2. Close the shut-off valve (6.2) on the downstream side of the regulator.
3. Completely drain the pipelines and regulator.
4. Depressurize the plant.
5. Allow the pipeline and device to heat up.
6. Detach the pipe fittings.
7. Remove the regulator from the pipeline.

## 11 Removal

The work described in this section is only to be performed by personnel appropriately qualified to carry out such tasks.

### **⚠ WARNING**

#### ***Risk of burn injuries due to hot or cold components and pipeline.***

*Regulator components and the pipeline may become very hot or cold. Risk of burn injuries.*

- *Allow components and pipelines to cool down or warm up to the ambient temperature.*
- *Wear protective clothing and safety gloves.*

### **⚠ WARNING**

#### ***Risk of personal injury due to residual process medium in the regulator.***

*While working on the regulator, residual process medium can escape and, depending on its properties, may lead to personal injury, e.g. (chemical) burns.*

- *Wear protective clothing, safety gloves and eye protection.*

Before removing the valve, make sure the following conditions are met:

- The regulator is put out of operation (see the 'Decommissioning' section).

### 11.1 Removing the regulator from the pipeline

1. Support the regulator to hold it in place when separated from the pipeline (see the 'Shipment and on-site transport' section).
2. Undo the pipe connections.
3. Remove the regulator from the pipeline (see the 'Shipment and on-site transport' section).

### 11.2 Removing the actuator from the valve

See the 'Servicing' section.



## 12 Repairs

If the regulator does not function properly according to how it was originally sized or does not function at all, it is defective and must be repaired or exchanged.

---

**! NOTICE**

***Risk of regulator damage due to incorrect service or repair work.***

- *Do not perform any repair work on your own.*
  - *Contact SAMSON's After-sales Service for service and repair work.*
- 

### 12.1 Returning devices to SAMSON

Defective devices can be returned to SAMSON for repair. Proceed as follows to return devices to SAMSON:

1. Put the regulator out of operation (see the 'Decommissioning' section).
2. Decontaminate the valve. Remove any residual process medium.
3. Fill in the Declaration on Contamination. The declaration form can be downloaded from our website at
  - ▶ [www.samsongroup.com](http://www.samsongroup.com) > SERVICE & SUPPORT > After-sales Service.
4. Continue as described on our website at
  - ▶ [www.samsongroup.com](http://www.samsongroup.com) > SERVICE & SUPPORT > After Sales Service > Returning goods.



## 13 Disposal

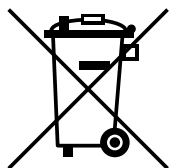

SAMSON is a producer registered at the following European institution ► <https://www.ewrn.org/national-registers/national-registers>.  
WEEE reg. no.:  
DE 62194439/FR 025665

- Observe local, national and international refuse regulations.
- Do not dispose of components, lubricants and hazardous substances together with your other household waste.

---

### **i** Note

*We can provide you with a recycling passport according to PAS 1049 on request. Simply e-mail us at [offersaleservice@samsongroup.com](mailto:offersaleservice@samsongroup.com) giving details of your company address.*

---

### Tip

*On request, we can appoint a service provider to dismantle and recycle the product as part of a distributor take-back scheme.*

---





## 14 Certificates

The EU declarations of conformity are included on the next pages:

- EU declaration of conformity in compliance with Pressure Equipment Directive 2014/68/EU on page 14-2.
- EU declaration of conformity in compliance with Machinery Directive for Type 2357-3 Regulator on page 14-3.
- EU-type examination according to Directive 2014/68/EC, see page 14-4.
- Additional manufacturer's declarations, see page 14-5 ff.

EU DECLARATION OF CONFORMITY  
TRANSLATION



**Module D, No. / N° CE-0062-PED-D-SAM 001-20-DEU**

For the following products, SAMSON hereby declares under its sole responsibility:

**Pressure Regulator PR 2357-1, -11, -2-, -21, -3**

the conformity with the following requirement.

Directive of the European Parliament and of the Council on the harmonization of the laws of the Member States relating to the making available on the market of pressure equipment. 2014/68/EU of 15 May 2014

EC Type Examination Certificate Module B Certificate no. 01 202 931-B-10-16

Conformity assessment procedure applied Module D Certificate no. CE-0062-PED-D-SAM-001-20-DEU

The design is based on the procedures specified in the following standards:  
DIN EN 12516-3 or ASME B16.24

The manufacturer's quality management system is monitored by the following notified body:

Bureau Veritas Services SAS, 8 Cours du Triangle, 92800 PUTEAUX – LA DEFENSE, France  
Manufacturer: SAMSON AG, Weismüllerstraße 3, 60314 Frankfurt am Main, Germany

Frankfurt am Main, 11. May 2020

  
Thorsten Muth  
Senior Director  
Sales and After-sales

  
i. V. P. Scheermesser  
Peter Scheermesser  
Head of Central Department  
Product maintenance, contract development and ETO  
for valves and actuators

Revision 04

Classification: Public: SAMSON AKTIENGESELLSCHAFT · Weismuellerstrasse 3 · 60314 Frankfurt am Main, Germany Seite 1 von 1

EU DECLARATION OF CONFORMITY  
TRANSLATION



**Declaration of Conformity of Final Machinery**

in accordance with Annex II, section 1.A. of the Directive 2006/42/EC

For the following products:

**Type 2357-3 Pressure Build-up Regulator**

We hereby declare that the machinery mentioned above complies with all applicable requirements stipulated in Machinery Directive 2006/42/EC.

For product descriptions refer to:

- Type 2357-3 Pressure Build-up Regulator: Mounting and Operating Instructions EB 2559

Referenced technical standards and/or specifications:

- VCI, VDMA, VGB: "Leitfaden Maschinenrichtlinie (2006/42/EG) – Bedeutung für Armaturen, Mai 2018" [German only]
- VCI, VDMA, VGB: "Zusatzdokument zum Leitfaden Maschinenrichtlinie (2006/42/EG) – Bedeutung für Armaturen vom Mai 2018" [German only], based on DIN EN ISO 12100:2011-03

Comment:

Information on residual risks of the machinery can be found in the mounting and operating instructions as well as in the referenced documents listed in the mounting and operating instructions.

Persons authorized to compile the technical file:

SAMSON AG, Weismüllerstraße 3, 60314 Frankfurt am Main, Germany  
Frankfurt am Main, 22 August 2022

Norbert Tollas  
Senior Vice President  
Global Operations

Peter Scheermesser  
Director  
Product Maintenance and Engineered Products

Revision no. 00

Classification: Public · SAMSON AKTIENGESELLSCHAFT · Weismüllerstraße 3 · 60314 Frankfurt am Main, Germany

Page 1 of 1

# Zertifikat

## EU-Baumusterprüfung (Baumuster) nach Richtlinie 2014/68/EU

Zertifikat-Nr.: 01 202 969/B-22-0002

Name und Anschrift des  
Herstellers: Samson AG  
Weismüllerstraße 3  
60315 Frankfurt

Hiermit wird bescheinigt, dass das unten genannte  
EU-Baumuster die Anforderungen der Richtlinie 2014/68/EU  
erfüllt.

Geprüft nach Richtlinie **Modul B**  
2014/68/EU: **EU-Baumusterprüfung (Baumuster)**

Prüfbericht-Nr.: 968/FSP 2402.01/22

Beschreibung des Baumusters: Sicherheitsdruckregler ohne Hilfenenergie als Ausrüstungsteil mit  
Sicherheitsfunktion

Typ: 2357-1, 2357-2, 2357-3, 2357-11, 2357-21

Fertigungsstätte/Lieferer: Samson AG  
Weismüllerstraße 3  
60315 Frankfurt

Gültig bis: 03/32  
Dieses Zertifikat verliert seine Gültigkeit, wenn das Produkt in  
irgendeiner Weise geändert oder modifiziert wird.

Das CE-Zeichen darf erst am Produkt angebracht und die Konformitätserklärung erst ausgestellt  
werden, wenn ein korrespondierendes Konformitätsbewertungsverfahren der Richtlinie 2014/68/EU  
bezogen auf die Produktion/das Produkt vollständig erfüllt ist.



Köln, 18.03.2022

  
Wolf Rückwart

TÜV Rheinland Industrie Service GmbH  
Notifizierte Stelle für Druckgeräte, Kennnummer 0035  
Am Grauen Stein, D-51105 Köln, DEUTSCHLAND

© TÜV, TÜV und TÜV sind eingetragene Marken. Eine Nutzung und Vervielfältigung bedarf der vorherigen Zustimmung.

# MANUFACTURER'S DECLARATION



**Translation of original document**

For the following products

**Type 2357 Pressure Regulator**

**Versions for oxygen service according to SAMSON company standard WN 1.34-2, sheets 1 and 1.1 (Q-7004)**

We hereby confirm that all oxygen-wetted parts of the above mentioned regulators are cleaned, tested and assembled according to our qualified cleaning procedure. Cleaned parts are assembled in accordance with our assembly procedure to avoid any recontamination.

We also confirm that all non-metallic parts coming into contact with oxygen are compatible with oxygen for the specified operating conditions.

Max. operating temperature: 60 °C

Max. operating pressure: 40 bar(g)

**List of non-metallic materials and lubricants with trade name and manufacturer information:**

Part	Trade name	Manufacturer
Gasket	Dyneon TF 4303 (PTFE)	IDT Industrie- und Dichtungstechnik GmbH
Soft seal	Dyneon TF 4303 (PTFE)	IDT Industrie- und Dichtungstechnik GmbH
Ball	Dyneon TF 4303 (PTFE)	IDT Industrie- und Dichtungstechnik GmbH
Lubricants	Gleitmo 595	Fuchs Lubritech GmbH, Kaiserslautern, Germany

**SAMSON AKTIENGESELLSCHAFT**

  
 i.A. Norbert Tollas  
 Produktionsleiter  
 Global Produktion & Innovation

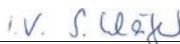
  
 i.V. Silke Bianca Schäfer  
 Zentralabteilungsleiterin  
 Integriertes Management System

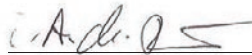
  
 i.A. Martin Brüssau  
 Zentralabteilungsleiter  
 Technischer Vertrieb

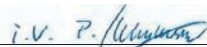
  
 i.V. Peter Scheermesser  
 Zentralabteilungsleiter  
 Produktpflege, Auftragsabwicklung und ETO  
 für Ventile und Antriebe

**SAMSON AG**  
MESS- UND REGELTECHNIK



## Manufacturer's Declaration

For the following products:

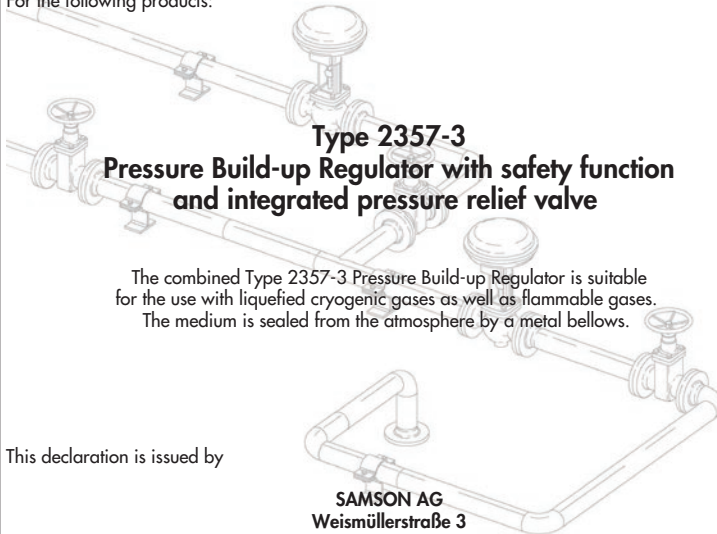

**Type 2357-3**  
**Pressure Build-up Regulator with safety function**  
**and integrated pressure relief valve**

The combined Type 2357-3 Pressure Build-up Regulator is suitable for the use with liquefied cryogenic gases as well as flammable gases. The medium is sealed from the atmosphere by a metal bellows.

This declaration is issued by

**SAMSON AG**  
**Weismüllerstraße 3**  
**60314 Frankfurt am Main**  
**Germany**

Frankfurt, 28 August 2007

Uwe Vogel  
Head of Central Department  
Technical Sales

Rudolf Lässler  
Head of Central Department  
Self-operated Regulator Development

SAMSON AG Weismüllerstraße 3 Phone: +49 69 4009-0 Chairman of the Executive Board: Gernot Frank (CEO), Registered in  
Postfach 10 19 01 60314 Frankfurt/M., Germany Fax: +49 69 4009-1507 Supervisory Board: Hans-Erich Grimm, Prof. Dr. Heinfried Hoffmann, Frankfurt/Main  
60019 Frankfurt/M., Germany http://www.samson.de E-mail: samson@samson.de Dr. Nikolaus Hensel Dr. Josef Tonus, Ludwig Wiesner under No. HRB 7131

**Manufacturer's Declaration**  
**V4/HE-1087-0**

Changed on:  
By:

2007-08-28  
V41/Kls/V44/Rch

## 15 Annex

### 15.1 Tightening torques

**Table 15-1:** *Tightening torque*

Position	Part	Width across flats	Tightening torque in Nm
4	Coupling nut	SW 32	60
5	Screw plug	SW 26	70
14	Screws	SW 10	7
17	Coupling nut for solder nipple with ball-type bushing (accessories)	SW 49	100

## 15.2 Lubricant

SAMSON's After-sales Service can support you concerning lubricants and sealants approved by SAMSON.

## 15.3 Tools

SAMSON's After-sales Service can support you concerning tools approved by SAMSON.

## 15.4 Spare parts

SAMSON's After-sales Service can support you concerning spare parts approved by SAMSON.

---

**i Note**

*All spare parts and accessories are listed in the Data Sheet ► T 2570.*

---

## 15.5 Accessories

SAMSON's After-sales Service can support you concerning accessories approved by SAMSON.

---

**i Note**

*All spare parts and accessories are listed in the Data Sheet ► T 2570.*

---

## 15.6 After-sales service

Contact SAMSON's After-sales Service for support concerning service or repair work or when malfunctions or defects arise.

### E-mail address

You can reach our after-sales service at [aftersalesservice@samsongroup.com](mailto:aftersalesservice@samsongroup.com).

### Addresses of SAMSON AG and its subsidiaries

The addresses of SAMSON, its subsidiaries, representatives and service facilities worldwide can be found on our website (► [www.samsongroup.com](http://www.samsongroup.com)) or in all SAMSON product catalogs.

### Required specifications

Please submit the following details:

- Device type and valve size
- Model number and configuration ID
- Upstream and downstream pressure
- Temperature and process medium
- Min. and max. flow rate
- Is a strainer installed?
- Installation drawing showing the exact location of the regulator and all the additionally installed components (shut-off valves, pressure gauge etc.)









**EB 2559 EN**



SAMSON AKTIENGESELLSCHAFT  
Weismüllerstraße 3 · 60314 Frankfurt am Main, Germany  
Phone: +49 69 4009-0 · Fax: +49 69 4009-1507  
samson@samsongroup.com · www.samsongroup.com