

MOUNTING AND OPERATING INSTRUCTIONS

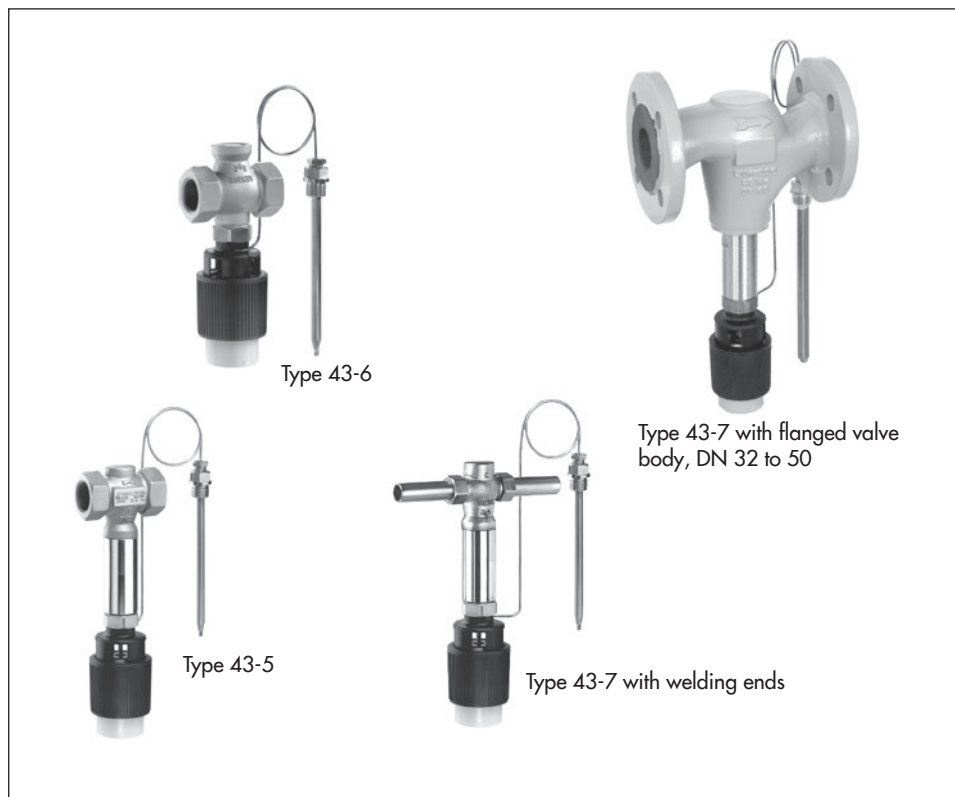

EB 2172 EN

Translation of original instructions



Type 43-5 · Type 43-7 · Type 43-6 Series 43 Temperature Regulators

Note on these mounting and operating instructions

These mounting and operating instructions assist you in mounting and operating the device safely. The instructions are binding for handling SAMSON devices.

- For the safe and proper use of these instructions, read them carefully and keep them for later reference.
- If you have any questions about these instructions, contact SAMSON's After-sales Service Department (aftersaleservice@samson.de).



The mounting and operating instructions for the devices are included in the scope of delivery. The latest documentation is available on our website at www.samson.de > **Service & Support** > **Downloads** > **Documentation**.

Definition of signal words

DANGER

Hazardous situations which, if not avoided, will result in death or serious injury

WARNING

Hazardous situations which, if not avoided, could result in death or serious injury

NOTICE

Property damage message or malfunction

Note

Additional information

Tip

Recommended action

1	General safety instructions	4
2	Process medium and scope of application	5
2.1	Transportation and storage	5
3	Design and principle of operation	6
3.1	Version with safety thermostat	6
3.2	Version with double adapter	6
4	Installation	8
4.1	Temperature sensor	8
4.1.1	Capillary tube	9
4.2	Strainers	9
4.3	Additional components	10
5	Operation	10
5.1	Start-up.....	10
5.2	Adjusting the set point	10
6	Maintenance – Replacing parts	12
6.1	Cleaning or replacing the plug.....	12
7	After-sales service	13
8	Dimensions	16
8.1	Dimension tables.....	17
9	Technical data	18



1 General safety instructions

- The device must be mounted, started up or serviced by fully trained and qualified personnel only; the accepted industry codes and practices are to be observed. Make sure employees or third persons are not exposed to any danger.
- All safety instructions and warnings given in these mounting and operating instructions, particularly those concerning installation, start-up, and maintenance, must be strictly observed.
- According to these mounting and operating instructions, trained personnel refers to individuals who are able to judge the work they are assigned to and recognize possible dangers due to their specialized training, their knowledge and experience as well as their knowledge of the applicable standards.
- The devices comply with the requirements of the European Pressure Equipment Directive 2014/68/EU. Devices with a CE marking have a declaration of conformity, which includes information about the applied conformity assessment procedure. This declaration of conformity can be provided on request. This declaration of conformity can be provided on request.
- To ensure appropriate use, only use the device in applications where the operating pressure and temperatures do not exceed the specifications used for sizing the device at the ordering stage.
- The manufacturer does not assume any responsibility for damage caused by external forces or any other external factors.
- Any hazards that could be caused in the temperature regulator by the process medium, operating pressure or by moving parts are to be prevented by taking appropriate precautions.
- Proper transport, storage, installation, operation and maintenance are assumed.



Testing according to DIN EN

The Type 43-5, Type 43-6 and Type 43-7 Temperature Regulators are tested by the German Technical Inspectorate (TÜV) according to DIN EN 14597. The register number is available on request.

2 Process medium and scope of application

Temperature control in heat generators or heat exchangers by closing and opening a valve (Series 43)

For set points from **0** to **150 °C** · Valves **G ½** to **1** and **DN 15** to **150** · **PN 25** · Max. **200 °C**

Liquids and steam up to 200 °C and non-flammable gases up to 80 °C · For plants to be heated or cooled.

2.1 Transportation and storage

The devices must be carefully handled, transported and stored. Protect the devices against adverse influences, such as dirt, moisture or temperature outside the maximum ambient temperature range from -20 to +80 °C.

3 Design and principle of operation

See Fig. 1.

The regulators consist of a Type 2436 Globe Valve (Type 43-6), Type 2435 Globe Valve (Type 43-5) or Type 2437 (Type 43-7) and a Type 2430 Control Thermostat with set point adjuster, capillary tube and a temperature sensor working according to the adsorption principle.

i Note

Details on the Type 2430 Thermostat with a temperature sensor working according to the vapor pressure principle ► EB 2430-3.

The bodies are available made of red brass, spheroidal graphite iron or stainless steel.

See Data Sheet ► T 2176 for versions with double adapter or manual adjuster for the attachment of additional control thermostats

The Type 2430 Thermostat is attached to the valve body using the coupling nut.

The temperature regulators work according to the adsorption principle. The temperature of the measured medium creates a pressure in the temperature sensor which is proportional to the measured temperature. This pressure is transferred through the capillary tube (10) to the operating element (13) and converted into a positioning force. This force causes the pin of the operating element (12) to move the plug stem (4) with the valve plug. By turning the set point adjuster (8), the point of response is changed over the valve spring (5).

The valves are balanced by a balancing bellows (3.1). The balancing bellows counterbalances any changes in pressure upstream of the valve since the upstream pressure also acts on the inside of the bellows through a hole in the valve plug (3).

The Type 43-5 and Type 43-7 Regulators are suitable for plants to be heated. The valves close when the temperature rises.

The Type 43-6 Regulator has a valve which opens as the temperature rises. This regulator is therefore suitable for plants to be cooled.

3.1 Version with safety thermostat

When a Type 2439/2403 Safety Thermostat is attached to the valve or the regulator, this combination functions as a safety temperature limiter (STL) or a temperature regulator with safety temperature limiter (TR/STL).

Details in mounting and operating instructions ► EB 2185.

3.2 Version with double adapter

The temperature regulator can be equipped with a double adapter to connect an additional thermostat to control a further control variable.

Details in mounting and operating instructions ► EB 2176.

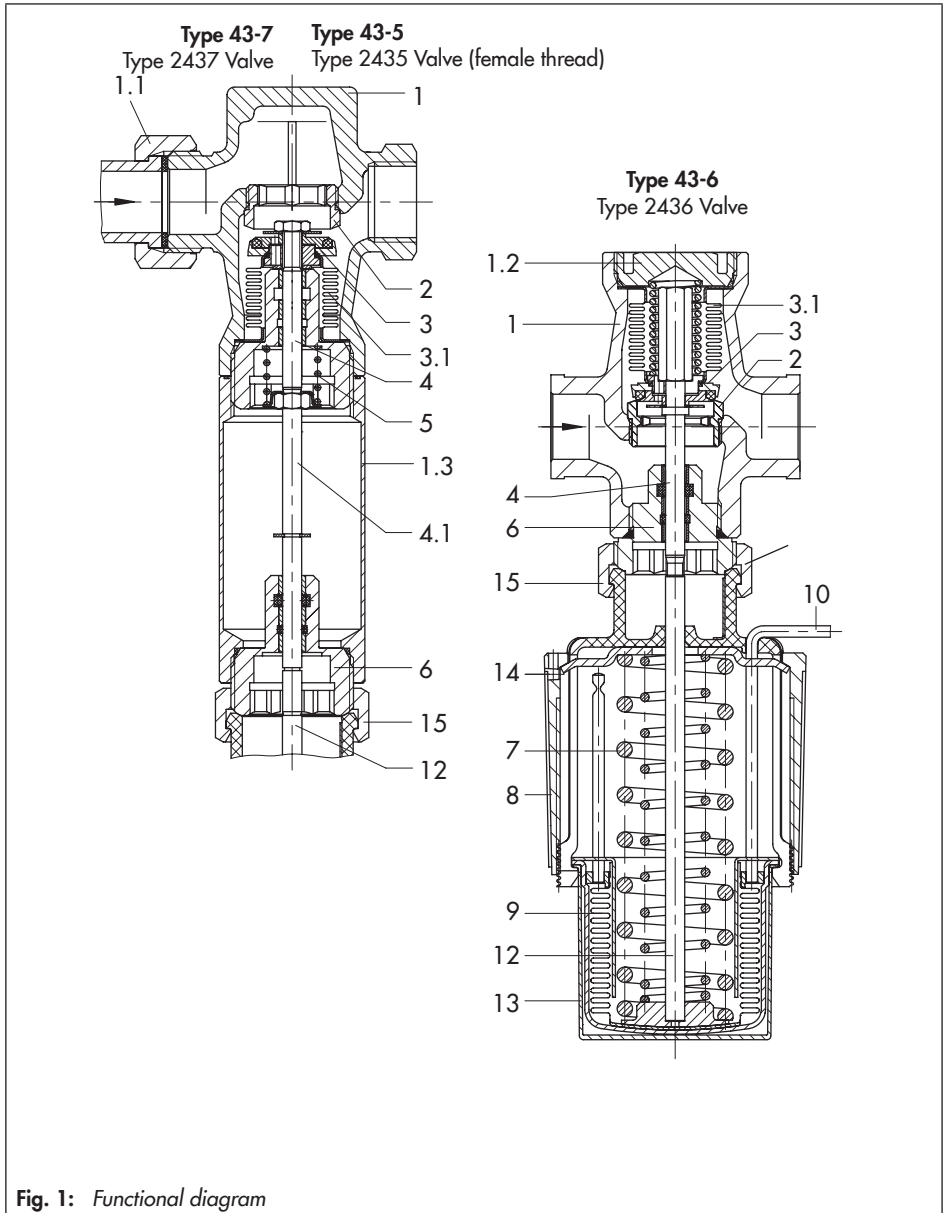

4 Installation

Choose a place of installation that allows you to freely access the regulator even after the entire plant has been completed. Make sure that the permissible ambient temperature does not fall below $-20\text{ }^{\circ}\text{C}$ or exceed $+80\text{ }^{\circ}\text{C}$.

Flush the pipeline thoroughly before installing the regulator to ensure that any sealing parts, weld spatter and other impurities carried along by the process medium do not impair the proper functioning of the valve, above all the tight shut-off.

i Note

Type 43-5/Type 43-7: *If the valve is to be insulated, two thirds of the insulating pipe (1.3) must remain uninsulated.*

- Install the valve free of stress and with the least amount of vibrations as possible.
- The flow of direction must correspond with the direction indicated by the arrow on the valve body.
- The control thermostat must be suspended to hang downward. Other mounting positions are possible for Type 43-6 up to $110\text{ }^{\circ}\text{C}$.

i NOTICE

Malfunction and damage due to adverse weather conditions (temperature, humidity). Do not install the temperature regulator outdoors or in rooms prone to frost. If such a location cannot be avoided, protect the regulator against freezing up if the process medi-

um flowing through the valve can freeze up. Either heat the regulator or remove it from the plant and completely drain the residual medium.

4.1 Temperature sensor

i NOTICE

Galvanic corrosion due to incorrectly selected materials of the mounting parts. On installing the sensor or thermowell, only combine the same kind of materials (e.g. stainless steel with stainless steel or copper together with other copper materials).

The temperature sensor may be installed in any position even when a thermowell is used. However, make sure its entire length is immersed in the process medium to be controlled. It must be installed in a location where overheating or considerable idling times cannot occur.

i Note

If the sensor is to be used with a thermowell, only use original SAMSON thermowells.

Weld a welding socket with G $\frac{1}{2}$ or G $\frac{3}{4}$ female thread (to match the screw gland) at the place of installation.

➔ Seal the screw gland of the sensor.

Installation with thermowell

When a thermowell is used, a welding socket with G 1 female thread must be used.

➔ Seal the thermowell into the welding

socket. Insert the sensor and tighten it with the clamping screw.

i Note

For temperature regulators with safety temperature limiter (TR/STL), install the sensor of the limiter near the sensor of the regulator.

4.1.1 Capillary tube

Carefully run the capillary tube without bending or twisting it. Avoid locations with considerable ambient temperature fluctuations along the entire length of the tube.

i Note

Do not damage or shorten the capillary tube. Roll up any capillary tube that is not used. The smallest permissible bending radius is 50 mm.

4.2 Strainers

Install the strainer upstream of the temperature regulator.

- The flow of direction must correspond with the direction indicated by the arrow on the body.
- The filter element must be installed to hang downward.

Tip

Remember to leave enough space to remove the filter element for cleaning.

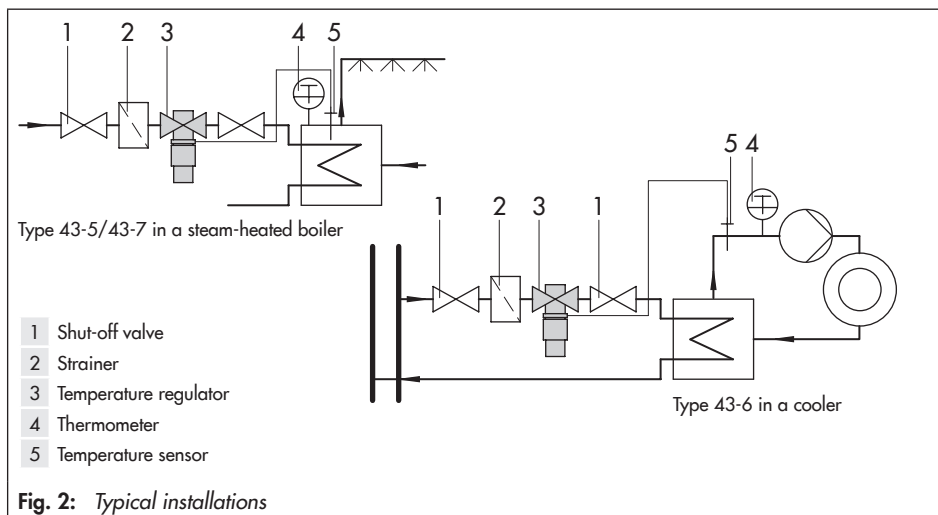

4.3 Additional components

We recommend installing a hand-operated shut-off valve upstream of the strainer and downstream of the regulator to be able to shut down the plant for cleaning and maintenance and when the plant is not used for longer periods of time.

To check the adjusted set point, we recommend installing a thermometer immersed in the medium to be controlled near the sensor.

5 Operation

See Fig. 1.

5.1 Start-up

- ➔ Put the temperature regulator into operation after mounting the valve and control thermostat.
- ➔ Fill the plant slowly with the process medium (without pressure surges).
Slowly open the hand-operated shut-off valve downstream of the valve and then the shut-off valve upstream of the valve.
- ➔ Check the adjusted temperature set point at the thermometer installed near the temperature sensor.

5.2 Adjusting the set point

To adjust the set point, turn the black plastic adjuster while watching the reference thermometer.

- Turn clockwise (↻) to reduce the temperature
- Turn counterclockwise (↺) to increase the temperature

The adjustment diagrams (see Fig. 3) can be used as a guide to find the first approximate value.



Tip

Higher set point temperatures can be adjusted in increments as required. However, to lower the set point temperature, proceed in steps of 10 to 20 °C. When doing so, wait for the process medium to cool down before continuing. Watch the thermometer.

Table 1: Set point ranges

Set point range in °C	Set point change per turn	Sensor Ø
0 to 35 °C	2.5 °C	9.5 mm
	2 °C	16 mm
25 to 70 °C	3 °C	9.5 mm
	2 °C	16 mm
40 to 100 °C	4 °C	9.5 mm
	3 °C	16 mm
50 to 120 °C	4 °C	9.5 mm
	4.5 °C	16 mm
70 to 150 °C	4.5 °C	9.5 mm
	5 °C	16 mm

Type 43-5/43-7

Set point ranges for DN 15 to 25
with sensor \varnothing 9.5 mm

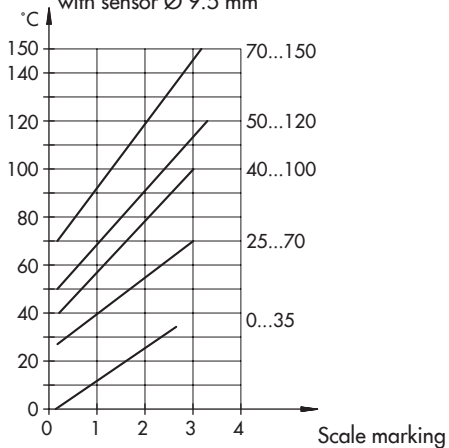

Set point ranges for DN 32 to 50
with sensor \varnothing 16 mm

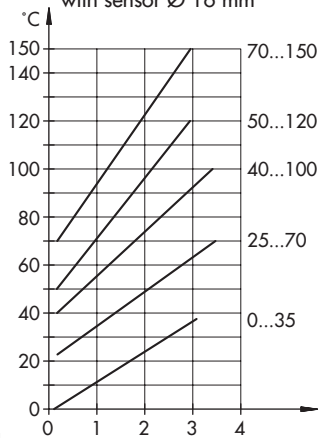

Type 43-6

Set point ranges for DN 15 to 25
with sensor \varnothing 9.5 mm

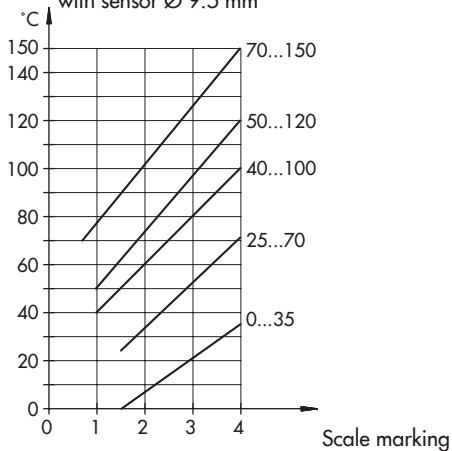

Set point ranges for DN 32 to 50
with sensor \varnothing 16 mm

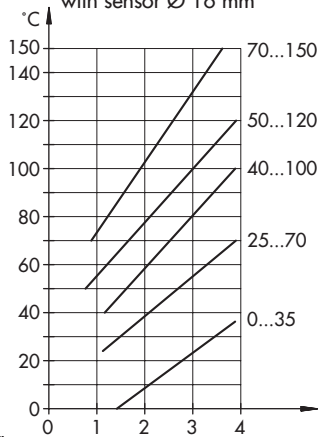

Fig. 3: Adjustment diagrams

6 Maintenance – Replacing parts

See Fig. 1.

The temperature regulators do not require any maintenance. Nevertheless, they are subject to natural wear, particularly at the seat and plug.

Depending on the operating conditions, check the regulator at regular intervals to avoid possible malfunctions.

If the temperature exceeds the value adjusted at the temperature sensor, possible causes for this are:

- The thermostat is defective due to excessive temperatures.
- Valve seat and plug are contaminated with dirt.
- Seat and plug leak due to natural wear.

Before performing any work on the temperature regulator, we recommend removing the valve from the pipeline.

WARNING

Risk of injury due to process medium escaping possibly under pressure.

Depressurize the relevant section of the pipeline and, if necessary, drain it as well. When used at high temperatures, allow the plant section to cool down to ambient temperature.

Exceptional operating and installation conditions can lead to changed situations that may affect the control response and lead to malfunctions. In such cases, check the installation conditions, process medium, temperature and pressure conditions.

For initial evaluation of faults and how to remedy them, refer to Table 2 on page 14.

The table is not intended to be exhaustive as there are diverse reasons for malfunctions.

6.1 Cleaning or replacing the plug

To change the plug (3), a special plug wrench is needed:

For DN 15 to 25	Order no.: 1280-3001
-----------------	----------------------

For DN 32 to 50	Order no.: 1280-3007
-----------------	----------------------

To change the seat (2), a special seat wrench is needed:

For DN 15 to 25	Order no.: 1280-3012
-----------------	----------------------

For DN 32 to 50	Order no.: 1280-3013
-----------------	----------------------

The special tools are available from SAMSON.

How to proceed:

Types 43-5 and 43-7

1. Unscrew the coupling nut (15) and remove the control thermostat.
2. Unscrew the guide nipple (6) and insulating pipe (1.3) from the valve body.

3. Use the plug wrench to pull out the entire plug section.
4. Thoroughly clean the seat (2) and plug (3). If the seat is damaged, it must be replaced using the seat wrench. If the plug is damaged, the entire plug section as well as the seal in the body must be renewed.

Type 43-6

1. Unscrew stopper (1.2) and pull out the entire plug section.
2. Thoroughly clean the seat and plug. If the seat is damaged, it must be replaced using the seat wrench.

If the plug is damaged, the entire plug section as well as the seal in the body must be renewed.

To reassemble, proceed in reverse order. If necessary, insert a new seal for the plug section into the body. Screw in the plug section (tightening torque approx. 80 Nm).

Connect the thermostat and valve using the coupling nut (1.5). Tightening torque approx. 20 Nm.

worldwide can be found on the SAMSON website (► www.samson.de), in all SAMSON product catalogs or on the back of these Mounting and Operating Instructions.

To assist diagnosis, specify the following details:

- Type and valve size, Type ... Thermostat
- Model number with index
- Upstream and downstream pressure
- Temperature and process medium
- Min. and max. flow rate
- Is a strainer installed?
- Installation drawing showing the exact location of the regulator and all the additionally installed components (shut-off valves, thermometer etc.).

7 After-sales service

If malfunctions or defects occur, contact the SAMSON's After-sales Service department for support.

Please send your inquiries to: aftersaleservice@samson.de

The addresses of SAMSON AG, its subsidiaries, representatives and service facilities

Table 2: Troubleshooting

Type 43-5 and Type 43-7

Possible reasons	Recommended action
Temperature at the sensor exceeds the set point	
Leak at seat and plug	Remove valve from the pipeline and clean seat and plug. Renew plug, if necessary. If this is not possible, return regulator to SAMSON for repair.
Size (DN or G) of the valve is much too large for the control task.	Recalculate K_{VS} and select a smaller valve.
Sensor installed in the wrong location.	The entire length of the temperature sensor must be immersed in the process medium and where idle times or heat buildup cannot occur. Change mounting position accordingly.
A safety device (e.g. STL or STM) has been triggered.	Check plant. Unlock safety device.
Thermostat defective	Replace thermostat (read specifications on the nameplate).
Temperature at the sensor does not reach the set point	
Size (DN or G) of the valve is much too small for the control task.	Recalculate K_{VS} and select a larger valve.
Insufficient heating energy available	Draw up an energy balance.
Strainer blocked	Drain and clean filter of the strainer.
The valve is not installed in the direction indicated by the arrow.	Install the valve in such a way that the flow of direction corresponds with the direction indicated by the arrow on the valve body.
Control loop hunts - Very long dead time/sluggish control response	
Size (DN or G) of the valve is much too large for the control task.	Recalculate K_{VS} and select a smaller valve.
Time constant is too large for the control loop.	Fill the thermowell with thermal paste, remove thermowell or use sensor with smaller time constant.
Sensor installed in the wrong location.	The temperature sensor may be installed too far from the area where the temperature to be controlled arises. Locate the sensor closer to heat exchanger.
The valve is not installed in the direction indicated by the arrow.	Install the valve in such a way that the flow of direction corresponds with the direction indicated by the arrow on the valve body.

Type 43-6

Possible reasons	Recommended action
Temperature at the sensor exceeds the set point	
Size (DN or G) of the valve is much too small for the control task.	Recalculate K_{VS} and select a larger valve.
Thermostat defective	Replace thermostat (read specifications on the nameplate).
Insufficient cooling energy available	Draw up an energy balance.
Strainer blocked	Drain and clean filter of the strainer.
Sensor installed in the wrong location.	The entire length of the temperature sensor must be immersed in the process medium and where idle times or heat buildup cannot occur. Change mounting position accordingly.
Temperature at the sensor does not reach the set point	
Leak at seat and plug	Remove valve from the pipeline and clean seat and plug. Renew plug, if necessary. If this is not possible, return regulator to SAMSON for repair.
Valve too large for control task	Recalculate K_{VS} and select a smaller valve.
A safety device (e.g. STL, STM etc.) has been triggered.	Check plant. Unlock safety device.
Control loop hunts · Very long dead time/sluggish control response	
Size (DN or G) of the valve is much too large for the control task.	Recalculate K_{VS} and select a smaller valve.
Time constant is too large for the control loop.	Fill the thermowell with thermal paste, remove thermowell or use sensor with smaller time constant.
The valve is not installed in the direction indicated by the arrow.	Install the valve in such a way that the flow of direction corresponds with the direction indicated by the arrow on the valve body.
Sensor installed in the wrong location.	The temperature sensor may be installed too far from the area where the temperature to be controlled arises. Locate the sensor closer to heat exchanger.

8 Dimensions

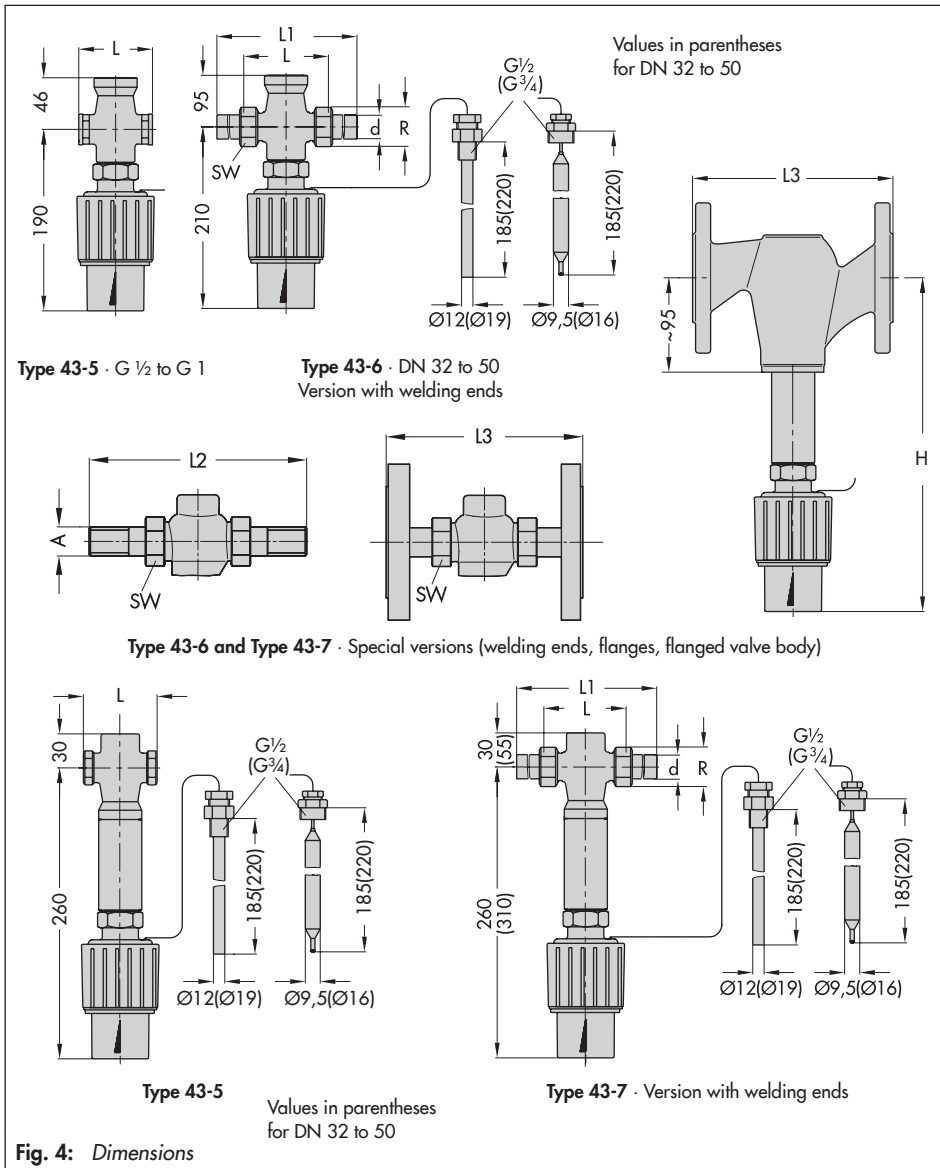

8.1 Dimension tables

Dimensions in mm and weights in kg

Table 3: Type 43-6 (DN 32 to 50) and Type 43-7 (DN 15 to 50)

Valve size	DN 15	DN 20	DN 25	DN 32	DN 40	DN 50
Pipe Ø d	21.3	26.8	32.7	42	48	60
Connection R	G ¾	G 1	G 1¼	G 1¾	G 2	G 2½
AF	30	36	46	59	65	82
Length L	65	70	75	100	110	130
L1 with welding ends	210	234	244	268	294	330
Weight ¹⁾ in kg (approx.)	2	2.3	2.8	4.7	5.1	7.5
Special versions						
With threaded ends (male thread)						
Length L2	129	144	159	180	196	228
Male thread A	G ½	G ¾	G 1	G 1¼	G 1½	G 2
Weight ¹⁾ in kg (approx.)	2	2.3	2.8	4.7	5.1	7.5
With flanges ²⁾ (PN 16/25)						
Length L3	130	150	160	180	200	230
Weight ¹⁾ in kg (approx.)	3.1	3.9	4.6	7.6	8.4/9.8 ³⁾	11.4/14.1 ³⁾

¹⁾ Version without thermowell: minus 0.2 kg

²⁾ Valve also with flanged body

³⁾ Flanged body

Table 4: Type 43-5 and Type 43-6
(G ½ to 1)

Connection	G ½	G ¾	G 1
Length L	65	75	90
Temperature regulator	Weight in kg (approx.) · Version with bulb sensor and thermowell ¹⁾		
Type 43-5	1.8	1.9	2
Type 43-6	1.8	1.9	2

¹⁾ Version without thermowell: minus 0.2 kg

Table 5: Type 43-6 and Type 43-7 · Special version with flanged body

Temperature regulator		DN	Height H	Sensor Ø
Type 43-6	Without separating piece	15 to 25	190	Ø 9.5
Type 43-6		32 to 50	210	Ø 12
Type 43-7	With separating piece	15 to 25	260	Ø 9.5
Type 43-7		32 to 50	310	Ø 12

9 Technical data

Table 6: *Technical data · All pressures in bar (gauge)*

Temperature regulator	Type 43-6	43-5	43-7
Valve	2436	2435	2437
Connection size	G ½ to 1	G ½ to 1	–
Valve size	DN 32 to 50	–	DN 15 to 50
Flanged body (special version)	DN 15 to 50	–	DN 15 to 50
Pressure rating	PN 25		
Max. permissible differential pressure Δp	With corrosion-resistant operating bellows: 16 bar ²⁾		
Perm. permissible temperature range of valve	0 to 150 °C ¹⁾	0 to 200 °C	
Type 2430 Control Thermostat			
Set point range ³⁾	Continuously adjustable: 0 to 35 °C, 25 to 70 °C, 40 to 100 °C, 50 to 120 °C or 70 to 150 °C		
Capillary tube	2 m (5 m as special version)		
Max. permissible temperature at sensor	50 K above the adjusted set point		
Permissible ambient temperature range	–20 to 80 °C		
Permissible pressure at sensor/thermowell	PN 25/PN 40		

1) With intermediate insulating piece –15 to 150 °C

2) Types 43-6, 43-7: max. 8 bar

3) Further set point ranges on request

Table 7: *K_{VS} coefficients*

K _{VS} coefficients for ...						
Connection size	G ½	G ¾	G 1	–		
Valve size	DN 15 ^{1) 2)}	DN 20 ¹⁾	DN 25 ^{1) 2)}	DN 32 ¹⁾	DN 40 ¹⁾	DN 50 ¹⁾
K _{VS} coefficient	3.2	4.0	5.0	12.5	16	20
Special version	0.4 · 1.0 · 2.5 ³⁾			–		

1) Flanged body of spheroidal graphite iron, Type 43-6/43-7 (special version)

2) Flanged body of stainless steel, Type 43-6 (special version)

3) On request

EB 2172 EN



SAMSON AKTIENGESELLSCHAFT
Weismüllerstraße 3 · 60314 Frankfurt am Main, Germany
Phone: +49 69 4009-0 · Fax: +49 69 4009-1507
samson@samson.de · www.samson.de