

SH 3995 EN

Translation of original instructions

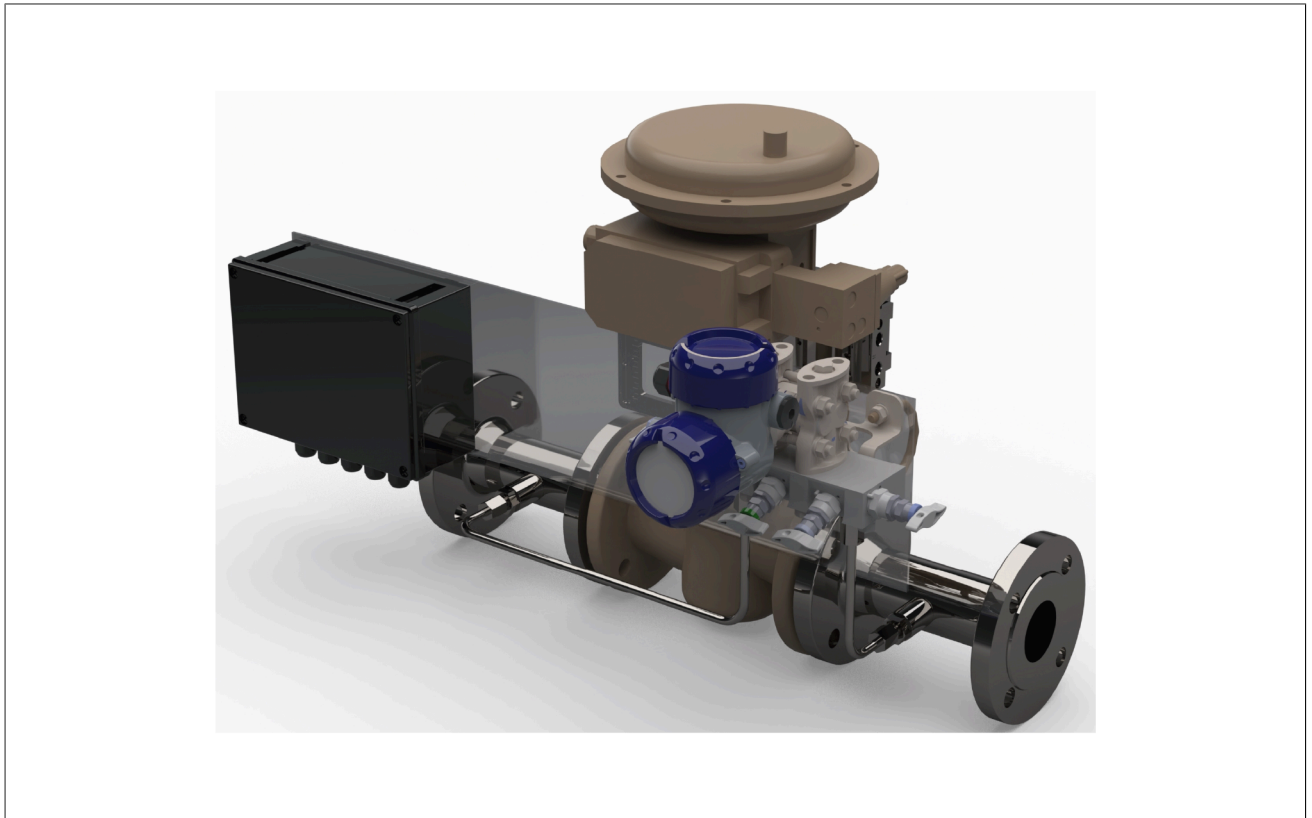

Type 7301 Single-channel Backflow Protection Unit

Definition of signal words

⚠ DANGER

Hazardous situations which, if not avoided, will result in death or serious injury

⚠ WARNING

Hazardous situations which, if not avoided, could result in death or serious injury

ⓘ NOTICE

Property damage message or malfunction

i Note

Additional information

💡 Tip

Recommended action

Purpose of this manual

The Safety Manual SH 3995 EN contains information relevant to the use of the Type 7301 Backflow Protection Unit in safety-instrumented systems according to IEC 61508/IEC 61511. The safety manual is intended for planners, constructors and operators of safety-instrumented systems.

Further documentation

A differential pressure sensor is used in the Type 7301 Single-channel Backflow Protection Unit to monitor the medium flow across the valve assembly. The following valve assembly components are relevant for safety-instrumented function: valve, actuator and solenoid valve.

The documents listed below contain descriptions of the individual components of the unit. Operating personnel must read and understand the referenced mounting and operating instructions before operating or working on the individual components (e.g. service and repair work).

You can download the listed documents from

▶ www.samsongroup.com.

Globe valves

- Type 3241 (DIN version)
Data Sheet ▶ T 8015
Mounting and Operating Instructions ▶ EB 8015
Safety Manual ▶ SH 8015
- Type 3241 (ANSI version)
Data Sheet ▶ T 8012
Mounting and Operating Instructions ▶ EB 8012
Safety Manual ▶ SH 8015
- Type 3251 (DIN version)
Data Sheet ▶ T 8051
Mounting and Operating Instructions ▶ EB 8051
Safety Manual ▶ SH 8051
- Type 3251 (ANSI version)
Data Sheet ▶ T 8052
Mounting and Operating Instructions ▶ EB 8052
Safety Manual ▶ SH 8051
- Type 3510 (DIN version)
Data Sheet ▶ T 8091
Mounting and Operating Instructions ▶ EB 8091
Safety Manual ▶ SH 8091
- Type 3510 (ANSI version)
Data Sheet ▶ T 8091-1
Mounting and Operating Instructions
▶ EB 8091-1
Safety Manual ▶ SH 8091

Pneumatic rotary actuator

- Type 31a
Data Sheet ▶ T 31a
Mounting and Operating Instructions ▶ EB 31a
Safety Manual ▶ SH 31a

Pneumatic linear actuators

- Type 3271 and Type 3277
Data Sheet ▶ T 8310-X
Mounting and Operating Instructions
▶ EB 8310-X
Safety Manual ▶ SH 8310

Solenoid valves

- Type 3963
Data Sheet ▶ T 3963
Mounting and Operating Instructions ▶ EB 3963
Safety Manual ▶ SH 3963
- Type 3967
Data Sheet ▶ T 3967
Mounting and Operating Instructions ▶ EB 3967
Safety Manual ▶ SH 3967
- Type 3969
Data Sheet ▶ T 3969
Mounting and Operating Instructions ▶ EB 3969
Safety Manual ▶ SH 3969

i Note

In addition to the listed documentation, observe the requirements specified in the technical documentation for the positioner (mounted on the valve assembly), differential pressure sensors and JUMO safetyM STB/STW safety temperature limiter as well as the order documents (general arrangement drawing, wiring plan etc.).

1	Scope.....	6
1.1	Use in safety-instrumented systems.....	6
1.2	Versions.....	6
1.3	Mounting.....	6
2	Technical data.....	7
3	Safety-instrumented function.....	8
3.1	Safety behavior.....	8
3.2	Protection against unauthorized changes to the configuration.....	8
4	Mounting, connection and start-up.....	9
4.1	Electrical connection.....	9
4.2	Pneumatic connection.....	9
5	Required conditions.....	10
5.1	Special application to monitor a batch process.....	10
6	Proof testing.....	12
6.1	Visual inspection to avoid systematic failure.....	12
6.2	Inspection of seat and plug for wear.....	12
6.3	Function testing.....	13
7	Servicing and repairs.....	15
8	Safety-related data.....	16

1 Scope

The Type 7301 Single-channel Backflow Protection Unit is an electropneumatic system, which prevents the medium from flowing back through the pipeline.

The backflow protection unit monitors the medium flow by measuring the differential pressure across the valve assembly. The Type 7301 Backflow Protection Unit is installed in supply networks to protect them.

i Note

For use in safety-instrumented systems, control valves must only be used in combination with a pneumatic actuator which is not fitted with a pneumatic or electric lock-up device, travel stop or handwheel.

1.1 Use in safety-instrumented systems

Observing the requirements of IEC 61508 and IEC 61511, the systematic capability of the Type 7301 Backflow Protection Unit as a standalone safety-instrumented system (SIS) is given.

The Type 7301 Backflow Protection Unit can be used up to SIL 2.

1.2 Versions

All versions of the Type 7301 Single-channel Backflow Protection Unit are suitable for the use in safety-instrumented systems provided the valve assemblies are operated with the components installed in the as-delivered state.

1.3 Mounting

The backflow protection unit is delivered as a flange-to-flange unit. The design and dimensions vary depending on the version. The dimensions of the backflow protection unit used can be found in the order-specific general arrangement drawing.

2 Technical data

Table 1: Components

Item	Designation	Types
01	Valve body	Type 3241/Type 3251/Type 3510 Globe Valve
	Actuator	Type 3271/Type 3277 Pneumatic Actuator
02	Valve block	5-way valve block
03	Differential pressure sensor	E+H Type PMD75
		ABB Type 266 DSH
04		Type 4708/Type 3999 Supply Air Station
05		Type 7401 SIS Logic Solver

Table 2: Technical data

Single-channel backflow protection unit	Type 7301 ¹⁾
Safety integrity level	SIL 2
Process medium	Gases and liquids according to the Data Sheets for Type 3241 Valves (▶ T 8015)/Type 3251 Valves (▶ T 8051). Special applications on request
Nominal size	DN 15 to 200 (larger nominal sizes on request)
Pressure rating	PN 16 to 63 (higher pressure ratings on request)
Standards, directives and regulations	DIN EN 61508; DIN EN 61511; PED; ATEX
Bleed function	Without
Supply	24 V DC/instrument air according to ISO 8573-1
Feedback signal to meet SIL requirements	1x floating contact
Differential pressure to trigger emergency shutdown	50 mbar for liquids; 30 mbar for gases (depending on the safety requirement specification (SRS))

¹⁾ Special customized versions

3 Safety-instrumented function

The emergency shutdown of the backflow protection unit takes place as soon as backflow of the medium cannot be ruled out. Backflow protection units monitor the medium flow by measuring the differential pressure across the valve assembly. Backflow cannot be ruled out once the differential pressure falls below a certain limit. As a result, the backflow protection unit shuts down and isolates the pipeline.

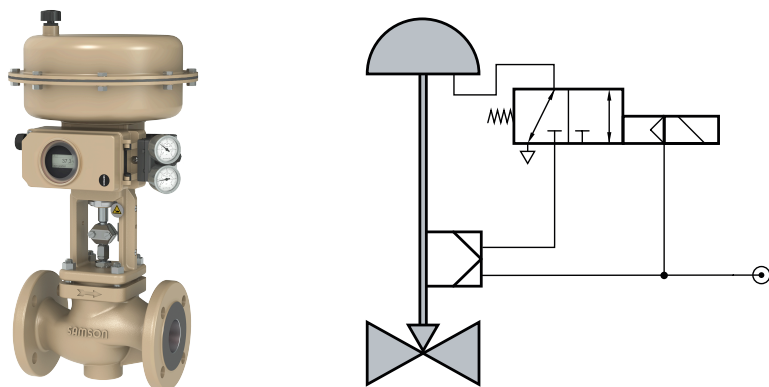

i Note

The integrated BPCS control of the (outlet) valve is not part of the safety-instrumented function since the solenoid valve overrides this function to vent the actuator in the event of emergency.

A second solenoid valve with mounting block (2oo2 architecture) is used for versions with BPCS for on/off control of the backflow protection unit. It is also not part of the safety-instrumented function (see Chapter 5.1).

3.1 Safety behavior

Fail-safe action is triggered when the differential pressure falls below the adjusted limit or when the electric/pneumatic supply fails.

The solenoid valve fully vents the pneumatic actuator to the atmosphere causing the control valve to close (fail-close).

3.2 Protection against unauthorized changes to the configuration

The safety-instrumented function can be influenced by configuration of the analyzer (limit value to trigger emergency shutdown).

All backflow protection units include a *JUMO safetyM STB/STW* analyzer functioning as a safety temperature limiter, which is installed in the SIS logic solver. This device cannot be accessed from the outside, which means it is impossible to change its configuration unintentionally. For even better protection against manipulation, the SIS logic solver can additionally be protected by a code or lead-sealed (see the instructions for *JUMO safetyM STB/STW*). The SIS logic solver is not code-protected or lead-sealed in the delivered state. The operator is responsible for the improved level of protection.

The valve blocks used for the differential pressure sensors are also protected against manipulation. A special drive handle is required to operate these valves. The use of a padlock at the point where the drive handle is inserted can additionally prevent operation. It is no longer possible to operate these valves. The bonnets of the valves installed in the plant are protected against unauthorized access. The operator is responsible for controlling the accessibility and storage location of the drive handle.

4 Mounting, connection and start-up

4.1 Electrical connection

The backflow protection unit consists of two subsystems: pipeline system (process section) and an SIS logic solver (operation interface). A terminal box is mounted on the pipeline system. All field devices are ready-wired to the terminal block in this box.

⇒ Route the connecting cable between the terminal box and valve assembly unit (see the wiring plan of the backflow protection unit).

⚠ WARNING

Incorrect installation will render the explosion protection ineffective.

The backflow protection unit is fitted with intrinsically safe field devices. Suitable barriers are installed in the SIS logic solver. As a result, the overall system is intrinsically safe provided a suitable connecting cable is used.

⇒ *For use in hazardous areas (intrinsic safety), use suitable cables and wires.*

⇒ *Install the process section of the backflow protection unit in the hazardous area. Observe the Ex markings on the nameplate.*

⇒ *Install the SIS logic solver of the backflow protection unit only outside the hazardous area.*

4.2 Pneumatic connection

A central connection for the supply air exists on the process section of the backflow protection unit. This connection is designed as a manifold, which connects all supply air lines when several devices require supply air.

1. Observe the minimum and maximum pressure (see the nameplate).
2. Refer to the general arrangement drawing of the backflow protection unit.
3. Observe the limits of the pipeline components (see the nameplates of the pipeline components).

5 Required conditions

⚠ WARNING

Risk of malfunction due to incorrect selection or wrong installation and operating conditions.

⇒ Only use backflow protection units in safety-instrumented systems if the necessary conditions in the plant are fulfilled.

💡 Tip

SAMSON recommends checking the installation and start-up based on a checklist. Examples of such checklists are included in VDI 2180-2 and the SAMSON brochure WA 236 (Functional Safety of Globe Valves, Rotary Plug Valves, Ball Valves and Butterfly Valves).

A differential pressure sensor is used in the Type 7301 Single-channel Backflow Protection Unit to monitor the medium flow across the valve assembly. The following valve assembly components are relevant for safety-instrumented function: valve, actuator and solenoid valve.

Refer to the safety manuals of the individual components for the necessary conditions.

⇒ The necessary conditions described in the safety manuals of the individual installed components are observed.

Safety manuals (relevant depending on whether components are installed):

- Type 3241 Globe Valve ▶ SH 8015
- Type 3251 Globe Valve ▶ SH 8051
- Type 3510 Globe Valve ▶ SH 8091
- Type 3271 and Type 3277 Pneumatic Actuators (linear actuators) ▶ SH 8310
- Type 3963 Solenoid Valve ▶ SH 3963
- Type 3967 Solenoid Valve ▶ SH 3967
- Type 3969 Solenoid Valve ▶ SH 3969

5.1 Special application to monitor a batch process

The backflow protection unit is normally designed for monitoring of a continuous flow rate. A special application exists to monitor batch processes. In such processes, the continuous flow rate is interrupted. As a result, the backflow protection unit must be fitted with an additional BPCS function.

An additional solenoid valve is mounted in series to the installed solenoid valve (2oo2 architecture). The solenoid valve in the safety-instrumented system overrides the BPCS function of the additional solenoid valve (see Fig. 1). The plant operator is responsible for control of the additional solenoid valve to prevent emergency shutdown triggered by the BPCS.

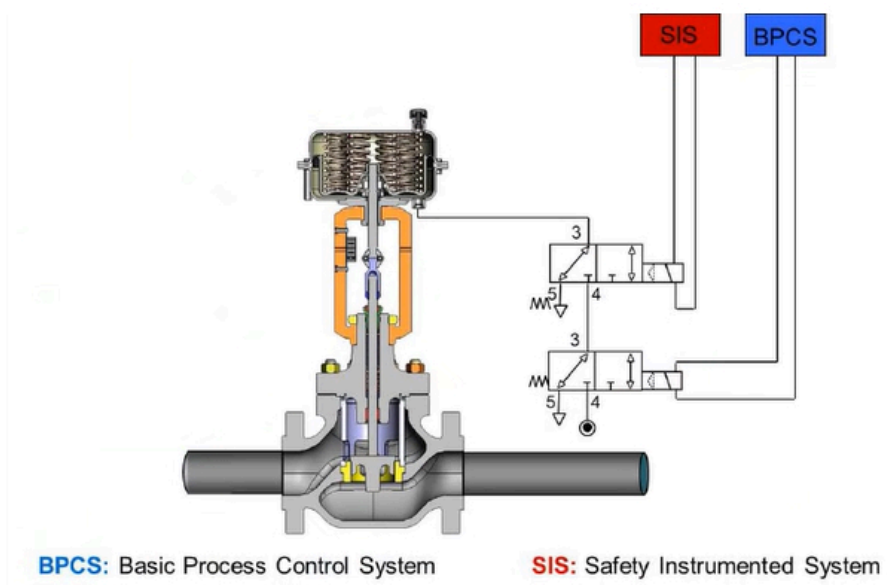

Fig. 1: Special application to monitor a batch process

6 Proof testing

The proof test interval and the extent of testing lie within the operator's responsibility. The operator must draw up a test plan, in which the proof tests and the interval between them are specified. We recommend summarizing the requirements of the proof test in a checklist. The user is responsible for analyzing the test results and taking appropriate action.

NOTICE

Risk of dangerous failure due to malfunction in the event of emergency (actuator is not vented and/or the valve does not move to the fail-safe position).

⇒ Only use devices in safety-instrumented systems that have passed the proof test according to the test plan drawn up by the operator.

Regularly check the safety-instrumented function of the entire SIS loop. The test intervals are determined, for example on calculating each single SIS loop in a plant (PFD_{avg}).

6.1 Visual inspection to avoid systematic failure

To avoid systematic failure, regular visual inspections of the backflow protection unit are necessary. The frequency and the scope of the inspection lie within the operator's responsibility. Take application-specific influences into account, such as:

- Dirt blocking the pneumatic connections
- Corrosion (destruction primarily of metals due to chemical and physical processes)
- Material fatigue
- Aging (damage caused to organic materials, e.g. plastics or elastomers, by exposure to light and heat)
- Chemical attack (organic materials, e.g. plastics or elastomer, which swell, leach out or decompose due to exposure to chemicals)
- External leakage

NOTICE

Risk of malfunction due to the use of unauthorized parts.

⇒ Only use original parts to replace worn parts.

6.2 Inspection of seat and plug for wear

Wear may cause the geometry of the valve seat and plug (valve assembly) to change. This may lead to seat leakage in the valve's closed position.

1. Perform continuous monitoring of the valve seat leakage through the use of valve diagnostic tools. Such suitable tools include the EXPERTplus valve diagnostics integrated in the positioner or the SAM VALVE MANAGEMENT web application.
2. When values exceed the limits defined in the safety requirements specification (SRS), take appropriate action (see the mounting and operating instructions of the valve):
 - Type 3241 (DIN version) ► EB 8015
 - Type 3241 (ANSI version) ► EB 8012
 - Type 3251 (DIN version) ► EB 8051
 - Type 3251 (ANSI version) ► EB 8052
 - Type 3510 (DIN version) ► EB 8091
 - Type 3510 (ANSI version) ► EB 8091-1

6.3 Function testing

Regularly check the safety-instrumented function according to the test plan drawn up by the operator.

i Note

Record any faults of the backflow protection unit and e-mail (aftersalesservice@samsongroup.com) them to SAMSON.

⇒ Perform the tests "Emergency shutdown of the backflow protection unit using the key-operated switch" and "Emergency shutdown of the backflow protection unit over the valve block on the differential pressure sensor" one after the other as described.

Emergency shutdown of the backflow protection unit using the key-operated switch

1. Make sure that shutdown of the backflow protection unit does not cause conditions in the plant to become unsafe.
2. Turn the key-operated switch ("SIL-Kreis AUS/EIN") to the OFF ("AUS") position.
This causes the following actions:
 - The sensor signals are disconnected from the analyzer.
 - The analyzer (*JUMO safetyM STB/STW*) detects a sensor failure and switches off the relay output.
 - The solenoid valve is de-energized causing the actuator (control valve) to vent to the atmosphere.
 - The control valve moves to the fail-safe position.
 - The white indicator lamp "RST AUF" goes out. The yellow LED ("Entspannung") goes on when the bleed function is used.
3. Check that the control valve has moved to its end position.
The control valve must be in the closed position.
4. Check any feedback signals (if they are used) to the higher-level control system.
5. Turn the key-operated switch ("SIL-Kreis AUS/EIN") to the ON ("EIN") position.
6. Press the green button ("SIL-Kreis EIN") to switch on the unit.
The backflow protection unit opens again, provided a differential pressure of the medium exists across the unit.

Emergency shutdown of the backflow protection unit over the valve block on the differential pressure sensor

1. Make sure that shutdown of the backflow protection unit does not cause conditions in the plant to become unsafe.
2. Open the bypass ball valve (middle ball valve) on the valve block of the differential pressure sensor.
This causes the following actions:
 - The differential pressure is the same as the measuring signal of the analyzer (*JUMO safetyM STB/STW*). It drops to 0 mbar. As a result, the differential pressure falls below the limit value to trigger emergency shutdown.
 - The analyzer identifies the limit violation/difference and switches off the relay output.
 - The control valve moves to the fail-safe position.
 - The white indicator lamp "RST AUF" goes out. The yellow LED ("Entspannung") goes on when the bleed function is used.

The control valve must be in the closed position.

3. Check any feedback signals (if they are used) to the higher-level control system.
4. Fully close the bypass ball valves of the sensors.

Proof testing

5. Turn the key-operated switch ("SIL-Kreis AUS/EIN") to the ON ("EIN") position.
6. Press the green button ("SIL-Kreis EIN") to switch on the unit.
The backflow protection unit opens again, provided a differential pressure of the medium exists across the unit.

7 Servicing and repairs

Only perform work on the valve assembly components relevant for the safety-instrumented function described in the corresponding mounting and operating instructions.

Mounting and operating instructions:

- Type 3241 Globe Valve (DIN version) ▶ EB 8015
- Type 3241 Globe Valve (ANSI version) ▶ EB 8012
- Type 3251 Globe Valve (DIN version) ▶ EB 8051
- Type 3251 Globe Valve (ANSI version) ▶ EB 8052
- Type 3510 Globe Valve (DIN version) ▶ EB 8091
- Type 3510 Globe Valve (ANSI version) ▶ EB 8091-1
- Type 3271 and Type 3277 Pneumatic Actuators ▶ EB 8310-X
- Type 3963 Solenoid Valve ▶ EB 3963
- Type 3967 Solenoid Valve ▶ EB 3967
- Type 3969 Solenoid Valve ▶ EB 3969

🚫 NOTICE

Safety-instrumented function will be impaired if repair work is performed incorrectly.

⇒ *Only allow trained staff to perform service and repair work.*

Mean time to repair

The mean time to repair depends on the repair work required. Contact SAMSON's After-sales Service concerning any repair work not described in the associated mounting and operating instructions. SAMSON's After-sales Service also provides information on the mean time required to repair for individual cases.

8 Safety-related data

The safety-related data are calculated for each specific order. The order-specific proof of the safety integrity level (SIL) is part of the order documentation.

i Note

Some of the tests described in Chapter 6 are system tests, which are performed to test several components. The resulting proof test coverage (PTC) cannot be directly derived from the values of each individual component. Rather the PTC is determined as part of the order-specific SIL verification of the overall system.



SAMSON AKTIENGESELLSCHAFT
Weismüllerstraße 3 · 60314 Frankfurt am Main, Germany
Phone: +49 69 4009-0 · Fax: +49 69 4009-1507
samson@samsongroup.com · www.samsongroup.com