

**Type 3249-1 and Type 3249-7  
Pneumatic Control Valves  
Type 3249 Aseptic Angle Valve**

**SAMSON**



Ball body version



Special version with packing

Type 3249-7 Control Valve with Type 3277 Actuator and integrated positioner

**Mounting and  
Operating Instructions**

**EB 8048 EN**

Edition November 2016



## Definition of signal words



### **DANGER!**

*Hazardous situations which, if not avoided, will result in death or serious injury*



### **WARNING!**

*Hazardous situations which, if not avoided, could result in death or serious injury*



### **NOTICE**

*Property damage message or malfunction*



### **Note:**

*Additional information*



### **Tip:**

*Recommended action*

1	<b>General safety instructions</b> .....	4
2	<b>Process medium and scope of application</b> .....	5
2.1	Transportation and storage .....	5
3	<b>Design and principle of operation</b> .....	5
4	<b>Connection between valve and actuator</b> .....	8
4.1	Assembly and adjustment .....	8
4.2	Option of preloading springs for fail-safe action "actuator stem extends" .....	9
5	<b>Installation</b> .....	9
5.1	Signal pressure line .....	10
6	<b>Operation</b> .....	10
6.1	Start-up.....	10
7	<b>Maintenance</b> .....	10
7.1	Replacing sealing parts and plug .....	11
8	<b>Nameplates</b> .....	13
9	<b>Customer service</b> .....	14

**Note:**

Refer to the Data Sheet ► T 8048 for the technical data as well as dimensions and weights for the Type 3249-1 and Type 3249-7.

For further product documentation go to the website of SAMSON AG.

---



### 1 General safety instructions

- The control valve must be mounted, started up or serviced by fully trained and qualified personnel only; the accepted industry codes and practices are to be observed. Make sure employees or third persons are not exposed to any danger.
- All safety instructions and warnings given in these mounting and operating instructions, particularly those concerning installation, start-up and maintenance, must be strictly observed.
- According to these mounting and operating instructions, trained personnel refers to individuals who are able to judge the work they are assigned to and recognize possible dangers due to their specialized training, their knowledge and experience as well as their knowledge of the applicable standards.
- The control valves comply with the requirements of the European Pressure Equipment Directive 2014/68/EU. Valves with a CE marking have a declaration of conformity which includes information about the applied conformity assessment procedure. The declaration of conformity is available at [www.samson.de](http://www.samson.de).
- To ensure appropriate use, only use the device in applications where the operating pressure and temperatures do not exceed the specifications used for sizing the regulator at the ordering stage.
- The manufacturer does not assume any responsibility for damage caused by external forces or any other external factors.
- Any hazards that could be caused in the valve by the process medium, operating pressure or by moving parts are to be prevented by taking appropriate precautions.
- Proper transport, storage, installation, operation and maintenance are assumed.



**Note:**

*Non-electric actuators and control valve versions do not have their own potential ignition source according to the ignition risk assessment stipulated in EN 13463-1: 2009, section 5.2, even in the rare incident of an operating fault. Therefore, they do not fall within the scope of Directive 2014/34/EU. For connection to the equipotential bonding system, observe the requirements specified in section 6.4 of EN 60079-14 (VDE 0165 Part 1).*

## 2 Process medium and scope of application

Control valve for aseptic applications in the food and pharmaceutical industries according to DIN or ANSI standards.

Nominal sizes	DN 15 to 100	·	NPS ½ to 4
Maximum pressure	10 bar	·	150 psi
Temperature range	0 to 160 °C	·	32 to 320 °F

### 2.1 Transportation and storage

The valve must be carefully handled, transported and stored. Protect the valve against adverse influences, such as dirt, moisture or frost, during storage and transportation.

When valves are too heavy to be lifted by hand, fasten the lifting sling at a suitable place on the valve or valve bonnet.



#### **NOTICE**

*Do not attach any lifting equipment, slings or supports to mounting parts, such as actuator, positioner or pressure lines.*

---

## 3 Design and principle of operation

See Fig. 1 on page 7.

The Type 3249 Angle Valve can be combined with either a Type 3271 Pneumatic Actuator or a Type 3277 Pneumatic Actuator with integral positioner attachment.

#### **Standard version**

Angle valve in ball body design, with clamp connection of the bonnet without packing. The stem is sealed by an EPDM diaphragm with PTFE facing.

#### **Special version**

Angle valve with screwed-on valve bonnet and additional V-ring packing

The standard valve body is equipped with welding ends for welding into pipelines. Special versions are equipped with threaded or flanged ends, or clamp connections.

The valve body is designed without cavities, allowing it to be cleaned or sterilized prior to the production process according to the CIP (clean-in-place) or SIP (sterilization-in-place) method.

A test connection (4.4) on the special version with packing (4.2) enables pressure monitoring.

The medium flows through the valve in the direction indicated by the arrow. The plug (3) is moved by changing the signal pressure applied to the diaphragm of the actuator.

The plug stem (6) is connected to the actuator stem (8.1) by the stem connector. The plug stem is sealed by the diaphragm (6.3), and in the special version additionally by the backup packing.

### Fail-safe action

Depending on how the compression springs (8.3) are arranged in the actuator, the valve has two different fail-safe positions:

### Actuator stem extends

When the signal pressure is reduced or the air supply fails, the springs move the actuator stem downwards and close the valve.

The valve opens when the signal pressure is increased enough to overcome the force exerted by the springs.

### Actuator stem retracts

When the signal pressure is reduced or the air supply fails, the springs move the actuator stem upwards and open the valve.

The valve closes when the signal pressure is increased enough to overcome the force exerted by the springs.

Legend for Fig. 1:

- 1 Valve body
- 3 Plug
- 4.1 Spring
- 4.2 Packing
- 4.3 Washer
- 4.4 Test connection
- 5 Valve bonnet
- 5.1 Guide bushing
- 5.2 Threaded bushing
- 5.3 Yoke
- 5.4 Screws
- 5.5 Travel indicator scale
- 5.6 Washer
- 6 Plug stem
- 6.1 Stem connector nut
- 6.2 Lock nut
- 6.3 Diaphragm
- 6.4 Grub screw
- 7 Stem connector
- 8 Actuator
- 8.1 Actuator stem
- 8.2 Ring nut
- 8.3 Compression spring
- 8.4 Rolling diaphragm
- 9 Signal pressure connection
- 10 Vent screw

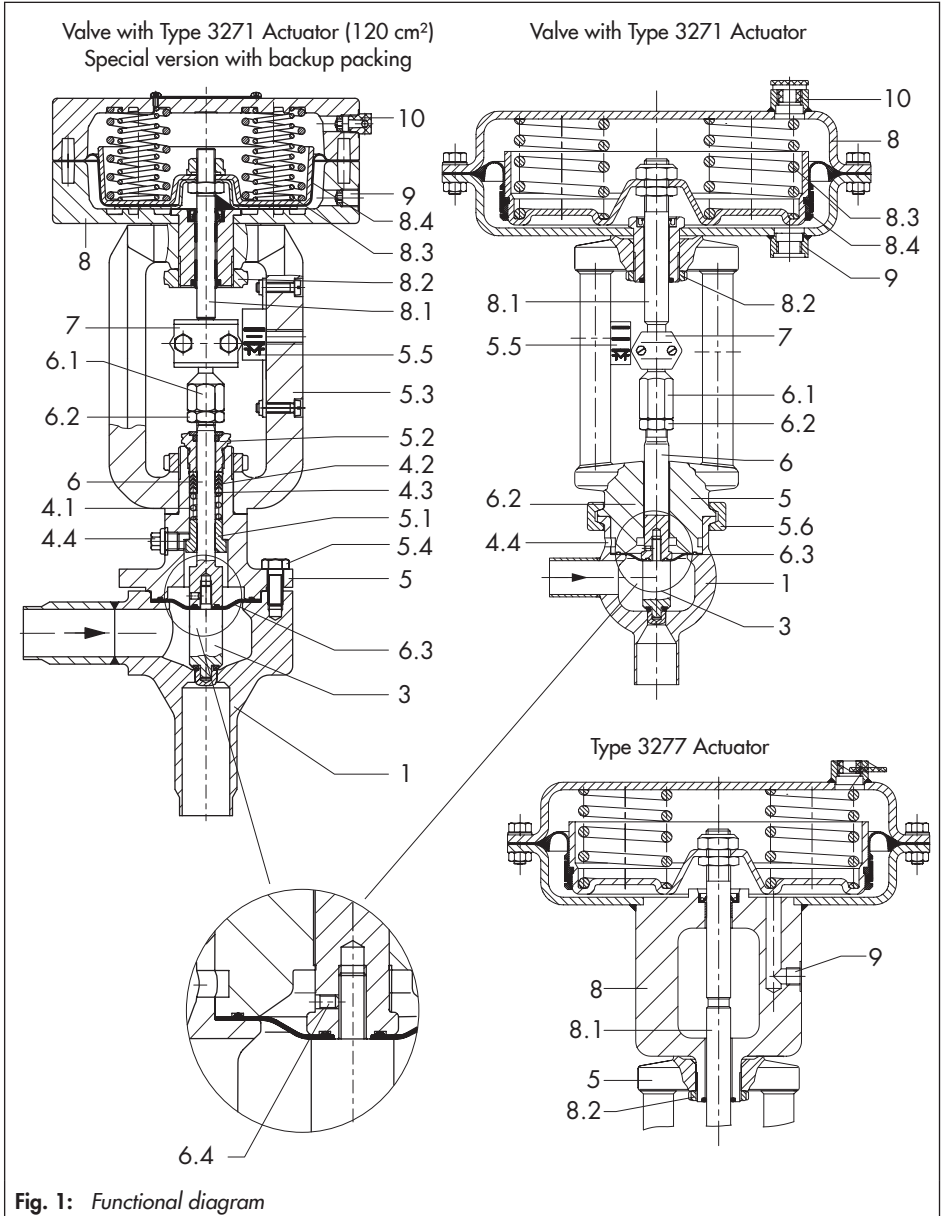

Fig. 1: Functional diagram

## 4 Connection between valve and actuator

The basic pneumatic actuator can be replaced by a pneumatic actuator with additional handwheel or by an electric actuator.

The standard pneumatic actuator can be replaced by a smaller or larger actuator for all nominal valve sizes.

If the travel range of the actuator is larger than the travel of the valve, the springs in the actuator are preloaded by the manufacturer so that the travel ranges match.

### 4.1 Assembly and adjustment

See Fig. 1 on page 7.

Proceed as follows if the valve and actuator have not been assembled by the manufacturer or if the actuator is to be replaced by an actuator of another type or size:



#### **NOTICE**

*On tightening or undoing the lock nut (6.2), a wrench must be used to hold the stem connector nut (6.1) stationary. Otherwise the plug stem may rotate and destroy the diaphragm.*

1. Unscrew the lock nut (6.2) and stem connector nut (6.1) on the valve.

Firmly press the plug together with the plug stem into the seat. Thread down the lock nut and stem connector nut.

2. Remove the clamps of the stem connector (7) and ring nut (8.2) from the actuator. Slide the ring nut over the plug stem.
3. Place the actuator onto the valve bonnet (5) and secure it with the ring nut (8.2).
4. Read the bench range (e.g. 0.2 to 1 bar or 0.6 to 1 bar) and the actuator's fail-safe action (e.g. actuator stem extends) from the actuator's nameplate.

The fail-safe action "actuator stem extends" or "actuator stem retracts" is marked by FA or FE on the Type 3271 Actuator, and by a corresponding symbol on the nameplate of the Type 3277 Actuator.

The lower value corresponds to the lower bench range value to be adjusted, whereas the upper value corresponds to the upper bench range value.

5. For actuators with fail-safe action "actuator stem extends", apply a signal pressure that corresponds to the lower bench range value (e.g. 0.2 or 0.6 bar) to the connection on the bottom diaphragm chamber. For actuators with fail-safe action "actuator stem retracts", apply a signal pressure that corresponds to the upper bench range value (e.g. 1 bar) to the top diaphragm chamber connection.
6. Screw on the stem connector nut (6.1) by hand until it touches the actuator stem (8.1). Then turn it a further  $\frac{1}{4}$  turn and secure this position with the lock nut.
7. Position clamps of the stem connector (7) and screw them tight. Align travel indicator scale (5.3) with the tip of the stem connector; for actuators with fail-safe ac-



tion "actuator stem extends" align it with lower marking (valve closed) and for actuators with fail-safe action "actuator stem retracts" align it with top marking (valve open).



**Note:**

When removing an actuator with fail-safe action "actuator stem extends" and especially an actuator with preloaded springs, apply a signal pressure that is slightly higher than the lower bench range value (see actuator nameplate) to the bottom loading pressure connection so that the ring nut (8.2) can be unscrewed.

When adjusting the valve, the lower bench range value must now be set to 0.3 bar. The new bench range of 0.3 to 1.1 bar must be marked on the nameplate as bench range with pretensioned springs.



**Note:**

*The springs have already been pretensioned by 50 % for valves in nominal sizes DN 15 to 25 with 7.5 mm travel, 0.6 to 1 bar bench range and fail-safe action "actuator stem extends".*



**NOTICE**

*Actuators that have already been preloaded by the manufacturer without mounting the valve are labeled correspondingly. Additionally, they can be identified by three longer bolts with nuts protruding from the bottom diaphragm case. Before starting any work on the valve, relieve the compression from the preloaded springs by unthreading the nuts on the long bolts a few turns, alternating between them to gradually release the tension.*

## 4.2 Option of preloading springs for fail-safe action "actuator stem extends"

To achieve a greater positioning force, the springs of the actuators can be preloaded by up to 12.5 % of their travel or bench range (with 350 cm<sup>2</sup> up to 25 % of their travel or bench range).

When a preload of, e.g. 0.1 bar, is desired for a bench range of 0.2 to 1 bar, the lower bench range value is shifted by 0.1 bar to 0.3 bar (0.1 bar correspond to a preload of 12.5 %).

## 5 Installation

See Fig. 1 on page 7.

Install the control valve with the actuator in the upright position.



### **NOTICE**

*In valve versions with welding ends, the entire bonnet assembly must be removed from the valve body after undoing the clamp (5.4) to allow it to be welded into the pipeline.*

---

Flush and clean the pipeline thoroughly before installing the valve.



### **NOTICE**

*Make sure the valve is installed free of stress. If necessary, support the pipelines near the connections. Do not attach supports directly to the valve or actuator.*

---

### 5.1 Signal pressure line

Connect the signal pressure line for valves with actuator with fail-safe action "actuator stem extends" to the connection on the bottom diaphragm case, and for valves with actuator with fail-safe action "actuator stem retracts" actuator to the connection on the top diaphragm case.

In the Type 3277 Actuator, the bottom signal pressure connection is located at the side of the yoke under the bottom diaphragm case.

## 6 Operation

See Fig. 1 on page 7.

To reverse the fail-safe action of the pneumatic actuator, refer to the Mounting and Operating Instructions of the actuator:

**EB 8310-... EN** for Type 3271 and  
**EB 8311 EN** for Type 3277

## 6.1 Start-up

First start up the control valve after mounting all the parts.

---

**!** **NOTICE**  
 Avoid surges in signal pressure as they may damage the rolling diaphragm.

---

As a general rule: open and close shut-off valves slowly. Open the shut-off valves first on the upstream pressure side. Afterwards, open all the valves on the consumer side (downstream of the valve).

---

**i** **Note:**  
 Replace the test connection (screw, 4.4) with a pressure sensor to monitor the diaphragm (6.3) for leaks.

---

## 7 Maintenance

See Fig. 1 on page 7.

The control valve is subject to normal wear, especially at the seat and plug. Depending on the operating conditions, check the valve at regular intervals to prevent possible failure before it can occur.

If leakage occurs, this could be caused by a damaged diaphragm (6.3) or the PTFE V-ring packing (4.2) may be defective in the special version.

If the valve does not close tightly, tight shut-off may be impaired by dirt stuck between the seat and plug or by damaged facings.

We recommend removing the parts, cleaning them, and, if necessary, replacing them with new ones.

---

**!** **NOTICE**  
 Before starting any work on the valve body, disconnect the signal pressure and remove the signal pressure line as well as the actuator. Make sure that none of the process medium is in the pipeline.  
 When used at high temperatures, allow the plant section to cool down to ambient temperature.  
 Actuators with preloaded springs are labeled correspondingly and can also be identified by three long bolts protruding from the bottom of the actuator. Special care is needed in this case. Before starting any work on the valve, relieve the compression from the preloaded springs by unthreading the nuts on the long bolts a few turns, alternating between them to gradually release the tension.

---

### 7.1 Replacing sealing parts and plug

---

**!** **NOTICE**  
 Before starting any work on the valve body, first remove the actuator.

---



**Note:**

*In older versions delivered before August 2008, the plug is stuck with adhesive. To replace the plug, follow the instructions written in the January 2005 edition of EB 8048.*

1. Apply a signal pressure that is higher than the lower bench range value (see nameplate) to the actuator.
2. Remove the stem connector clamps (7) between the actuator stem and the plug stem and unscrew the ring nut (8.2).
3. Lift the actuator off the valve.
4. Remove nuts (6.1 and 6.2).
5. Take off the clamp (5.6) or unscrew the screws (5.4) on the valve bonnet in the special version with packing. Carefully remove the valve bonnet (5) together with plug (3) and diaphragm (6.3). In the special version with packing, also unscrew the threaded bushing (5.2).
6. Pull plug stem (6) together with plug (3) and diaphragm (6.3) out of the valve bonnet. Remove the stopper (4.4) in the special version. Unscrew threaded bushing (5.2), remove packing rings (4.2), washer (4.3) and spring (4.1). Carefully clean the packing chamber.
7. Unscrew grub screw (6.4) on the plug. Clamp the plug into a vice using plastic jaws (SAMSON order no. 1281-0053). Unscrew the plug stem.
8. Remove the damaged diaphragm.

9. Remove the plug and insert a new diaphragm. To prevent seizure, apply lubricant (order no. 1400-6991) to the threads of the plug stem and plug.
10. To prevent any damage, place the plug in a suitable clamping fixture and tighten the plug stem using the two locking nuts at the end of the plug stem.

Observe the following tightening torques:

Nominal size	Tightening torque
DN 15 to 25 NPS ½ to 1	10 Nm
DN 32 to 100 NPS 1¼ to 4	70 Nm

11. Secure plug with grub screw.



**NOTICE**

*In DN 15 to 25, check the concentricity of the plug to the plug stem. It must not be more than 0.04 mm at the maximum.*

12. Slide the plug stem with assembled plug into the valve bonnet. In the special version with packing, slide the spring (4.1), washer (4.3) and new packing rings over the plug stem into the packing chamber. Insert the threaded bushing (5.2) and tighten it as far as it will go.
13. Apply the lubricant suitable for foodstuffs (order no. 8150-9002) to the clamp (5.6) and the flanges of the valve bonnet and valve body. Carefully place the valve bonnet on the valve body.

14. Place the clamp in position and tighten the clamp screw. Hit the clamp lightly with a plastic hammer and tighten the clamp screw again. Repeat this procedure several times to tighten the clamp as far as it will go.
15. Thread the lock nut (6.2) and nut (6.1) loosely onto the plug stem (6).
16. Mount the actuator and adjust the upper and lower bench range values as described in section 4.1 on page 8.

## 8 Nameplates

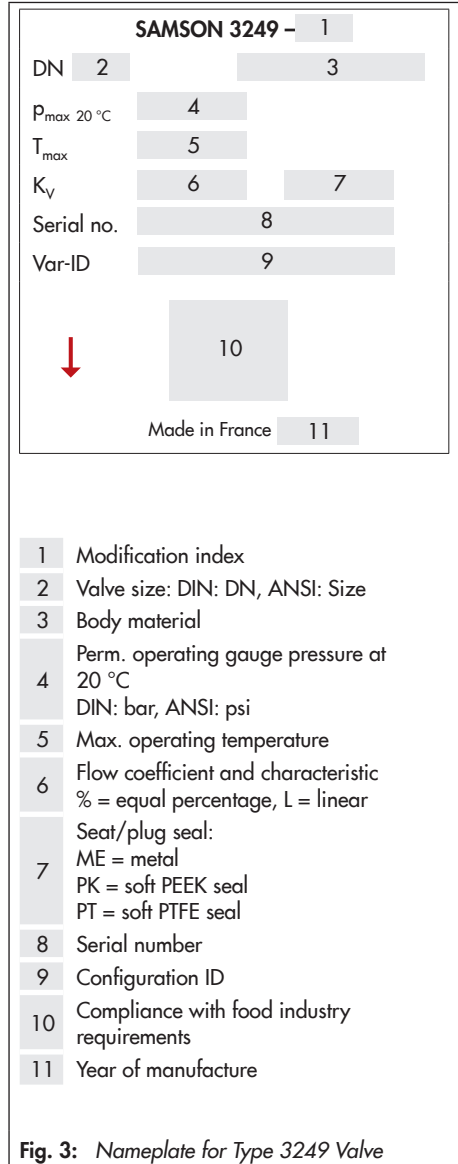
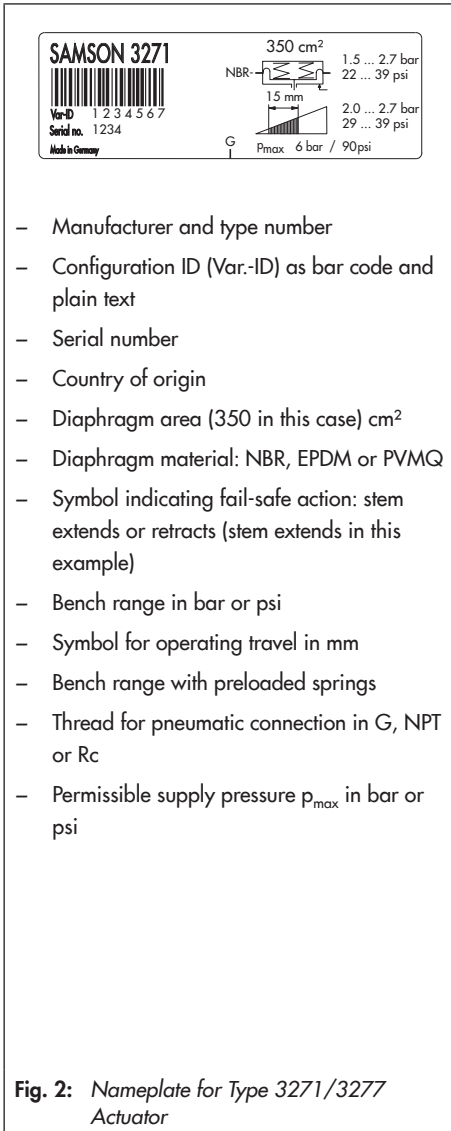

## 9 Customer service

If malfunctions or defects occur, contact the SAMSON After-sales Service Department for support.

The addresses of SAMSON AG, its subsidiaries, representatives and service facilities worldwide can be found on the SAMSON website, in all SAMSON product catalogs or on the back of these Mounting and Operating Instructions.

Please send your inquiries to: [service@samson.de](mailto:service@samson.de)

To assist diagnosis and in case of an unclear mounting situation, specify the following details (see section 8 on page 14):

- Type designation (valve, actuator) and nominal size of the valve
- Serial number and configuration ID (Var-ID)
- Upstream and downstream pressure
- Process medium and its temperature
- Is a strainer installed?
- Installation drawing showing the exact location of the valve and all the additionally installed components (shut-off valves, pressure gauge, etc.)
- Bench range of the actuator (e.g. 0.2 to 1 bar)

Nameplates are attached to the valve and the actuator.



SAMSON AG · MESS- UND REGELTECHNIK  
Weismüllerstraße 3 · 60314 Frankfurt am Main, Germany  
Phone: +49 69 4009-0 · Fax: +49 69 4009-1507  
samson@samson.de · www.samson.de

**EB 8048 EN**

2017-05-18 · English