

MOUNTING AND OPERATING INSTRUCTIONS

SAMSON

EB 8222-1 EN

Translation of original instructions



Type 3310 Segmented Ball Valve with AIR
TORQUE Type SRP/DAP Actuator



Cutaway view of Type 3310 Segmented Ball
Valve with AIR TORQUE Type SRP/DAP
Actuator and positioner

Type 3310 Segmented Ball Valve · Updated edition 2020

In combination with an actuator,
e.g. AIR TORQUE Type SRP/DAP Pneumatic Rotary Actuator or
SAMSON Type 3278 Pneumatic Rotary Actuator

Edition August 2023

CE UK
CA

Note on these mounting and operating instructions

These mounting and operating instructions assist you in mounting and operating the device safely. The instructions are binding for handling SAMSON devices. The images shown in these instructions are for illustration purposes only. The actual product may vary.

- For the safe and proper use of these instructions, read them carefully and keep them for later reference.
- If you have any questions about these instructions, contact SAMSON's After-sales Service (aftersaleservice@samsongroup.com).



Documents relating to the device, such as the mounting and operating instructions, are available on our website at www.samsongroup.com > **Service & Support > Downloads > Documentation.**

Definition of signal words

DANGER

Hazardous situations which, if not avoided, will result in death or serious injury

WARNING

Hazardous situations which, if not avoided, could result in death or serious injury

NOTICE

Property damage message or malfunction

Note

Additional information

Tip

Recommended action

1	Safety instructions and measures	1-1
1.1	Notes on possible severe personal injury	1-4
1.2	Notes on possible personal injury	1-5
1.3	Notes on possible property damage	1-7
1.4	Warnings on the device.....	1-8
2	Markings on the device	2-1
2.1	Valve nameplate	2-1
2.2	Actuator nameplate.....	2-2
2.3	Material identification number	2-2
2.4	Marking to indicate direction of flow	2-2
3	Design and principle of operation	3-1
3.1	Fail-safe action	3-1
3.1.1	Single-acting Type SRP and Type 3278 Pneumatic Rotary Actuators	3-1
3.1.2	Double-acting Type DAP Pneumatic Rotary Actuator	3-4
3.2	Versions	3-4
3.3	Additional fittings.....	3-4
3.4	Valve accessories	3-4
3.5	Technical data	3-5
4	Shipment and on-site transport	4-1
4.1	Accepting the delivered goods	4-1
4.2	Removing the packaging from the valve.....	4-1
4.3	Transporting and lifting the valve.....	4-1
4.3.1	Transporting the valve	4-2
4.3.2	Lifting the valve.....	4-3
4.4	Storing the valve	4-4
5	Installation	5-1
5.1	Installation conditions	5-1
5.2	Preparation for installation.....	5-2
5.3	Mounting the device.....	5-6
5.3.1	Mounting the actuator onto the valve.....	5-6
5.3.2	Installing the valve into the pipeline	5-9
5.3.3	Signal pressure connection	5-10
5.4	Testing the installed valve.....	5-10
5.4.1	Leakage	5-11
5.4.2	Rotary motion.....	5-11
5.4.3	Fail-safe position.....	5-11
5.4.4	Pressure test.....	5-11

Contents

6	Start-up	6-1
7	Operation	7-1
7.1	Normal operation	7-1
7.2	Manual operation	7-1
8	Malfunctions	8-1
8.1	Troubleshooting	8-1
8.2	Emergency action	8-3
9	Servicing and conversion	9-1
9.1	Periodic testing	9-3
9.2	Preparation for servicing or conversion work	9-3
9.3	Mounting the actuator on the valve after service or conversion work	9-3
9.4	Conversion work	9-4
9.4.1	Changing the fail-safe action	9-4
9.4.2	Changing the characteristic	9-4
9.5	Service work	9-5
9.5.1	Replacing the packing	9-5
9.5.2	Replacing the seat ring	9-6
9.5.3	Replacing the segmented ball, valve shaft and bearings	9-12
9.6	Ordering spare parts and operating supplies	9-12
10	Decommissioning	10-1
11	Removal	11-1
11.1	Removing the valve from the pipeline	11-2
11.2	Removing the actuator from the valve	11-2
12	Repairs	12-1
12.1	Returning devices to SAMSON	12-1
13	Disposal	13-1
14	Certificates	14-1
15	Annex	15-1
15.1	Tightening torques, lubricants and tools	15-1
15.2	Accessories	15-1
15.3	Spare parts	15-1
15.4	After-sales service	15-3
15.5	Information on the UK sales region	15-3

1 Safety instructions and measures

Intended use

The Type 3310 Segmented Ball Valve combined with an actuator, e.g. a SAMSON Type 3278 Pneumatic Rotary Actuator or an AIR TORQUE Type SRP/DAP Pneumatic Rotary Actuator is designed for both throttling and on/off service. The control valve is suitable for liquids, vapors and gases.

The valve with its actuator is designed to operate under exactly defined conditions (e.g. operating pressure, process medium, temperature). Therefore, operators must ensure that the control valve is only used in operating conditions that meet the specifications used for sizing the valve at the ordering stage. In case operators intend to use the control valve in applications or conditions other than those specified, contact SAMSON.

SAMSON does not assume any liability for damage resulting from the failure to use the device for its intended purpose or for damage caused by external forces or any other external factors.

→ Refer to the technical data and nameplate for limits and fields of application as well as possible uses.

Reasonably foreseeable misuse

The control valve is not suitable for the following applications:

- Use outside the limits defined during sizing and by the technical data
- Use outside the limits defined by the valve accessories connected to the valve

Furthermore, the following activities do not comply with the intended use:

- Use of non-original spare parts
- Performing service and repair work not described

Qualifications of operating personnel

The control valve must be mounted, started up, serviced and repaired by fully trained and qualified personnel only; the accepted industry codes and practices must be observed. According to these mounting and operating instructions, trained personnel refers to individuals who are able to judge the work they are assigned to and recognize possible hazards due to their specialized training, their knowledge and experience as well as their knowledge of the applicable standards.

Safety instructions and measures

Personal protective equipment

We recommend checking the hazards posed by the process medium being used (e.g.

▶ GESTIS (CLP) hazardous substances database). Depending on the process medium and/or the activity, the protective equipment required includes:

- Protective clothing, gloves, eye protection and respiratory protection in applications with hot, cold and/or corrosive media
 - Wear hearing protection when working near the valve
 - Hard hat
 - Safety harness, e.g. when working at height
 - Safety footwear, if applicable ESD (electrostatic discharge) footwear
- ➔ Check with the plant operator for details on further protective equipment.

Revisions and other modifications

Revisions, conversions or other modifications of the product are not authorized by SAMSON. They are performed at the user's own risk and may lead to safety hazards, for example. Furthermore, the product may no longer meet the requirements for its intended use.

Safety features

The fail-safe position of the control valve upon air supply or control signal failure depends on the actuator used (see associated actuator documentation). When the valve is combined with a pneumatic rotary actuator fitted with springs, the valve moves to a certain fail-safe position (see the 'Design and principle of operation' section) upon supply air or control signal failure. The fail-safe action of the actuator is the same as its direction of action and is specified on the nameplate of SAMSON actuators.

Warning against residual hazards

To avoid personal injury or property damage, plant operators and operating personnel must prevent hazards that could be caused in the control valve by the process medium, the operating pressure, the signal pressure or by moving parts by taking appropriate precautions. Plant operators and operating personnel must observe all hazard statements, warnings and caution notes in these mounting and operating instructions.

Hazards resulting from the special working conditions at the installation site of the valve must be identified in a risk assessment and prevented through the corresponding safety instructions drawn up by the operator.

Responsibilities of the operator

Operators are responsible for proper use and compliance with the safety regulations. Operators are obliged to provide these mounting and operating instructions as well as the referenced documents to the operating personnel and to instruct them in proper operation. Furthermore, operators must ensure that operating personnel or third parties are not exposed to any danger.

Operators are additionally responsible for ensuring that the limits for the product defined in the technical data are observed. This also applies to the start-up and shutdown procedures. Start-up and shutdown procedures fall within the scope of the operator's duties and, as such, are not part of these mounting and operating instructions. SAMSON is unable to make any statements about these procedures since the operative details (e.g. differential pressures and temperatures) vary in each individual case and are only known to the operator.

Responsibilities of operating personnel

Operating personnel must read and understand these mounting and operating instructions as well as the referenced documents and observe the specified hazard statements, warnings and caution notes. Furthermore, operating personnel must be familiar with the applicable health, safety and accident prevention regulations and comply with them.

Referenced standards, directives and regulations

The control valves comply with the requirements of the European Pressure Equipment Directive 2014/68/EU, Machinery Directive 2006/42/EC, Directive 2016 No. 1105 Pressure Equipment (Safety) Regulations 2016 and Directive 2008 No. 1597 Supply of Machinery (Safety) Regulations 2008. Valves with a CE marking and/or UKCA marking have a declaration of conformity, which includes information about the applied conformity assessment procedure. The 'Certificates' section contains this declaration of conformity.

According to the ignition hazard assessment performed in accordance with Clause 5.2 of ISO 80079-36, the non-electrical control valves do not have their own potential ignition source even in the rare incident of an operating fault. As a result, they do not fall within the scope of Directive 2014/34/EU.

→ For connection to the equipotential bonding system, observe the requirements specified in Clause 6.4 of EN 60079-14 (VDE 0165-1).

Safety instructions and measures

Referenced documentation

The following documents apply in addition to these mounting and operating instructions:

- Mounting and operating instructions for the mounted actuator, e.g. ► EB 8321 for the SAMSON Type 3278 Pneumatic Rotary Actuator
- Mounting and operating instructions for mounted valve accessories (positioner, solenoid valve etc.)
- ► AB 0100 for tools, tightening torques and lubricant
- For oxygen service: Manual ► H 01

The packaging of valve constructed and sized for oxygen service has the following label on it:



- When a substance is used in the device, which is listed as being a substance of very high concern on the candidate list of the REACH regulation:

Information on safe use of the part affected

► www.samsongroup.com > About SAMSON > Material Compliance > REACH

If a device contains a substance listed as a substance of very high concern on the candidate list of the REACH regulation, this is indicated on the SAMSON delivery note.

1.1 Notes on possible severe personal injury

⚠ DANGER

Risk of bursting in pressure equipment.

Valves and pipelines are pressure equipment. Impermissible pressure or improper opening can lead to valve components bursting.

- ➔ Observe the maximum permissible pressure for valve and plant.
- ➔ Before starting any work on the control valve, depressurize all plant sections affected as well as the valve.
- ➔ Drain the process medium from all the plant sections concerned as well as the valve.

1.2 Notes on possible personal injury

WARNING

Risk of burn injuries due to hot or cold components and pipelines.

Depending on the process medium, valve components and pipelines may get very hot or cold and cause burn injuries.

- Allow components and pipelines to cool down or warm up to the ambient temperature.
- Wear protective clothing and safety gloves.

Risk of hearing loss or deafness due to loud noise.

The noise emissions depend on the valve version, plant facilities and process medium.

- Wear hearing protection when working near the valve.

Risk of personal injury due to exhaust air being vented from pneumatically operated components.

While the valve is operating, air is vented from the actuator, e.g. during closed-loop operation or when the valve opens or closes.

- Install the control valve in such a way that vent openings are not located at eye level and the actuator does not vent at eye level in the work position.
- Use suitable silencers and vent plugs.
- Wear eye protection when working in close proximity to the control valve.

WARNING

Crush hazard arising from moving parts.

The valve's segmented ball turns in the valve body which can lead to crush injuries to hands or fingers if they are inserted into the valve.

- Do not insert hands or fingers into the valve body.
- Before working on the control valve, release any energy (in the actuator) which causes the valve shaft to move (e.g. also the spring compression).
- Before working on the control valve, disconnect and lock the pneumatic air supply as well as the control signal.
- Disconnect the supply voltage before performing any work on the control valve.
- Do not impede the rotary motion of the segmented ball by inserting objects into its path.
- Before attempting to unblock a segmented ball after it has become blocked (e.g. due to seizing up after remaining in the same position for a long time), release any energy (in the actuator) which causes the valve shaft to move.

Risk of personal injury due to preloaded springs.

Valves in combination with pneumatic actuators with preloaded springs are under tension.

- Before starting any work on the actuator, relieve the compression from the preloaded springs (see associated actuator documentation).

Risk of personal injury due to residual process medium in the valve.

While working on the valve, residual medium can flow out of the valve and, depending on its properties, cause personal injury, e.g. (chemical) burns.

- If possible, drain the process medium from all the plant sections affected and the valve.
- Wear protective clothing, safety gloves, respiratory protection and eye protection.

⚠ WARNING

Risk of personal injury due to incorrect operation, use or installation as a result of information on the valve being illegible.

Over time, markings, labels and nameplates on the valve may become covered with dirt or become illegible in some other way. As a result, hazards may go unnoticed and the necessary instructions not followed. There is a risk of personal injury.

- Keep all relevant markings and inscriptions on the device in a constantly legible state.
- Immediately renew damaged, missing or incorrect nameplates or labels.

1.3 Notes on possible property damage

ⓘ NOTICE

Risk of valve damage due to contamination (e.g. solid particles) in the pipeline.

The plant operator is responsible for cleaning the pipelines in the plant.

- Flush the pipelines before start-up.

Risk of valve damage due to unsuitable medium properties.

The valve is designed for a process medium with defined properties.

- Only use the process medium specified for sizing the equipment.

Risk of leakage and valve damage due to excessively high or low tightening torques.

Observe the specified torques when tightening control valve components. Excessive tightening torques lead to parts wearing out more quickly. Parts that are too loose may cause leakage.

- Observe the specified tightening torques (▶ AB 0100).

Risk of valve damage due to the use of unsuitable tools.

Certain tools are required to work on the valve.

- Only use tools approved by SAMSON (▶ AB 0100).

! NOTICE

Risk of valve damage due to the use of unsuitable lubricants.

The lubricants to be used depend on the valve material. Unsuitable lubricants may corrode and damage surfaces.

→ Only use lubricants approved by SAMSON (▶ AB 0100).

Risk of the process medium being contaminated through the use of unsuitable lubricants and/or contaminated tools and components.

→ If necessary, keep the valve and the tools used free from solvents and grease.

→ Make sure that only suitable lubricants are used.

1.4 Warnings on the device

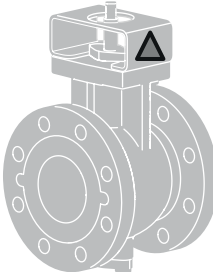
Warning symbols	Meaning of the warning	Location on the device
	<p>Warning against moving parts</p> <p>There is a risk of injury to hands or fingers due to the rotary motion of the segmented ball in the valve body as well as the valve shaft. Hands or fingers may be crushed if inserted into the valve body or yoke and energy from the actuator (e.g. signal pressure or spring compression) causes the valve shaft to move.</p>	

2 Markings on the device

The nameplate shown was up to date at the time of publication of this document. The nameplate on the device may differ from the one shown.

2.1 Valve nameplate

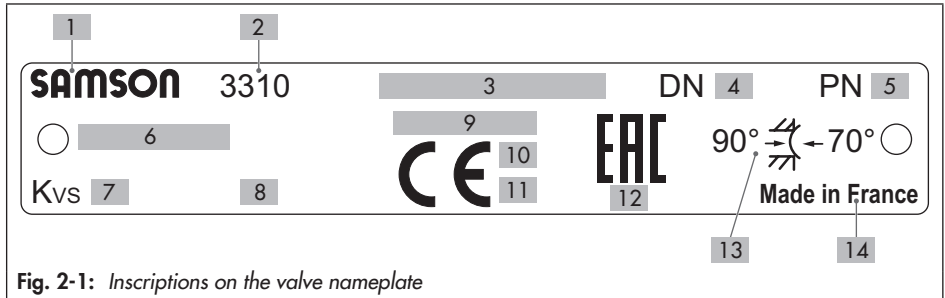

Fig. 2-1: Inscriptions on the valve nameplate

Item	Inscription meaning
1	Manufacturer
2	Type designation
3	Serial no.: 3 —Order number (7-digit number) Order item (2-digit number) Letter code (2 letters)
4	Valve size: DIN: DN ... · ANSI: NPS ... · JIS: DN ...A/NPS ...B
5	Pressure rating: DIN: PN ... · ANSI: Class ... · JIS: K ...
6	Body material
7	Flow coefficient and characteristic: DIN: K_{vs} ... % or LIN · ANSI/JIS: C_v ... % or LIN (%: equal percentage · LIN: linear)

Item	Inscription meaning
8	Seat-plug seal: Unit ARCAP® metal seal PT PTFE PK PEEK 450G Victrex® E Metal seal (E)
9	PED : Pressure Equipment Directive
10	Notified body (PED)
11	Year of manufacture (PED)
12	Month and year of manufacture (TR-CU)
13	Direction of flow and maximum opening angle
14	Country of origin

Markings on the device

The nameplate is affixed to the valve body (see Fig. 2-2).

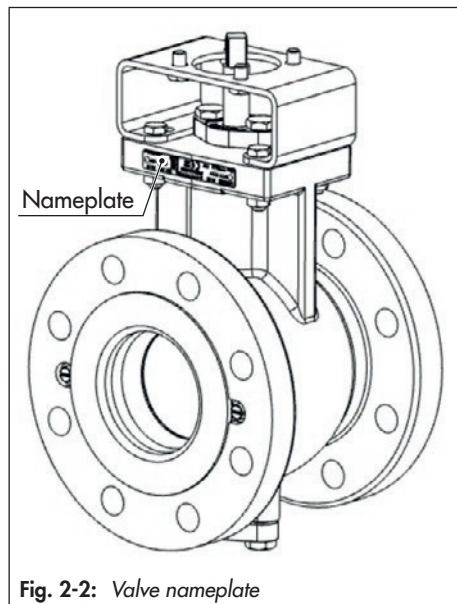

2.4 Marking to indicate direction of flow

The standard direction flow is indicated by an arrow stamped on the side of the valve body. When the reverse direction of flow is used, a mounted label indicates the changed direction of flow.

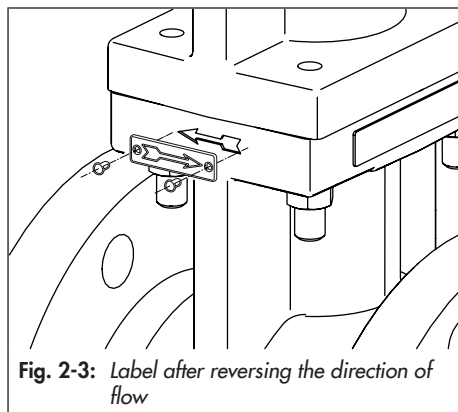

2.2 Actuator nameplate

See associated actuator documentation.

2.3 Material identification number

The seat and segmented ball of the valves have an item number written on them. You can contact us stating this item number to find out which material is used.

3 Design and principle of operation

The Type 3310 Valve is a segmented ball valve. This valve is preferably to be combined with:

- AIR TORQUE Type SRP or Type DAP Pneumatic Rotary Actuator

or

- SAMSON Type 3278 Pneumatic Rotary Actuator

or

- Electric actuator.

The control valve is designed for both throttling and on/off service. The control valve is suitable for liquids, vapors and gases at temperatures from -46 to $+450$ °C and pressure rating of PN 10 to 40/Class 150 and 300.

The segmented ball valve in valve sizes NPS 1 to 12 is available with a soft-seated or metal-seated ball. The version used is marked on the nameplate of the valve body (see the 'Markings on the device' section).

The process medium flows through the valve. The signal pressure applied to the rotary actuator determines the position (opening angle) of the segmented ball (7) and thus the

cross-sectional area of flow between the ball and body (5). The actuator motion is transmitted to the segmented ball valve by the valve shaft (12) with square or key drive. The valve shaft (12) is sealed by a packing (40).

3.1 Fail-safe action

3.1.1 Single-acting Type SRP and Type 3278 Pneumatic Rotary Actuators

The fail-safe position of the valve upon supply air (signal pressure) failure is determined by the version of the single-acting AIR TORQUE Type SRP Pneumatic Rotary Actuator.

The fail-safe position of the valve upon supply air (signal pressure) failure is determined by how the actuator is mounted when a SAMSON Type 3278 Pneumatic Rotary Actuator is used.

Legend for Fig. 3-1 and Fig. 3-2

1	Support shaft	12	Valve shaft	46	Retainer seal
2	Yoke	15	Packing gland	49	Spacer
3	Bottom flange	17	Bearing bushing	70	Retaining screw
4	Insulating section	18	Bearing bushing	80	Washer
5	Valve body	30	Retainer	88	O-ring seal
7	Segmented ball	35	Bushing	90	Gasket
10	Spring	40	Packing		

Design and principle of operation

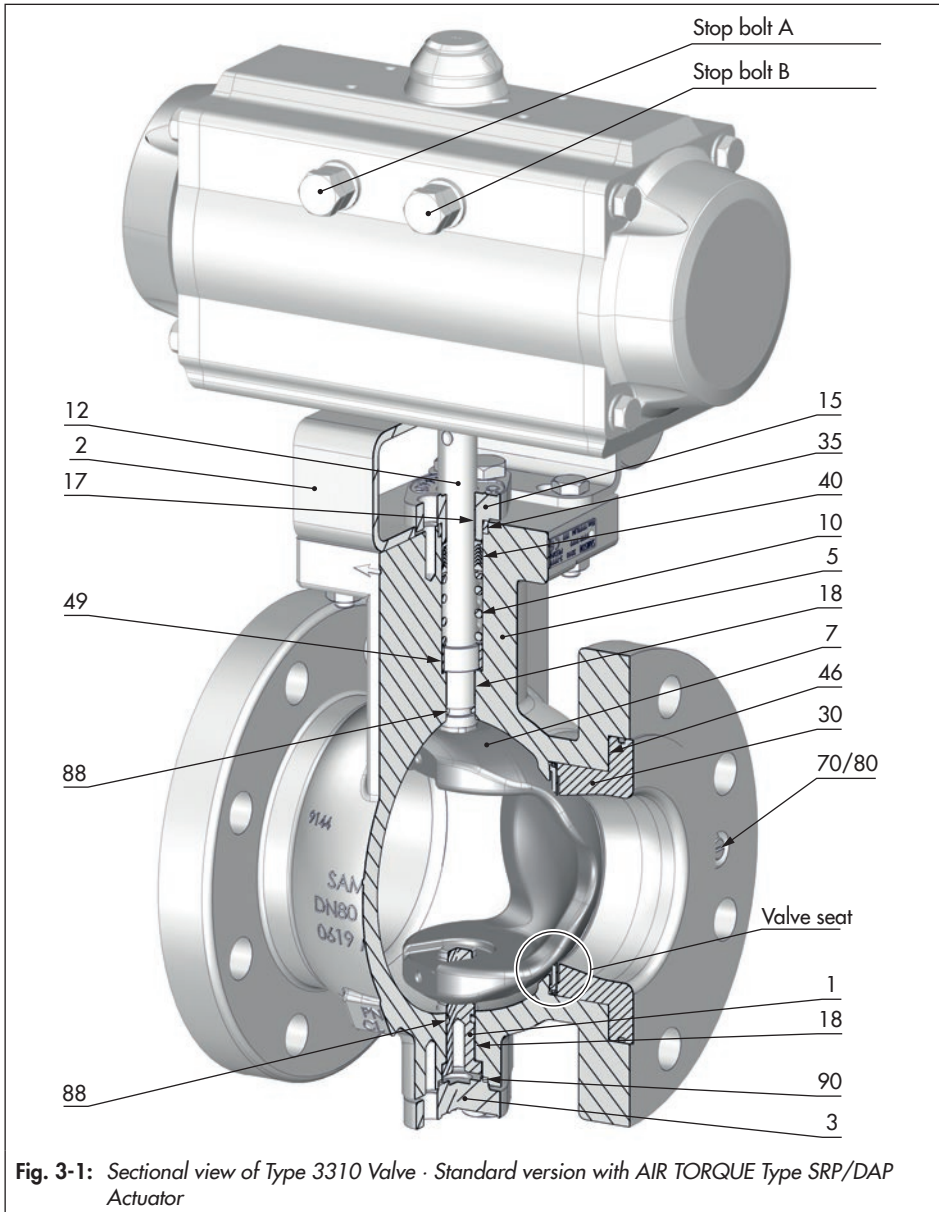

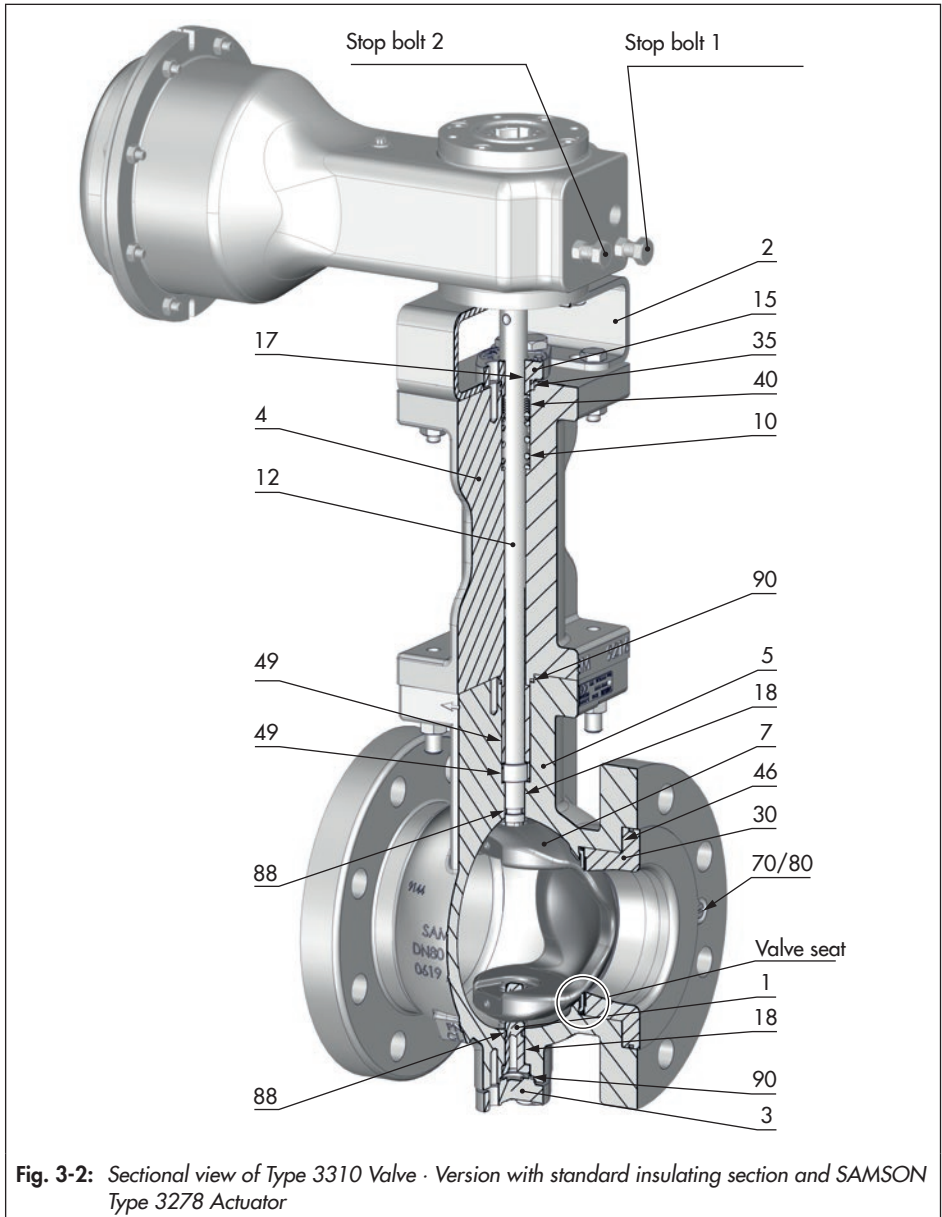

a) Fail-close

When the pressure is relieved from the rotary actuator or the supply air fails, the actuator springs close the valve. The valve opens opposing the force of the actuator springs when the signal pressure increases.

b) Fail-open

When the pressure is relieved from the rotary actuator or the supply air fails, the actuator springs open the valve. The valve closes opposing the force of the actuator springs when the signal pressure increases.

3.1.2 Double-acting Type DAP Pneumatic Rotary Actuator

The double-acting AIR TORQUE Type DAP Rotary Actuator is not fitted with springs. A defined final position is not reached when the supply air fails.

3.2 Versions

Actuators

In these instructions, the preferable combination with a SAMSON Type 3278 Pneumatic Rotary Actuator or AIR TORQUE Type SRP/DAP Pneumatic Rotary Actuator is described. The pneumatic actuator (with or without handwheel) can be replaced by an electric actuator.

3.3 Additional fittings

Bypass and shut-off valves

We recommend installing a shut-off valve both upstream and downstream of the valve and installing a bypass line. The bypass ensures that the plant does not need to be shut down for service and repair work on the valve.

3.4 Valve accessories

The signal pressure connection of the rotary actuator is designed as a borehole with a G 1/8 female thread for small actuators and with G 1/4 female thread for large actuators.

The connection allows in compliance with VDE/VDE 3845 guidelines the connection of a solenoid valve, limit switch or positioner (see Information Sheet ► T 8350). Mounting parts are available for SAMSON valve accessories. See actuator documentation.

3.5 Technical data

The nameplates on the valve and actuator provide information on the control valve version. See the 'Markings on the device' section.

i Note

More information is available in Data Sheet
▶ T 8222-1.

Noise emissions

SAMSON is unable to make general statements about noise emissions. The noise emissions depend on the valve version, plant facilities and process medium.

Design and principle of operation

Table 3-1: Technical data for Type 3310 Valve

Valve seat	Type		Soft seal		Metal seal	
	Version	Material	S		A	E
			PTFE	PEEK	ARCAP®	Enhanced
		PTFE	PEEK	APIC	1.4404/316L and Stellite®	
Pressure rating		PN 10 · 16 · 25 · 40 Class 150/300				
Type of connection	Flanges		DIN EN 1092 ANSI B16.5			
Leakage class according to ANSI/FCI 70-2		VI	VI	IV	IV	
Max. opening angle		90°				
Standard version	DIN	1.0619	-10 to +220 °C (14 to 428 °F)			
		1.4408	-29 to +220 °C (-20 to +428 °F)			
	ANSI	A216 WCC	-29 to +220 °C (-20 to +428 °F)			
		A351 CF8M	-29 to +220 °C (-20 to +428 °F)			
Temperature range	Version with short insulating section	DIN 1.0619	-10 to +220 °C (14 to 428 °F)		-10 to +400 °C ¹⁾ (14 to 752 °F ¹⁾)	-10 to +315 °C ¹⁾ (14 to 599 °F ¹⁾)
		ANSI A216 WCC	-29 to +220 °C (-20 to +428 °F)		-29 to +427 °C ¹⁾ (-20 to +800 °F ¹⁾)	-29 to +315 °C ¹⁾ (-20 to +599 °F ¹⁾)
	DIN and ANSI	1.4408 A351 CF8M	-46 to +220 °C (-51 to +428 °F)	-40 to +220 °C (-40 to +428 °F)	-46 to +450 °C ¹⁾ (-51 to +842 °F ¹⁾)	-46 to +315 °C ¹⁾ (-51 to +599 °F ¹⁾)
Characteristic		Linear or equal percentage				
Rangeability		Equal percentage: R > 400:1 Linear: R > 100:1				
Face-to-face dimensions		DIN EN 558-2 Series 36 ISA 75.08.02				
Conformity						

¹⁾ Only for high-temperature versions ($T_{max} = 220 \text{ °C}$ (428 °F) with standard short insulating section)

Dimensions and weights

Dimensions in mm · Weights in kg

Table 3-2: Dimensions for Type 3310 Valve

Valve	NPS	1	1½	2	3	4	6	8	10	12		
	DN	25	40	50	80	100	150	200	250	300		
Face-to-face dimension according to DIN EN 558-2 Series 36 or ISA 75.08.02	Standard – Form B1 – Raised face (DIN) DEM – Form C – Tongue (DIN) DEF – Form D – Groove (DIN) SEM – Form E – Male face (DIN) SEF – Form F – female face (DIN) RF – Raised Face (ASME)	L (Type 21)	102	114	124	165	194	229	243	297	338	
	LFF – Large Female Face (ASME) SFF – Small Female Face (ASME) LGF – Large Groove Face (ASME) SGF – Small Groove Face (ASME)	L	112	124	134	175	204	239	253	307	348	
	LMF – Large Male Face (ASME) SMF – Small Male Face (ASME) LTF – Large Tongue Face (ASME) STF – Small Tongue Face (ASME)	L	116	128	138	179	208	243	257	311	352	
	Shaft end diameter	Ø d	16	16	16	16	25	25	36	36	36	
	Dimensions of square drive on shaft end	SW ¹⁾	12	12	12	12	19	19	27	27	27	
	Flange connection according to DIN EN ISO 5211	Type SRP/DAP (AIR TORQUE)	F05 VK14 ²⁾	•	•	•	–	–	–	–	–	–
			F07 VK17 ²⁾	•	•	•	•	–	–	–	–	–
			F10 VK22 ²⁾	–	–	•	•	•	•	–	–	–
			F12 VK27 ²⁾	–	–	–	•	•	•	•	•	•
F14 VK36 ²⁾			–	–	–	–	•	•	•	•	•	
F16 VK46 ²⁾			–	–	–	–	–	–	•	•	•	
SAMSON Type 3278		F05 Ø 16	•	•	•	–	–	–	–	–	–	
		F07 Ø 16	•	•	•	•	–	–	–	–	–	
		F10 Ø 25	–	–	–	–	•	•	–	–	–	
		F12 Ø 25	–	–	–	–	•	•	–	–	–	
		A	107	117	126	145	170	206	254	281	281	
		B	72.2	82.2	91.2	110.2	135.2	171.2	198.7	227.2	227.2	
Other dimensions	C	50	50	50	50	55	55	80	80	80		
	Type SRP/DAP (AIR TORQUE)	E	15	15	15	18	23	23	35	35	35	
		SAMSON Type 3278	31	31	31	34.3	49.2	49.2	–	–	–	
	Standard insulating section	F	170	170	170	170	253	253	253	253	253	
	G	100	100	84	84	130	130	150	150	150		
	H	–	–	34	55	58	58	84	84	84		
	Ø I	14	14	10.5	10.5	13	13	17	17	17		
	Ø J	63	63	63	63	78	78	100	100	100		

¹⁾ SW = Width across flats

²⁾ VK = Square drive

Design and principle of operation

Table 3-3: Weights for Type 3310 Valve

Valve	NPS	1	1½	2	3	4	6	8	10	12
	DN	25	40	50	80	100	150	200	250	300
Weights	PN 16 B1	6.6	9.5	11.6	18.3	29.6	46.7	73	98	136
	PN 40 B1	6.6	9.5	12.9	20.9	32.8	52.2	91	129	178
	Class 150 RF	6	7.5	10.4	20.5	31.8	47.2	81.8	107	153
	Class 300 RF	7	10	13.4	23.6	39.1	62.1	102	143	201
Additional weight of standard insulating section		3.7	3.7	4.4	6.9	16.2	16.2	23.2	23.2	23.2

Dimensional drawings

Standard version of Type 3310 Valve

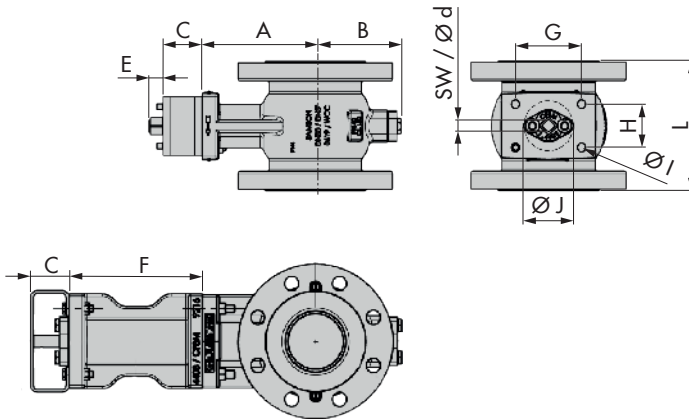

Type 3310 Valve with standard insulating section

i Note

For more dimensions and weights refer to the Data Sheet ► T 8222-1.

The associated actuator documentation applies to actuators, e.g.:

► T 8321 for the SAMSON Type 3278 Pneumatic Rotary Actuator

4 Shipment and on-site transport

The work described in this section is to be performed only by personnel appropriately qualified to carry out such tasks.

4.1 Accepting the delivered goods

After receiving the shipment, proceed as follows:

1. Check the scope of delivery. Check that the specifications on the valve nameplate match the specifications in the delivery note. See the 'Markings on the device' section for nameplate details.
2. Check the shipment for transportation damage. Report any damage to SAMSON and the forwarding agent (refer to delivery note).
3. Determine the weight and dimensions of the units to be lifted and transported in order to select the appropriate lifting equipment and lifting accessories, if required. Refer to the transport documents and the 'Technical data' section.

4.2 Removing the packaging from the valve

Observe the following sequence:

- Do not open or remove the packaging until immediately before lifting to install the valve into the pipeline.

- Leave the control valve in its transport container or on the pallet to transport it on site.
- Do not remove the protective caps from the inlet and outlet until immediately before installing the valve into the pipeline. They prevent foreign particles from entering the valve.
- Dispose and recycle the packaging in accordance with the local regulations.

4.3 Transporting and lifting the valve

⚠ DANGER

Danger due to suspended loads falling.

- *Stay clear of suspended or moving loads.*
 - *Close off and secure the transport paths.*
-

⚠ WARNING

Risk of lifting equipment tipping over and risk of damage to lifting accessories due to exceeding the rated lifting capacity.

- *Only use approved lifting equipment and accessories whose minimum lifting capacity is higher than the weight of the valve (including actuator and packaging, if applicable).*
-

⚠ WARNING

Risk of personal injury due to the control valve tipping over.

- Observe the valve's center of gravity.
- Secure the valve against tipping over or turning.

⚠ WARNING

Risk of injury due to incorrect lifting without the use of lifting equipment.

Lifting the control valve without the use of lifting equipment may lead to injuries (back injury in particular) depending on the weight of the control valve.

- Observe the occupational health and safety regulations valid in the country of use.

ⓘ NOTICE

Risk of valve damage due to incorrectly attached slings.

- When lifting the control valve, make sure that the slings attached to the valve body bear the entire load.
- Do not attach load-bearing slings to the actuator, handwheel or any other parts.
- Observe lifting instructions (see section 4.3.2).

💡 Tip

Our after-sales service can provide more detailed transport and lifting instructions on request.

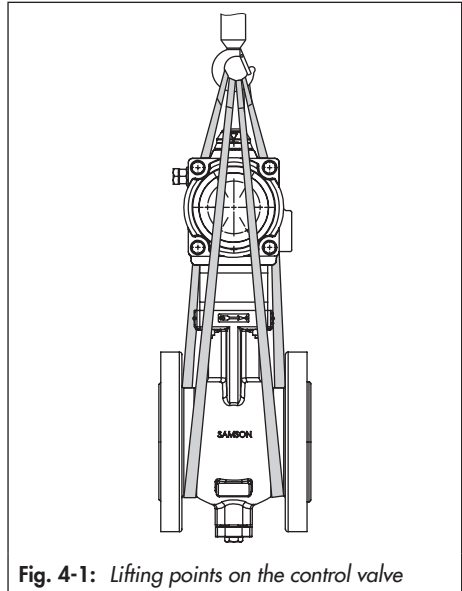

Fig. 4-1: Lifting points on the control valve

4.3.1 Transporting the valve

The control valve can be transported using lifting equipment (e.g. crane or forklift).

- Leave the control valve in its transport container or on the pallet to transport it.
- Observe the transport instructions.

Transport instructions

- Protect the control valve against external influences (e.g. impact).
- Do not damage the corrosion protection (paint, surface coatings). Repair any damage immediately.
- Protect the piping and any mounted valve accessories against damage.
- Protect the control valve against moisture and dirt.

- The permissible transportation temperature of standard control valves is -20 to $+65$ °C/ -4 to $+149$ °F.

i Note

Contact our after-sales service for the transportation temperatures of other valve versions.

4.3.2 Lifting the valve

To install a large valve into the pipeline, use lifting equipment (e.g. crane or forklift) to lift it.

Lifting instructions

- Use a hook with safety latch (see Fig. 4-1) to secure the slings from slipping off the hook during lifting and transporting.
- Secure slings against slipping.
- Make sure the slings can be removed from the valve once it has been installed into the pipeline.
- Prevent the control valve from tilting or tipping over.
- Do not leave loads suspended when interrupting work for longer periods of time.
- Make sure that the axis of the pipeline is always horizontal during lifting and the axis of the valve shaft is always vertical.

Lifting the control valve

1. Attach one sling to each flange of the body and to the rigging equipment (e.g.

hook) of the crane or forklift (see Fig. 4-1).

2. If necessary, attach additional slings that do not bear any load but prevent the control valve from turning or tipping over.
3. Carefully lift the control valve. Check whether the lifting equipment and accessories can bear the weight.
4. Move the control valve at an even pace to the site of installation.
5. Install the valve into the pipeline (see the 'Installation' section).
6. After installation in the pipeline, check whether the flanges are bolted tight and the valve in the pipeline holds.
7. Remove slings.

4.4 Storing the valve

NOTICE

Risk of valve damage due to improper storage.

- Observe the storage instructions.
 - Avoid long storage times.
 - Contact SAMSON in case of different storage conditions or longer storage times.
-

Note

We recommend to regularly check the control valve and the prevailing storage conditions during long storage periods.

Storage instructions

- Protect the control valve against external influences (e.g. impact).
- Do not damage the corrosion protection (paint, surface coatings). Repair any damage immediately.
- Protect the control valve against moisture and dirt. Store it at a relative humidity of less than 75 %. In damp spaces, prevent condensation. If necessary, use a drying agent or heating.
- Make sure that the ambient air is free of acids or other corrosive media.
- The permissible storage temperature of standard control valves is -20 to $+65$ °C/ -4 to $+149$ °F. Contact our after-sales service for the storage temperatures of other valve versions.

- Do not place any objects on the control valve.

Special storage instructions for elastomers

Elastomer, e.g. actuator diaphragm

- To keep elastomers in shape and to prevent cracking, do not bend them or hang them up.
 - We recommend a storage temperature of 15 °C (59 °F) for elastomers.
 - Store elastomers away from lubricants, chemicals, solutions and fuels.
-

Tip

SAMSON's After-sales Service can provide more detailed storage instructions on request.

5 Installation

The work described in this section is to be performed only by personnel appropriately qualified to carry out such tasks.

⚠ WARNING

Crush hazard arising from moving parts.
The valve's segmented ball turns in the valve body which can lead to crush injuries to hands or fingers if they are inserted into the valve.

- *Do not insert hands or fingers into the valve body.*
- *Before working on the control valve, release any energy (in the actuator) which causes the valve shaft to move (e.g. also the spring compression).*
- *Before working on the control valve, disconnect and lock the pneumatic air supply as well as the control signal.*
- *Disconnect the supply voltage before performing any work on the control valve.*
- *Do not impede the rotary motion of the segmented ball by inserting objects into its path.*
- *Before attempting to unblock a segmented ball after it has become blocked (e.g. due to seizing up after remaining in the same position for a long time), release any energy (in the actuator) which causes the valve shaft to move.*

5.1 Installation conditions

Work position

The work position for the control valve is the front view looking onto the operating controls (including valve accessories).

Plant operators must ensure that, after installation of the device, the operating personnel can perform all necessary work safely and easily access the device from the work position.

Pipeline routing

The inlet and outlet lengths vary depending on several variables and process conditions and lie within the responsibility of the plant engineering company.

To ensure that the valve functions properly, proceed as follows:

- Install the valve free of stress and with the least amount of vibrations as possible. Read information under "Mounting position" and "Support or suspension" in this section.
- Install the valve allowing sufficient space to remove the actuator and valve or to perform service and repair work on them.

Mounting position

To ensure that the valve seat and segmented ball are correctly centered inside the valve, the control valve must be placed in the closed position before it is installed into the pipeline.

Installation

We recommend installing the valve with the valve shaft in the horizontal position into the pipeline.

If required, the valve can also be installed into the pipeline with the valve shaft in the vertical position and the actuator on top of the valve.

→ Contact SAMSON if the mounting position is not as specified above.

Support or suspension

i Note

The plant engineering company is responsible for selecting and implementing a suitable support or suspension of the installed control valve and the pipeline.

Depending on the valve version and mounting position, the valve, actuator and pipeline must be supported or suspended.

Valves, which are not installed with the valve shaft in the vertical position in the pipeline, must be supported or suspended.

Valve accessories

→ During connection of valve accessories, make sure that they are easily accessible and can be operated safely from the work position.

Vent plugs

Vent plugs are screwed into the exhaust air ports of pneumatic and electropneumatic devices. They ensure that any exhaust air that forms can be vented to the atmosphere (to avoid excess pressure in the device). Further-

more, the vent plugs allow air intake to prevent a vacuum from forming in the device.

→ Locate the vent plug on the opposite side to the work position of operating personnel.

5.2 Preparation for installation

Before installation, make sure the following conditions are met:

- The valve is clean.
- The valve and all valve accessories (including piping) are not damaged.
- The valve data on the nameplate (type designation, valve size, material, pressure rating and temperature range) match the plant conditions (size and pressure rating of the pipeline, medium temperature etc.). See the 'Markings on the device' section for nameplate details.
- The requested or required additional pipe fittings (see the 'Design and principle of operation' section > 'Additional fittings') have been installed or prepared as necessary before installing the valve.

Proceed as follows:

- Lay out the necessary material and tools to have them ready during installation work.
- Flush the pipelines.

i Note

The plant operator is responsible for cleaning the pipelines in the plant.

- For steam applications, dry the pipelines. Moisture will damage the inside of the valve.
- Check any mounted pressure gauges to make sure they function properly.
- When the valve and actuator are already assembled, check the tightening torques of the bolted joints (▶ AB 0100). Components may loosen during transport.

Legend for Fig. 5-1 and Fig. 5-2

1	Support shaft	12	Valve shaft	46	Retainer seal
2	Yoke	15	Packing gland	49	Spacer
3	Bottom flange	17	Bearing bushing	70	Retaining screw
4	Insulating section	18	Bearing bushing	80	Washer
5	Valve body	30	Retainer	88	O-ring seal
7	Segmented ball	35	Bushing	90	Gasket
10	Spring	40	Packing		

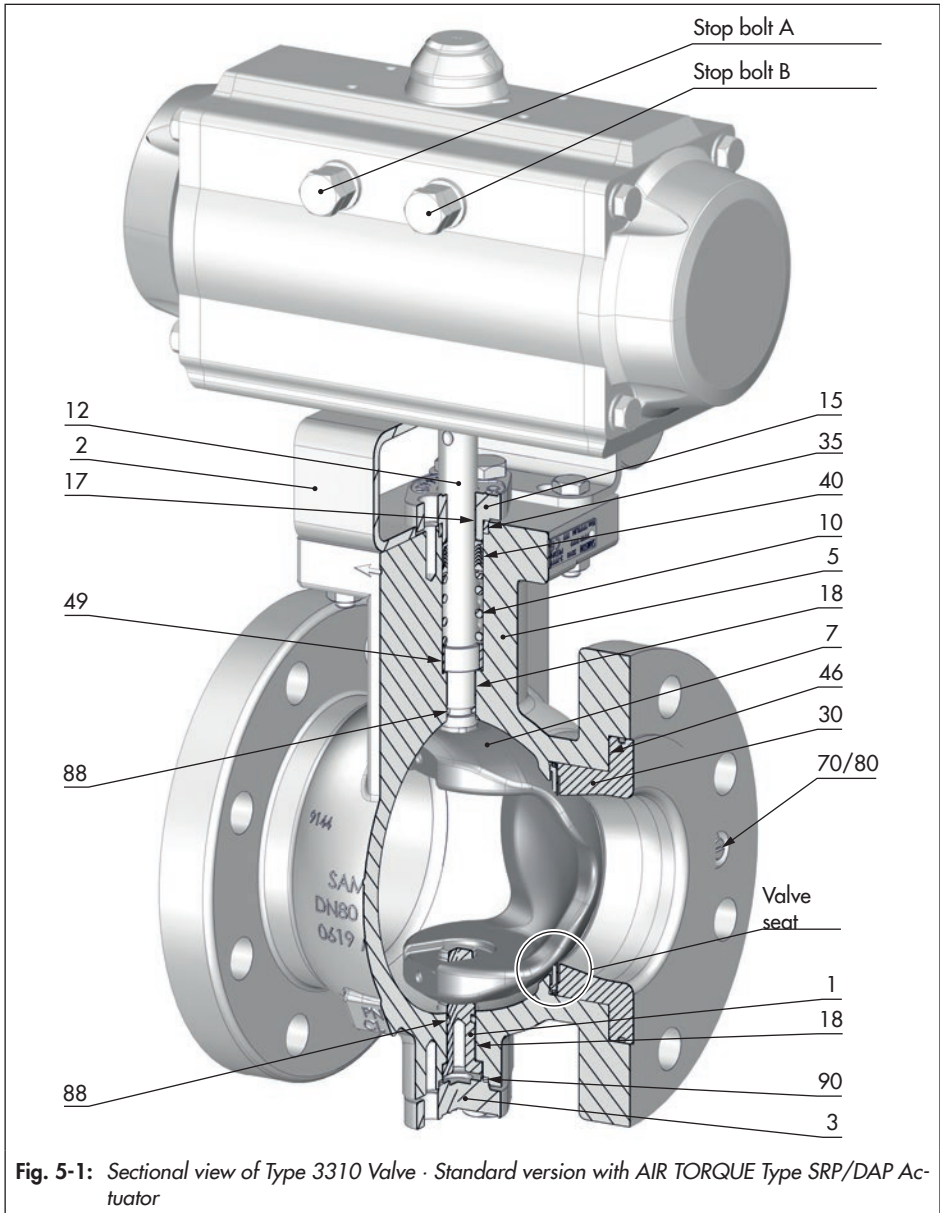

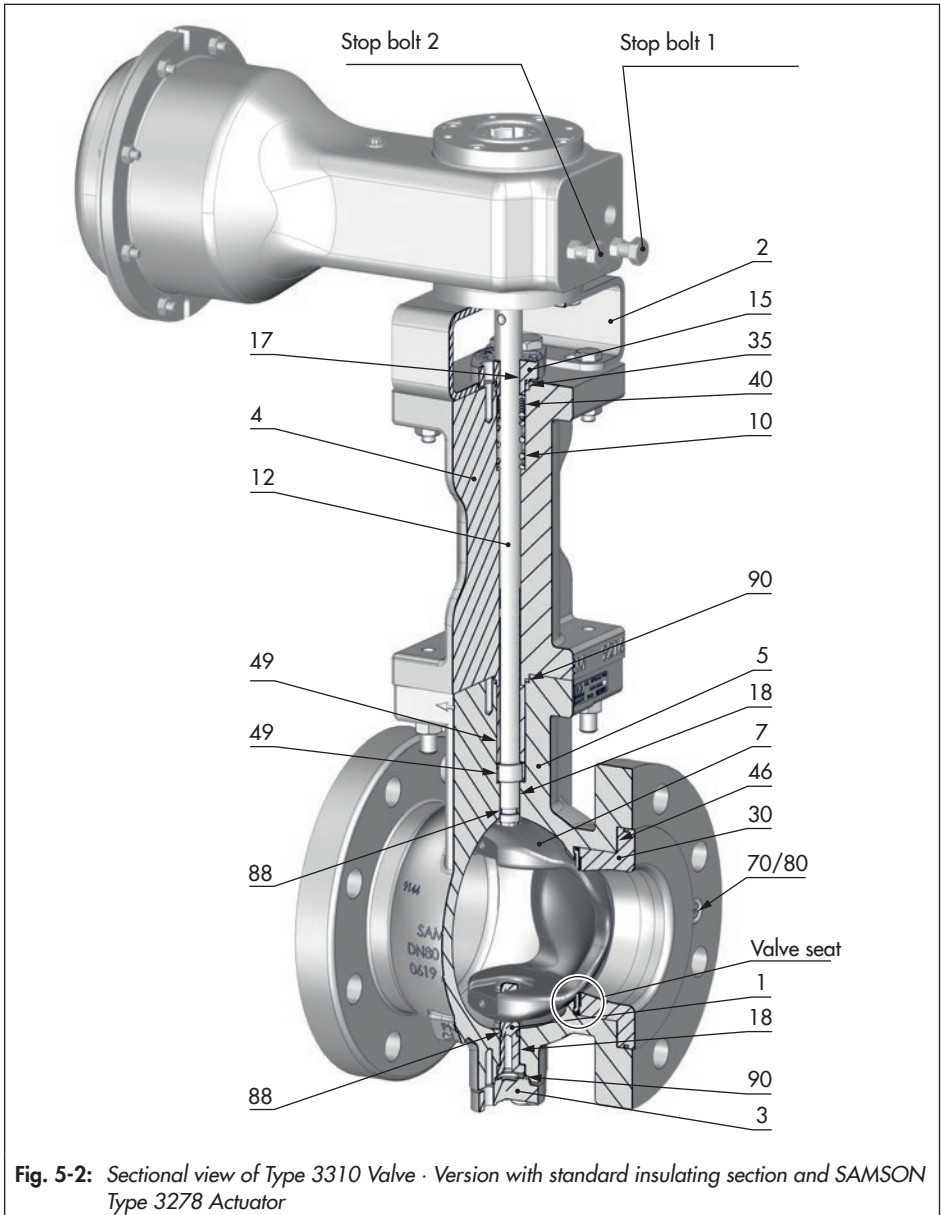

5.3 Mounting the device

The activities listed below are necessary to install the valve and before it can be started up.

! NOTICE

Risk of valve damage due to excessively high or low tightening torques.

Observe the specified torques when tightening control valve components. Excessive tightening torques lead to parts wearing out more quickly. Parts that are too loose may cause leakage.

→ Observe the specified tightening torques (▶ AB 0100).

! NOTICE

Risk of valve damage due to the use of unsuitable tools.

→ Only use tools approved by SAMSON (▶ AB 0100).

5.3.1 Mounting the actuator onto the valve

See Fig. 5-1 and Fig. 5-2

Depending on the version, SAMSON control valves are either delivered with the actuator already mounted on the valve or the valve and actuator are delivered separately. When delivered separately, the valve and actuator must be assembled together on site.

a) Type 3310 Valve with Type SRP Actuator

i Note

In the standard actuator version (SRP = single-acting with spring return mechanism), the spring return mechanism is designed to close clockwise when there is no signal pressure.

If you require a different direction of rotation or a double-acting actuator (DAP = double-acting without spring return mechanism), this specification must be submitted on ordering the actuator.

Table 5-1: Type 3310/SRP

Fail-safe position	Direction of rotation of the actuator shaft caused by the spring force
Fail-close	Clockwise
Fail-open	Counterclockwise

The square drive allows the actuator to be mounted on the segmented ball valve offset at angles of 90° in such a way that it is either mounted onto the segmented ball valve in the vertical or horizontal position to meet the installation requirements.

Fail-close

1. Place the segmented ball (7) of the valve in the CLOSED position (0° angle of rotation).
2. Fasten the yoke (2) to the flange of the valve shaft (12) using two or four screws (depending on the valve size).

3. If necessary, place the shaft adapter on the valve shaft (12). Slide the actuator over the adapter or valve shaft (12) and fasten it onto the yoke (2) with four screws. There must be no clearance between the actuator and valve shaft (12)/shaft adapter. If necessary, insert thin wedges (see Fig. 5-3 and the 'Accessories' section in the Annex).
4. For the actuator's standard direction of rotation, adjust the stop bolt B to the point where the valve is completely closed and align the markings on the valve shaft (12) and packing gland (15).
5. Lock the position of the stop bolt B with the lock nut.
6. Apply a signal pressure to the signal pressure connection which corresponds to the number of actuator springs (see actuator nameplate).
7. Turn the stop bolt A until the segmented ball stops at an opening angle of 90°.
8. Lock the position of the stop bolt A with the lock nut.

Fail-open

1. Place the segmented ball (7) of the valve in the OPEN position (90° angle of rotation).
2. Fasten the yoke (2) to the flange of the valve shaft (12) using two or four screws (depending on the valve size).
3. If necessary, place the shaft adapter on the valve shaft (12). Slide the actuator over the adapter or valve shaft (12) and fasten it onto the yoke (2) with four

screws. There must be no clearance between the actuator and valve shaft (12)/shaft adapter. If necessary, insert thin wedges (see Fig. 5-3 and the 'Accessories' section in the Annex).

4. For the actuator's standard direction of rotation, adjust the stop bolt A to the point where the valve is completely open at 90° and align the markings on the valve shaft (12) and packing gland (15).
5. Lock the position of the stop bolt A with the lock nut.
6. Apply a signal pressure to the signal pressure connection which corresponds to the number of actuator springs (see actuator nameplate).
7. Adjust the stop bolt B to the point where the segmented ball (7) completely closes the valve and align the markings on the valve shaft (12) and packing gland (15).
8. Lock the position of the stop bolt B with the lock nut.

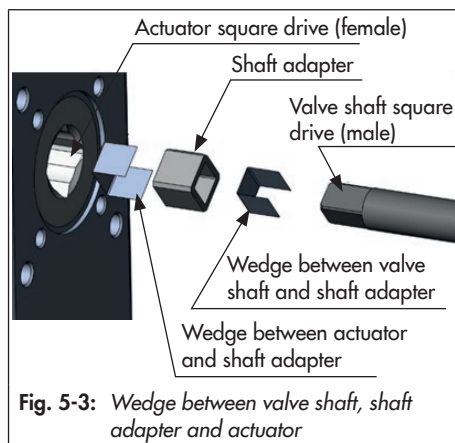

Fig. 5-3: *Wedge between valve shaft, shaft adapter and actuator*

b) Type 3310 Valve with Type 3278 Actuator

Mount the actuator onto the body flange 1 or 2 depending on the characteristic and fail-safe position.

'1' or '2' is cast on the corresponding side of the body.

Table 5-2: *Type 3310/3278*

Fail-safe position	Direction of rotation of the actuator shaft caused by the spring force	Body flange
Fail-close	Clockwise	2
Fail-open	Counterclockwise	1

The four feather key notches on the actuator shaft arranged every 90° allow the rotary actuator to be mounted on the segmented ball valve offset at angles of 90° in such a way that it is either in the vertical or horizontal position to meet the installation requirements.

Fail-close

1. Completely undo both stop bolts on the rotary actuator. Start to tighten the stop bolt 2 until the grooves of the actuator shaft are aligned with the actuator axis horizontally or vertically.
2. Place the segmented ball (7) of the valve in the CLOSED position (0° angle of rotation).
3. Fasten the yoke (2) to the flange of the valve shaft (12) using two or four screws (depending on the valve size).

4. Slide the actuator over the valve shaft (12) and fasten it onto the yoke (2) with four screws.
5. Undo the stop bolt 2 again.
6. Adjust the stop bolt 2 to the point where the valve is completely closed and align the markings on the valve shaft (12) and packing gland (15).
7. Apply a supply pressure required for the bench range (see actuator nameplate) to the loading pressure connection to open the valve.
8. Start to tighten the stop bolt 1 until the segmented ball (7) of the valve is in the OPEN position (90° angle of rotation).
9. Lock the position of both stop bolts with the lock nuts.

Fail-open

1. Completely undo both stop bolts on the rotary actuator. Start to tighten the stop bolt 1 until the grooves of the actuator shaft are aligned with the actuator axis horizontally or vertically.
2. Place the segmented ball (7) of the valve in the OPEN position (90° angle of rotation).
3. Fasten the yoke (2) to the flange of the valve shaft (12) using two or four screws (depending on the valve size).
4. Slide the actuator over the valve shaft (12) and fasten it onto the yoke (2) with four screws.
5. Undo the stop bolt 1 again.
6. Apply a supply pressure required for the bench range (see actuator nameplate) to

the loading pressure connection to close the valve.

7. Adjust the stop bolt 1 to the point where the segmented ball (7) completely closes the valve and align the markings on the valve shaft (12) and packing gland (15).
8. Disconnect the supply air from loading pressure connection.
9. Start to tighten the stop bolt 2 until the segmented ball (7) of the valve is in the OPEN position (90° angle of rotation).
10. Lock the position of both stop bolts with the lock nuts.

5.3.2 Installing the valve into the pipeline

Direction of flow

Observe the following concerning the direction of flow:

- Install the valve into the pipeline in such a way that the bottom half of the segmented ball opens in the direction of the flow.

This helps to prevent dirt deposits from accumulating and blocking the valve when it opens. The direction of medium flow into the ball also prevents the medium from collecting unnecessarily in the shaft bearings.

- The standard direction of flow (onto the convex side of the segmented ball) is indicated by an arrow on the valve (see the 'Markings on the device' section).
- The direction of flow can be reversed, e.g. for abrasive media. This direction of

flow causes the pressure of the process medium to constantly act on the packing. On tightening the flange bolts, make sure that an even pressure is exerted on the gaskets.

Installation

1. Close the shut-off valves in the pipeline at the inlet and outlet of the plant section while the valve is being installed.
2. Prepare the relevant section of the pipeline for installing the valve.
3. Remove the protective caps from the valve ports before installing the valve.
4. Place the segmented ball (7) of the valve in the CLOSED position. For valves combined with single-acting Type SRP and Type 3278 Rotary Actuators with fail-open action, the supply air must be connected to the actuator to close the valve.
5. Lift the valve using suitable lifting equipment to the site of installation (see the 'Shipment and on-site transport' section > 'Lifting the valve'). Observe the flow direction through the valve. The arrow on the valve indicates the direction of flow.
6. Make sure that the correct flange gaskets are used.
7. Bolt the pipe to the valve free of stress.

NOTICE

Risk of valve malfunction due to incorrect tightening torques.

The valve's functioning will be impaired if the bolt joints between the valve and pipeline are too tight.

Installation

- Observe the specified tightening torques (▶ AB 0100).

8. Attach a support or suspension on the valve, if necessary.

5.3.3 Signal pressure connection

- Connect the signal pressure to the signal pressure connection on the pneumatic actuator as described in the actuator documentation.

5.4 Testing the installed valve

⚠ DANGER

Risk of bursting due to incorrect opening of pressurized equipment or components.

Valves and pipelines are pressure equipment that may burst when handled incorrectly. Flying projectile fragments or the release of process medium under pressure can cause serious injury or even death.

Before working on the control valve:

- Depressurize all plant sections affected and the valve (including the actuator). Release any stored energy.
- Drain the process medium from all the plant sections concerned as well as the valve.

⚠ WARNING

Risk of hearing loss or deafness due to loud noise.

Noise emission (e.g. cavitation or flashing) may occur during operation caused by the process medium and the operating conditions. Additionally, a loud noise may briefly occur through the sudden venting of the pneumatic actuator or pneumatic valve accessories not fitted with noise-reducing fittings. Both can damage hearing.

- Wear hearing protection when working near the valve.

⚠ WARNING

Risk of personal injury due to exhaust air being vented from pneumatically operated components.

While the valve is operating, air is vented from the actuator, e.g. during closed-loop operation or when the valve opens or closes.

- Wear eye protection when working in close proximity to the control valve.

⚠ WARNING

Risk of personal injury due to preloaded springs.

Actuators with preloaded springs are under tension.

- Before starting any work on the actuator, relieve the compression from the preloaded springs (see associated actuator documentation).

To test the valve functioning before start-up or putting back the valve into operation, perform the following tests:

5.4.1 Leakage

The plant operator is responsible for performing the leak test and selecting the test method. The leak test must comply with the requirements of the national and international standards that apply at the site of installation.



Tip

Our after-sales service can support you to plan and perform a leak test for your plant.

1. Close the valve.
2. Slowly apply the test medium to the inlet space upstream of the valve. A sudden surge in pressure and resulting high flow velocities can damage the valve.
3. Open the valve.
4. Apply the required test pressure.
5. Check the valve for leakage to the atmosphere.
6. Depressurize the pipeline section and valve.
7. Rework any parts that leak and repeat the leak test.

5.4.2 Rotary motion

The rotary motion of the valve shaft must be even and smooth.

- Apply the maximum and minimum control signals to check the end positions of the valve while observing the movement of the valve shaft.

5.4.3 Fail-safe position

- Shut off the signal pressure line.
- Check whether the valve moves to the fail-safe position (see the 'Design and principle of operation' section).

5.4.4 Pressure test

The plant operator is responsible for performing the pressure test.



Tip

Our after-sales service can support you to plan and perform a pressure test for your plant.

During the pressure test, make sure the following conditions are met:

- Open the valve.
- Observe the maximum permissible pressure for both the valve and plant.

6 Start-up

The work described in this section is only to be performed by personnel appropriately qualified to carry out such tasks.

⚠ WARNING

Risk of burn injuries due to hot or cold components and pipeline.

Valve components and the pipeline may become very hot or cold. Risk of burn injuries.

- *Allow components and pipelines to cool down or warm up to the ambient temperature.*
- *Wear protective clothing and safety gloves.*

⚠ WARNING

Risk of hearing loss or deafness due to loud noise.

Noise emission (e.g. cavitation or flashing) may occur during operation caused by the process medium and the operating conditions. Additionally, a loud noise may briefly occur through the sudden venting of the pneumatic actuator or pneumatic valve accessories not fitted with noise-reducing fittings. Both can damage hearing.

- *Wear hearing protection when working near the valve.*

⚠ WARNING

Risk of personal injury due to exhaust air being vented from pneumatically operated components.

While the valve is operating, the actuator, for example, may vent during closed-loop operation or when the valve opens or closes.

- *Wear eye protection when working in close proximity to the control valve.*

Before start-up or putting the valve back into service, make sure the following conditions are met:

- The valve is properly installed into the pipeline (see the 'Installation' section).
- The leak and function tests have been completed successfully (see the 'Installation' section > 'Testing the installed valve').
- The prevailing conditions in the plant section concerned meet the valve sizing requirements (see information under 'Intended use' in the 'Safety instructions and measures' section).

Start-up

Start-up/putting the device back into operation

1. Allow the valve to cool down or warm up to reach ambient temperature before start-up when the ambient temperature and process medium temperature differ greatly or the medium properties require such a measure.
2. Slowly open the shut-off valves in the pipeline. Slowly opening these valves prevents a sudden surge in pressure and high flow velocities which can damage the valve.
3. Check the valve to ensure it functions properly.

7 Operation

Immediately after completing start-up or putting the valve back into operation, the valve is ready for use.

⚠ WARNING

Risk of burn injuries due to hot or cold components and pipeline.

Valve components and the pipeline may become very hot or cold. Risk of burn injuries.

- Allow components and pipelines to cool down or warm up to the ambient temperature.
- Wear protective clothing and safety gloves.

⚠ WARNING

Risk of hearing loss or deafness due to loud noise.

Noise emission (e.g. cavitation or flashing) may occur during operation caused by the process medium and the operating conditions. Additionally, a loud noise may briefly occur through the sudden venting of the pneumatic actuator or pneumatic valve accessories not fitted with noise-reducing fittings. Both can damage hearing.

- Wear hearing protection when working near the valve.

⚠ WARNING

Risk of personal injury due to exhaust air being vented from pneumatically operated components.

While the valve is operating, the actuator, for example, may vent during closed-loop operation or when the valve opens or closes.

- Wear eye protection when working in close proximity to the control valve.

7.1 Normal operation

The handwheel of valves with actuators fitted with an additional handwheel must be in the neutral position during normal operation.

7.2 Manual operation

Valves with actuators fitted with a handwheel can be manually closed or opened in case of supply air failure.

8 Malfunctions

Read hazard statements, warnings and caution notes in the 'Safety instructions and measures' section.

8.1 Troubleshooting

Malfunction	Possible reasons	Recommended action
Valve shaft does not move on demand.	Initial breakaway torque too high	Shut off the section of the pipeline and flush the valve to remove any deposits (dirt or other foreign particles). Depressurize valve and actuator. Use a cloth to clean the segmented ball and seat ring.
		Contact our after-sales service when bearings are defective or have dirt deposits on them.
		Contact our after-sales service when the segmented ball is not correctly centered.
		Tighten the fastening screws of the retainer using the specified torque.
	See 'Servicing and conversion' section > 'Replacing the seat ring' > 'Final work'.	
	The segmented ball is blocked.	Remove the blockage. WARNING! A blocked segmented ball can suddenly start to rotate during activities to unblock it. This can lead to crush injuries to hands or fingers if they are inserted into the valve. Before attempting to unblock the segmented ball, release any energy (in the actuator) which causes the valve shaft to move (e.g. also the spring compression). Disconnect and lock the pneumatic air supply as well as the control signal.
	Diaphragm in the actuator defective	See associated actuator documentation.
	Signal pressure too low	Check the signal pressure. Check the signal pressure line for leakage.
	Incorrect setting of valve accessories	Check the settings of the valve accessories.

Malfunctions

Malfunction	Possible reasons	Recommended action
Increased flow through closed valve (seat leakage). The leakage class specification cannot be met.	Dirt or other foreign particle deposits have collected inside the valve.	Shut off the section of the pipeline and flush the valve. Depressurize valve and actuator. Use a cloth to clean the segmented ball and seat ring.
	Clearance (play) in the connection between the actuator and valve shaft/ shaft adapter.	Shaft end with square drive: insert thin wedges.
		Shaft end with key drive: replace feather key.
	Incorrect setting of stop bolts	Readjust stop bolts (see the 'Installation' section > 'Mounting the actuator onto the valve').
	Markings on the actuator shaft and packing gland not aligned with each other	Align the markings. They indicate the best closed position of the valve.
	Segmented ball not correctly centered	Contact our after-sales service.
	Seat ring worn out	Replace seat ring (see 'Servicing and conversion' section > 'Replacing the seat ring').
Segmented ball worn out	Contact our after-sales service.	
The valve leaks to the atmosphere (fugitive emissions).	Defective packing	Replace packing (see 'Servicing and conversion' section > 'Replacing the packing').
	Flanged joint loose or gasket defective	Check the flanged joint. Put the control valve out of operation (see the 'Decommissioning' section) and renew the gasket at the flanged joint.
	Retainer seal on the retainer defective	Replace retainer seal (see 'Servicing and conversion' section > 'Replacing the seat ring').
	Gasket on the bottom flange defective	Put the control valve out of operation (see the 'Decommissioning' section) and renew the gasket between the bottom flange and valve body.
	Version with insulating section: gasket between valve body and insulating section defective	Put the control valve out of operation (see the 'Decommissioning' section) and renew the gasket between the valve body and insulating section.
Flow rates do not meet the specifications	Wrong characteristic	See 'Servicing and conversion' section > 'Changing the characteristic'.

i Note

Contact our after-sales service for malfunctions not listed in the table.

8.2 Emergency action

Plant operators are responsible for emergency action to be taken in the plant.

In the event of a valve malfunction:

1. Close the shut-off valves upstream and downstream of the control valve to stop the process medium from flowing through the valve.
2. Perform troubleshooting (see section 8.1).
3. Rectify those malfunctions that can be remedied based on the instructions provided here. Contact our after-sales service in all other cases.

Putting the device back into operation after a malfunction

See the 'Start-up' section.

9 Servicing and conversion

The work described in this section is to be performed only by personnel appropriately qualified to carry out such tasks.

The following documents are also required for servicing the valve:

- Mounting and operating instructions for the mounted actuator, e.g. ► EB 8321 for the SAMSON Type 3278 Pneumatic Rotary Actuator
- ► AB 0100 for tools, tightening torques and lubricant

⚠ DANGER

Risk of bursting due to incorrect opening of pressurized equipment or components.

Valves and pipelines are pressure equipment that may burst when handled incorrectly. Flying projectile fragments or the release of process medium under pressure can cause serious injury or even death.

Before working on the control valve:

- ➔ Depressurize all plant sections affected and the valve (including the actuator). Release any stored energy.
- ➔ Drain the process medium from all the plant sections concerned as well as the valve.

⚠ WARNING

Risk of burn injuries due to hot or cold components and pipeline.

Valve components and the pipeline may become very hot or cold. Risk of burn injuries.

- ➔ Allow components and pipelines to cool down or warm up to the ambient temperature.
- ➔ Wear protective clothing and safety gloves.

⚠ WARNING

Risk of hearing loss or deafness due to loud noise.

Noise emission (e.g. cavitation or flashing) may occur during operation caused by the process medium and the operating conditions. Additionally, a loud noise may briefly occur through the sudden venting of the pneumatic actuator or pneumatic valve accessories not fitted with noise-reducing fittings. Both can damage hearing.

- ➔ Wear hearing protection when working near the valve.

⚠ WARNING

Crush hazard arising from moving parts.

The valve's segmented ball turns in the valve body which can lead to crush injuries to hands or fingers if they are inserted into the valve.

- ➔ Do not insert hands or fingers into the valve body.
- ➔ Before working on the control valve, release any energy (in the actuator) which causes the valve shaft to move (e.g. also the spring compression).
- ➔ Before working on the control valve, disconnect and lock the pneumatic air supply as well as the control signal.

Servicing and conversion

- Disconnect the supply voltage before performing any work on the control valve.
- Do not impede the rotary motion of the segmented ball by inserting objects into its path.
- Before attempting to unblock a segmented ball after it has become blocked (e.g. due to seizing up after remaining in the same position for a long time), release any energy (in the actuator) which causes the valve shaft to move.

⚠ WARNING

Risk of personal injury due to exhaust air being vented from pneumatically operated components.

While the valve is operating, air is vented from the actuator, e.g. during closed-loop operation or when the valve opens or closes.

- Wear eye protection when working in close proximity to the control valve.

⚠ WARNING

Risk of personal injury due to preloaded springs.

Actuators with preloaded springs are under tension.

- Before starting any work on the actuator, relieve the compression from the preloaded springs (see associated actuator documentation).

⚠ WARNING

Risk of personal injury due to residual process medium in the valve.

While working on the valve, residual medium can flow out of the valve and, depending on its properties, cause personal injury, e.g. (chemical) burns.

- Wear protective clothing, safety gloves and eye protection.

ⓘ NOTICE

Risk of valve damage due to excessively high or low tightening torques.

Observe the specified torques when tightening control valve components. Excessive tightening torques lead to parts wearing out more quickly. Parts that are too loose may cause leakage.

- Observe the specified tightening torques (▶ AB 0100).

ⓘ NOTICE

Risk of valve damage due to the use of unsuitable tools.

- Only use tools approved by SAMSON (▶ AB 0100).

ⓘ NOTICE

Risk of valve damage due to the use of unsuitable lubricants.

- Only use lubricants approved by SAMSON (▶ AB 0100).

i Note

The control valve was checked by SAMSON before delivery.

- Certain test results certified by SAMSON lose their validity when the valve is opened. Such testing includes seat leakage and leak tests.
- The product warranty becomes void if service or repair work not described in these instructions is performed without prior agreement by SAMSON's After-sales Service.
- Only use original spare parts by SAMSON, which comply with the original specifications.

9.1 Periodic testing

Depending on the operating conditions, check the valve at certain intervals to prevent possible failure before it can occur. Plant operators are responsible for drawing up an inspection and test plan.

💡 Tip

Our after-sales service can support you in drawing up an inspection and test plan for your plant.

9.2 Preparation for servicing or conversion work

1. Lay out the necessary material and tools to have them ready for the intended work.

2. Put the control valve out of operation (see the 'Decommissioning' section).
3. Remove the actuator from the valve. See associated actuator documentation.
4. Remove the valve from the pipeline before performing any service work (see the 'Removal' section).

The following service work can be performed after preparation is completed:

- Replace the packing (see section 9.5.1)
- Replace the seat ring (see section 9.5.2)

9.3 Mounting the actuator on the valve after service or conversion work

1. Mount actuator. See associated actuator documentation and the 'Installation' section.
2. Adjust lower or upper signal bench range. See associated actuator documentation.
3. If the valve has been removed, re-install the valve into the pipeline (see the 'Installation' section).
4. Put the control valve back into operation (see the 'Start-up' section). Observe the requirements and conditions for start-up or putting the valve back into operation.

9.4 Conversion work

9.4.1 Changing the fail-safe action

a) Type 3278 Pneumatic Rotary Actuator

The fail-safe action of SAMSON Type 3278 Actuator can be changed from fail-close to fail-open or vice versa after the valve has been installed. In this case, the side where the rotary actuator is mounted must be changed (see the 'Installation' section > 'Mounting the actuator onto the valve').

→ Proceed as described in the associated actuator documentation (▶ EB 8321).

b) Single-acting Type SRP and Pneumatic Rotary Actuator

To change the fail-safe action of single-acting AIR TORQUE Type SRP Actuator from fail-close to fail-open or vice versa after the valve has been installed, the pistons in the actuator must be changed.

→ Proceed as described in the associated actuator documentation.

c) Double-acting Type DAP Pneumatic Rotary Actuator

The double-acting AIR TORQUE Type DAP Rotary Actuator does not move to a defined end position when the supply air fails. In this case, conversion to change the fail-safe action does not apply.

i Note

Refer to the mounting and operating instructions of the rotary actuator used for further details, for example about changing the spring range to achieve other actuator torques.

9.4.2 Changing the characteristic

Changing the characteristic from equal percentage to linear and vice versa can be performed by turning the segmented ball on the pipeline axis by 180° or by changing the actuator's direction of rotation.

→ Contact our after-sales service to turn the segmented ball.

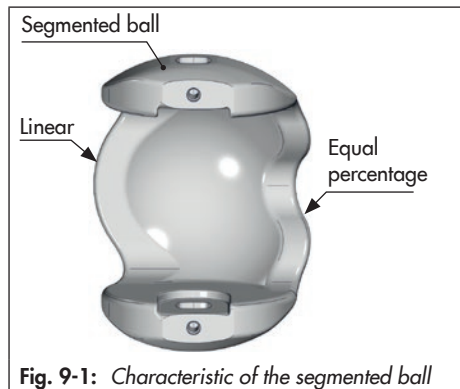

Fig. 9-1: Characteristic of the segmented ball

9.5 Service work

- Before performing any service work, preparations must be made to the control valve (see section 9.2).
- After all service work is completed, check the control valve before putting it back into operation (see the 'Installation' section > 'Testing the installed valve').

9.5.1 Replacing the packing

See Fig. 9-2 and Fig. 9-3

The segmented ball valves are fitted with a packing to seal the valve shaft.

a) Standard version

1. Undo the bolted connection (60 or 65, 75). Lift off the packing gland (15) and the bearing bushing (17).
2. Clean the packing gland (15) and the bearing bushing (17). Apply lubricant to the inside diameter of the packing gland

(15) and insert the bearing bushing (17) from below into the packing gland.

3. Pull the entire packing parts (35, 40, 20, 10, 24, 49) out of the packing chamber using a suitable tool.
4. Clean the packing chamber thoroughly.
5. Apply lubricant to each V-ring before adding it to the new packing (40).
6. Apply lubricant to the inside and outside diameters of the packing (40).
7. Push the ring (35) over the valve shaft (12) into the valve body. Make sure the proper alignment is achieved by paying attention to the beveled part (see Fig. 9-3).
8. Mount the spacer (49) in such a way that it covers the shoulder of the valve shaft (12). Make sure the proper alignment is achieved by paying attention to the beveled part (see Fig. 9-3).
9. Slide the first sliding washer (24), spring (10) and the second washer (20) into the packing chamber.

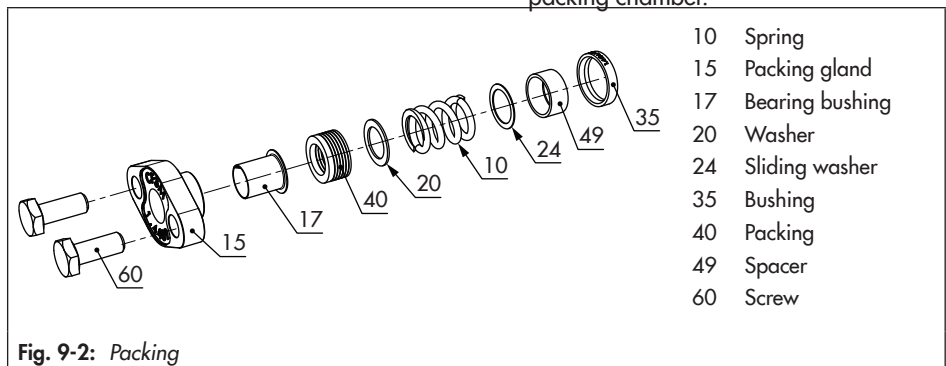

Fig. 9-2: Packing

Servicing and conversion

10. Push the packing (40) into the packing chamber. Make sure the V-rings are properly aligned (see Fig. 9-3).
11. Lubricate the screw connection (60 or 65, 75) and use it to fasten the packing gland (15) including the bearing bushing (17) onto the valve body. Observe tightening torques.

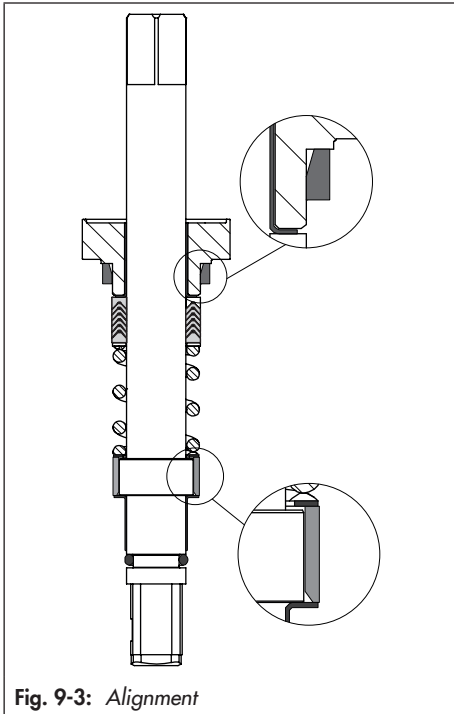

Fig. 9-3: Alignment

Preparation work for all versions

1. Unscrew both retaining screws (70) and remove them together with the washers (80).
2. Remove the retainer (30) with retainer seal (46).
If you are unable to remove the retainer, use the special tool (▶ AB 0100).

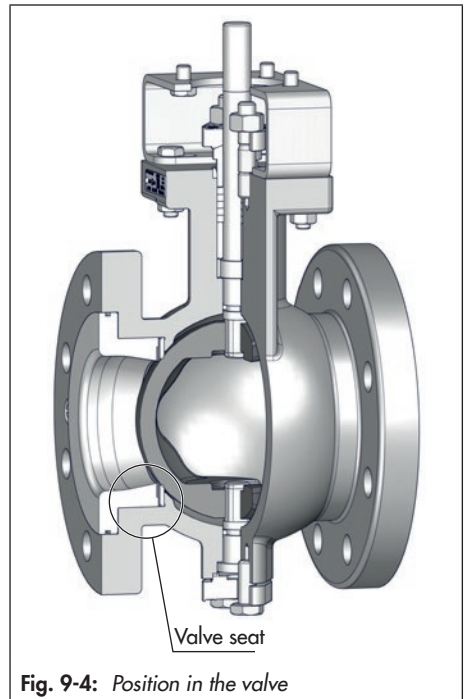

Fig. 9-4: Position in the valve

9.5.2 Replacing the seat ring

See sectional views in the 'Design and principle of operation' section and Fig. 9-4.

a) Soft-seated PTFE version (S)

See Fig. 9-5

1. Remove the support ring (25) and seat ring (21).
2. Check surfaces and facings to ensure they are not damaged. If they are damaged, interrupt the service work and contact our after-sales service.
3. Move the segmented ball to the closed position.
4. Insert a new seat (21) into the body.
5. Insert the support ring (25). Make sure it is properly aligned (see Fig. 9-5).
6. Mount the retainer seal (46) on the retainer (30).

7. Insert the retainer (30) with retainer seal (46) into the valve body and fasten using retaining screws (70) and washers (80). Observe tightening torques.

 **Tip**

The retainer (30) can be pressed into the body using, for example, a blank flange, by tightening the flange bolts accordingly. In this case, first place the valve in the CLOSED position to center the seat ring and segmented ball.

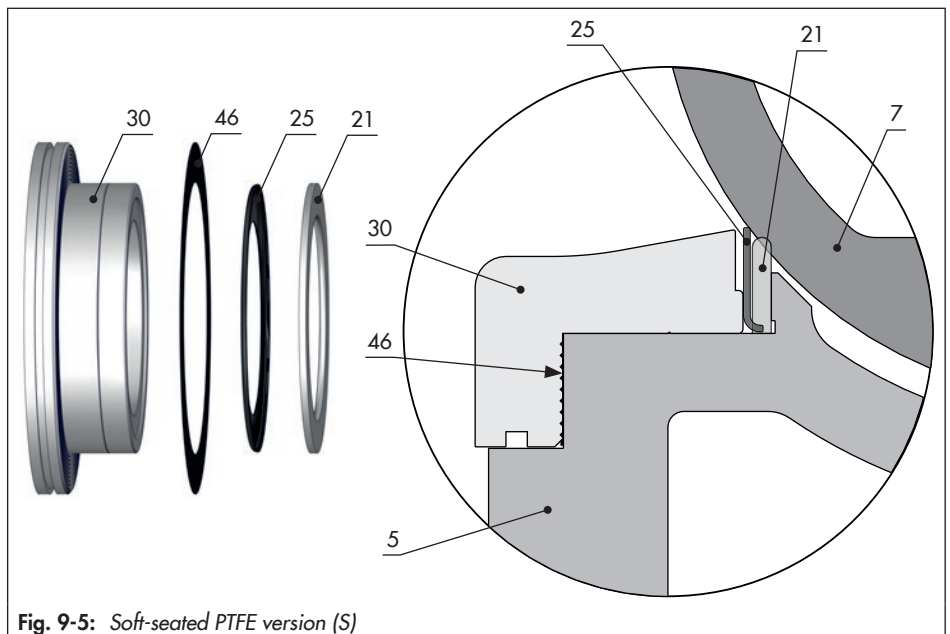

Fig. 9-5: Soft-seated PTFE version (S)

b) Soft-seated PEEK version (S)

See Fig. 9-6

1. Remove the support ring (25) and seat ring (21).
2. Check surfaces and facings to ensure they are not damaged. If they are damaged, interrupt the service work and contact our after-sales service.
3. Move the segmented ball to the closed position.
4. Insert a new seat (21) into the body. Make sure it is properly aligned (see Fig. 9-6).
5. Insert the support ring (25). Make sure it is properly aligned (see Fig. 9-6).
6. Mount the retainer seal (46) on the retainer (30).
7. Insert the retainer (30) with retainer seal (46) into the valve body (see "Tip" on page 9-7) and fasten using retaining screws (70) and washers (80). Observe tightening torques.

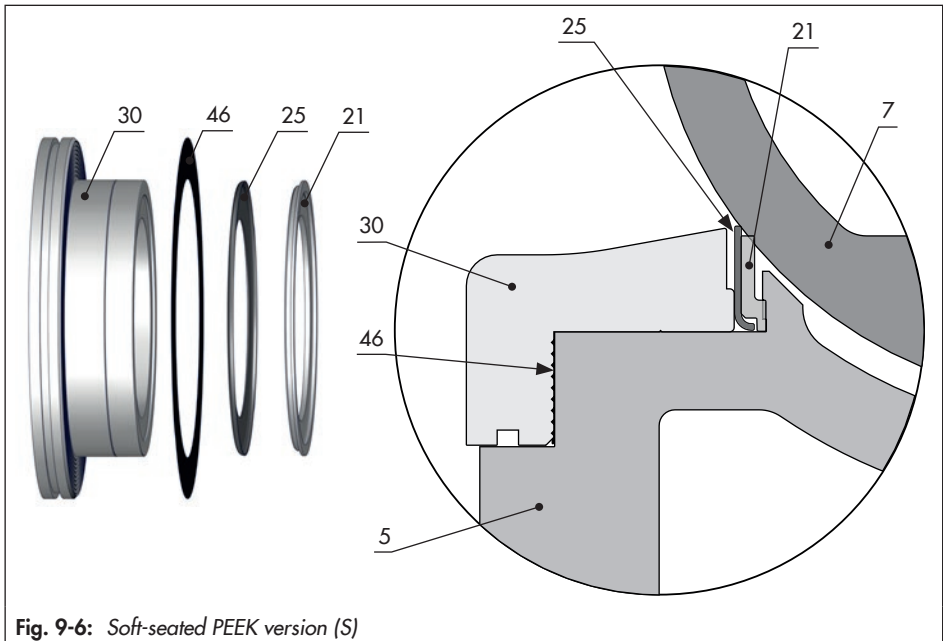

Fig. 9-6: Soft-seated PEEK version (S)

c) ARCAP® metal-seated version (A)

screws (70) and washers (80). Observe tightening torques.

See Fig. 9-7

1. Remove in sequence any washer(s) (23), metal O-ring (26) and seat ring (21).
2. Check the marking on the packing gland (15) for the distribution of washers (23).
If no marking exists, note how the washers are distributed to be able to remount them correctly afterwards.
3. Check surfaces and facings to ensure they are not damaged. If they are damaged, interrupt the service work and contact our after-sales service.
4. Move the segmented ball to the closed position.
5. Insert washer(s) (23) one after the other (see step 2).

The position of the washers (23) may vary between position A and B (see Fig. 9-7). The position depends on the leakage rate and initial breakaway torque (see information under b), "ARCAP® metal-seated version (A)" on page 9-12.

6. Insert a new seat (21) into the body. Make sure it is properly aligned (see Fig. 9-7).
7. Insert the metal O-ring (26).
8. Mount the retainer seal (46) on the retainer (30).
9. Insert the retainer (30) with retainer seal (46) into the valve body (see "Tip" on page 9-7) and fasten using retaining

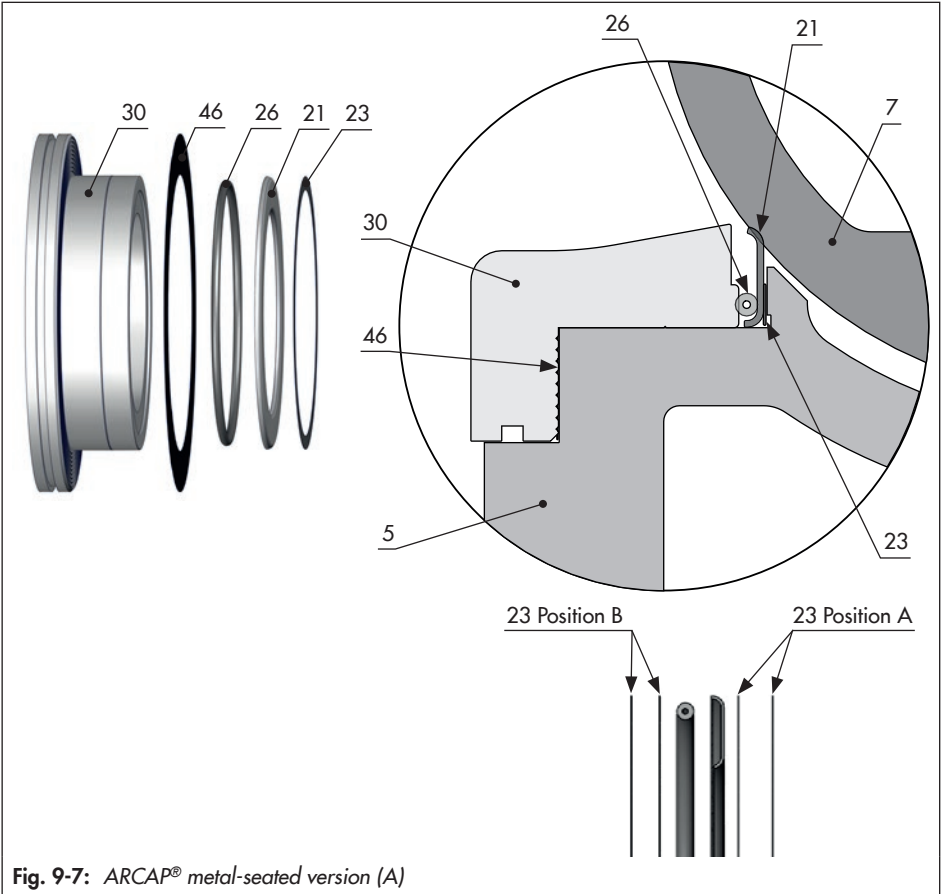

d) Enhanced metal-seated version (E)

See Fig. 9-8

1. Remove the seat ring (21) and spring-loaded gasket (27).
2. Check surfaces and facings to ensure they are not damaged. If they are damaged, interrupt the service work and contact our after-sales service.
3. Apply lubricant to the surfaces of the retainer (30), on which the spring-loaded gasket rests, and on the facings of the seat ring (21).
4. Insert the spring-loaded gasket (27) into the retainer (30).
5. Insert the new seat ring (21) into the retainer (30).
6. Move the segmented ball to the closed position.
7. Mount the retainer seal (46) on the retainer (30).
8. Insert the ready-assembled retainer (30) into the valve body (see "Tip" on page 9-7) and fasten using retaining screws (70) and washers (80). Observe tightening torques.

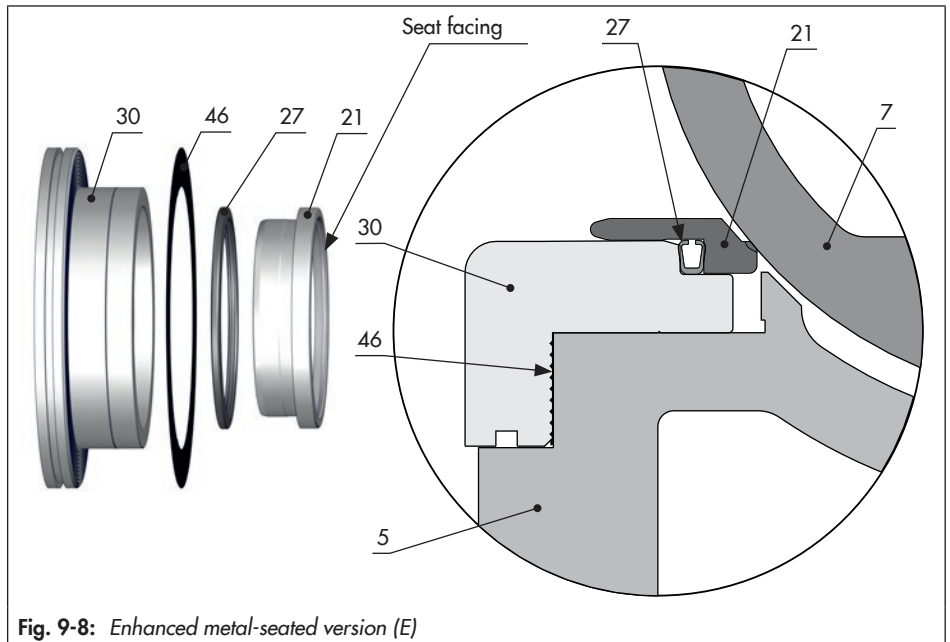

Fig. 9-8: Enhanced metal-seated version (E)

Final work

a) Versions with PTFE soft seal (S), PEEK soft seal (S) and Enhanced metal seal (E)

The seat ring must be slightly pushed further inwards. To do this, open and close the segmented ball with equal percentage side (%) two or three times.

b) ARCAP® metal-seated version (A)

See Fig. 9-7

- If the initial breakaway torque required to open the valve is too high, the washers (23) in position B (between the metal O-ring and retainer) press with too much force against the segmented ball. In this case, change the position of the washers (23) from position B to A (at the seat in the valve body).
- If the seat leakage is too high, the washers (23) on the seat in the valve body (position A) are not pressing with sufficient force against the segmented ball. In this case, change the position of the washers (23) from position A (at the seat in the valve body) to position B (between the metal O-ring and retainer).

9.5.3 Replacing the segmented ball, valve shaft and bearings

NOTICE

Risk of control valve damage due to incorrect servicing.

- To replace segmented ball, valve shaft and bearings, contact our after-sales service.
-

9.6 Ordering spare parts and operating supplies

Contact your nearest SAMSON subsidiary or SAMSON's After-sales Service for information on spare parts, lubricants and tools.

Spare parts

See Annex for details on spare parts.

Lubricant

See document ► AB 0100 for details on suitable lubricants.

Tools

See document ► AB 0100 for details on suitable tools.

10 Decommissioning

The work described in this section is only to be performed by personnel appropriately qualified to carry out such tasks.

⚠ DANGER

Risk of bursting due to incorrect opening of pressurized equipment or components.

Valves and pipelines are pressure equipment that may burst when handled incorrectly.

Flying projectile fragments or the release of process medium under pressure can cause serious injury or even death.

Before working on the control valve:

- Depressurize all plant sections affected and the valve (including the actuator). Release any stored energy.
- Drain the process medium from all the plant sections concerned as well as the valve.

⚠ WARNING

Risk of burn injuries due to hot or cold components and pipeline.

Valve components and the pipeline may become very hot or cold. Risk of burn injuries.

- Allow components and pipelines to cool down or warm up to the ambient temperature.
- Wear protective clothing and safety gloves.

⚠ WARNING

Risk of hearing loss or deafness due to loud noise.

Noise emission (e.g. cavitation or flashing) may occur during operation caused by the process medium and the operating conditions. Additionally, a loud noise may briefly occur through the sudden venting of the pneumatic actuator or pneumatic valve accessories not fitted with noise-reducing fittings. Both can damage hearing.

- Wear hearing protection when working near the valve.

⚠ WARNING

Crush hazard arising from moving parts.

The valve's segmented ball turns in the valve body which can lead to crush injuries to hands or fingers if they are inserted into the valve.

- Do not insert hands or fingers into the valve body.
- Before working on the control valve, release any energy (in the actuator) which causes the valve shaft to move (e.g. also the spring compression).
- Before working on the control valve, disconnect and lock the pneumatic air supply as well as the control signal.
- Disconnect the supply voltage before performing any work on the control valve.
- Do not impede the rotary motion of the segmented ball by inserting objects into its path.

Decommissioning

→ Before attempting to unblock a segmented ball after it has become blocked (e.g. due to seizing up after remaining in the same position for a long time), release any energy (in the actuator) which causes the valve shaft to move.

WARNING

Risk of personal injury due to exhaust air being vented from pneumatically operated components.

While the valve is operating, the actuator, for example, may vent during closed-loop operation or when the valve opens or closes.

→ Wear eye protection when working in close proximity to the control valve.

WARNING

Risk of personal injury due to residual process medium in the valve.

While working on the valve, residual medium can flow out of the valve and, depending on its properties, cause personal injury, e.g. (chemical) burns.

→ Wear protective clothing, safety gloves and eye protection.

To decommission the control valve for service work or to remove it from the pipeline, proceed as follows:

1. Close the shut-off valves upstream and downstream of the control valve to stop the process medium from flowing through the valve.
2. Completely drain the pipelines and valve.
3. Disconnect and lock the pneumatic air supply to depressurize the actuator.
4. Release any stored energy.
5. If necessary, allow the pipeline and valve components to cool down or warm up to the ambient temperature.

11 Removal

The work described in this section is only to be performed by personnel appropriately qualified to carry out such tasks.

⚠ WARNING

Risk of burn injuries due to hot or cold components and pipeline.

Valve components and the pipeline may become very hot or cold. Risk of burn injuries.

- Allow components and pipelines to cool down or warm up to the ambient temperature.
- Wear protective clothing and safety gloves.

⚠ WARNING

Crush hazard arising from moving parts.

The valve's segmented ball turns in the valve body which can lead to crush injuries to hands or fingers if they are inserted into the valve.

- Do not insert hands or fingers into the valve body.
- Before working on the control valve, release any energy (in the actuator) which causes the valve shaft to move (e.g. also the spring compression).
- Before working on the control valve, disconnect and lock the pneumatic air supply as well as the control signal.
- Disconnect the supply voltage before performing any work on the control valve.

- Do not impede the rotary motion of the segmented ball by inserting objects into its path.
- Before attempting to unblock a segmented ball after it has become blocked (e.g. due to seizing up after remaining in the same position for a long time), release any energy (in the actuator) which causes the valve shaft to move.

⚠ WARNING

Risk of personal injury due to residual process medium in the valve.

While working on the valve, residual medium can flow out of the valve and, depending on its properties, cause personal injury, e.g. (chemical) burns.

- Wear protective clothing, safety gloves and eye protection.

⚠ WARNING

Risk of personal injury due to preloaded springs.

Actuators with preloaded springs are under tension. They can be identified by the long bolts protruding from the bottom of the actuator.

- Before starting any work on the actuator, relieve the compression from the preloaded springs.

Before removing the valve, make sure the following conditions are met:

- The control valve is put out of operation (see the 'Decommissioning' section).

Removal

11.1 Removing the valve from the pipeline

1. Support the valve to hold it in place when separated from the pipeline (see the 'Shipment and on-site transport' section).
2. Unbolt the flange joint.
3. Remove the valve from the pipeline (see the 'Shipment and on-site transport' section).

11.2 Removing the actuator from the valve

See associated actuator documentation.

12 Repairs

If the valve does not function properly according to how it was originally sized or does not function at all, it is defective and must be repaired or exchanged.

! NOTICE

Risk of valve damage due to incorrect repair work.

- Do not perform any repair work on your own.
- Contact SAMSON's After-sales Service for repair work.

12.1 Returning devices to SAMSON

Defective devices can be returned to SAMSON for repair.

Proceed as follows to return devices:

1. Exceptions apply concerning some special device models
 - ▶ www.samsongroup.com > Service & Support > After-sales Service.
2. Send an e-mail ▶ retouren@samsongroup.com to register the return shipment including the following information:
 - Type
 - Article no.
 - Configuration ID
 - Original order

- Completed Declaration on Contamination, which can be downloaded from our website at
 - ▶ www.samsongroup.com > Service & Support > After-sales Service.

After checking your registration, we will send you a return merchandise authorization (RMA).

3. Attach the RMA (together with the Declaration on Decontamination) to the outside of your shipment so that the documents are clearly visible.
4. Send the shipment to the address given on the RMA.

i Note

Further information on returned devices and how they are handled can be found at

- ▶ www.samsongroup.com > Service & Support > After-sales Service.

13 Disposal



SAMSON is a producer registered at the following European institution
 ► <https://www.ewrn.org/national-registers/national-registers>.
 WEEE reg. no.: DE 62194439/
 FR 02566

- ➔ Observe local, national and international refuse regulations.
- ➔ Do not dispose of components, lubricants and hazardous substances together with your household waste.

i Note

We can provide you with a recycling passport according to PAS 1049¹⁾ on request. Simply e-mail us at offersaleservice@samsongroup.com giving details of your company address.

Tip

On request, we can appoint a service provider to dismantle and recycle the product as part of a distributor take-back scheme.

¹⁾ PAS 1049 is relevant to electrical and electronic equipment (e.g. electric actuators). This PAS specification does not apply to non-electrical equipment.

14 Certificates

The following declarations are included on the next pages:

- Declaration of conformity in compliance with Pressure Equipment Directive 2014/68/EU on pages 14-2 to 14-5
- Declaration of conformity according to Machinery Directive 2006/42/EC on page 14-6
- Declaration of incorporation in compliance with Machinery Directive 2006/42/EC for Type 3310 Valve on page 14-7
- Declaration of conformity in compliance with the 2016 Regulations No. 1105 Pressure Equipment (Safety) Regulations 2016, see pages 14-8 to 14-11
- Declaration of conformity in compliance with the 2008 Regulations No. 1597 Supply of Machinery (Safety) Regulations 2008:
 - Final machinery, see page 14-12
 - Partly completed machinery, see page 14-13
- Declaration of conformity in compliance with the requirements in TSG D7002-2006 for Chinese pressure equipment on page 14-14
- Declaration of conformity according to Regulation China RoHS 2.0, GB/T26572-2011 on page 14-15
- RoHS declaration of conformity in compliance with Directive 2011/65/EU, 2015/863/EU on page 14-16

- REACH declaration of conformity in compliance with the EU Regulation (EC) No. 1907/2006 on pages 14-17 to 14-18

The following declarations only apply to valves that have been specifically ordered to meet such requirements.

- Declaration of conformity for valve with gaskets and packings that comply with the EU Regulation (EC) No. 1935/2004 and the US Regulation FDA 21 CFR Section 177.1550. See page 14-19
- Declaration of conformity for valve for cleanroom environments: materials (gaskets, packings, body), manufacture of parts as well as assembly conditions in accordance with the EU Regulation (EC) No. 1935/2004 and the US Regulation FDA 21 CFR Section 177.1550. See page 14-20

The certificates shown were up to date at the time of publishing. The latest certificates can be found on our website:

▶ www.samsongroup.com > *Products & Applications* > *Product selector* > *Valves* > 3310

Other optional certificates are available on request.



DECLARATION UE DE CONFORMITE EU DECLARATION OF CONFORMITY

1/2

Module A / Modul A

**DC014
2022-05**

Par la présente, SAMSON REGULATION SAS déclare sous sa seule responsabilité pour les produits suivants :
For the following products, SAMSON REGULATION SAS hereby declares under its sole responsibility:

Appareils / Devices	Type	Exécution / Version	Matériel du corps / body Material	PN Class	DN NPS	Fluides / fluids
Vanne de décharge / Back pressure reducing valve	2371-0	DIN	Acier / steel	$P_{max} T = 20^{\circ}C$ 10 bar	DN 32 – 50	Tous fluides / all fluids
		ANSI		$P_{max} T = 70^{\circ}F$ 150 psi	NPS 1 1/4 – 2	
Détendeur alimentaire / Pressure reducing valve	2371-1	DIN	Acier / steel	$P_{max} T = 20^{\circ}C$ 10 bar	DN 32 – 50	Tous fluides / all fluids
		ANSI		$P_{max} T = 70^{\circ}F$ 150 psi	NPS 1 1/4 – 2	
Vanne de régulation passage droit / Globe valve	2423	à membrane with diaphragm	Fonte grise / cast iron	PN25	DN 65 – 125	G2 (L2 1)
		à soufflet with bellow	Fonte sphéroïdale / spheroidal graphite iron	PN25	DN 50 – 125	
Vanne de régulation passage droit / Globe valve	3241	DIN	Fonte grise / cast iron	PN16	DN 65 – 100	G2, L1, L2 1)
		DIN	Fonte grise & fonte sphéroïdale / cast iron & spheroidal graphite iron	PN25	DN 50 – 100	
		DIN	Fonte sphéroïdale / spheroidal graphite	PN40	DN 40 – 100	
		ANSI	Fonte grise / cast iron	PN10	DN 125 – 150	
		DIN	Fonte sphéroïdale / spheroidal graphite	PN16	DN 65 – 125	
		ANSI	Fonte grise / cast iron	PN 25	DN 50 – 80	
Vanne de régulation 3 voies / 3-way Valve	3244	DIN	Acier / steel	CI 125 CI 250	NPS 2 1/2 – 4 NPS 1 1/2 – 2	Tous fluides / all fluids
		DIN	Fonte grise / cast iron	PN10	DN 32 – 100	
		ANSI	Acier / steel	PN16 PN25	DN 32 – 50 DN 32 – 40	
		DIN	Fonte grise / cast iron	CI 150	NPS 1 1/4 – 2	
Vanne de régulation passage droit / Globe valve	3251	DIN	Acier / steel	PN10	DN 125 – 150	G2, L1, L2 1)
		ANSI	Fonte grise / cast iron	PN16	DN 65 – 125	
Vanne équerre / Angle valve	3256	DIN	Acier / steel	PN10	DN 32 – 100	Tous fluides / all fluids
		ANSI	Acier / steel	PN16 PN25	DN 32 – 50 DN 32 – 40	
Vanne à segment sphérique / Segment ball valve	3310	DIN	Acier / steel	PN16	DN 32 – 50	Tous fluides / all fluids
		ANSI	Acier / steel	PN25	DN 80 – 100	
Vanne de régulation passage droit / Globe valve	3321	DIN	Fonte grise / cast iron	CI 150	NPS 1 1/2 – 2	G2, L1, L2 1)
		ANSI	Fonte grise / cast iron	PN16	DN 65 – 100	
		DIN	Fonte sphéroïdale / spheroidal graphite iron	PN25	DN 50 – 80	
Vanne de régulation 3 voies / 3-way Valve	3323	DIN	Acier / steel	CI 150	NPS 1 1/2 – 2	Tous fluides / all fluids
		ANSI	Fonte grise / cast iron : GJL-250	PN16	DN 65 – 100	
Vanne papillon / Butterfly valve	3331	DIN	Fonte sphéroïdale / spheroidal graphite iron	PN25	DN 50 – 80	G2, L1, L2 1)
		DIN	Acier / steel	PN10	DN 100	
Vanne à membrane Diaphragm valve	3345	DIN	Acier / steel	$P_{max} T = 20^{\circ}C$ 10 bar $P_{max} T = 20^{\circ}C$ 16 bar	DN 32 – 100 DN 32 – 50	Tous fluides / all fluids
		ANSI	Acier / steel	$P_{max} T = 70^{\circ}F$ 150 psi or 230 psi	NPS 1 1/4 – 2	
		DIN	Fonte grise & fonte sphéroïdale / cast iron & spheroidal graphite iron	$P_{max} T = 20^{\circ}C$ 10 bar $P_{max} T = 20^{\circ}C$ 16 bar $P_{max} T = 20^{\circ}C$ 40 bar	DN 125 – 150 DN 65 – 125 DN 40 – 50	
		ANSI	Fonte grise & fonte sphéroïdale / cast iron & spheroidal graphite iron	$P_{max} T = 70^{\circ}F$ 150 psi $P_{max} T = 70^{\circ}F$ 230 psi $P_{max} T = 70^{\circ}F$ 580 psi	NPS 2 1/2 – 4 NPS 2 1/2 – 5 NPS 1 1/2 – 2	



DECLARATION UE DE CONFORMITE EU DECLARATION OF CONFORMITY

2/2

Module A / Modul A

DC014
2022-05

Appareils / Devices	Type	Exécution / Version	Matériau du corps / body Material	PN Class	DN NPS	Fluides / fluids
Vanne alimentaire / Sanitary valve	3347	DIN	Acier / steel	$P_{max} T = 20^{\circ}C$ 10 bar	DN 125 – 150	G2, L1, L2 ¹⁾
		ANSI		$P_{max} T = 70^{\circ}F$ 150 psi	NPS 5 – 6	
Vanne aseptique / Aseptic valve	3349	DIN	Acier / steel	$P_{max} T = 20^{\circ}C$ 10 bar	DN 32 – 100	Tous fluides / all fluids
		ANSI		$P_{max} T = 20^{\circ}C$ 16 bar	DN 32 – 50	
				$P_{max} T = 20^{\circ}C$ 25 bar	DN 32 – 40	
				$P_{max} T = 70^{\circ}F$ 150 psi	NPS 1 1/4 – 4	
Vanne Tout ou Rien / On-Off Valve	3351	DIN	Acier / steel	PN16	DN 32 – 50	Tous fluides / all fluids
		ANSI		PN25	DN 32 – 40	
		DIN	CI 150	NPS 1 1/4 – 2		
			Fonte grise & fonte sphéroïdale / cast iron & spheroidal graphite iron	PN16	DN 65 – 100	
			Fonte sphéroïdale / spheroidal graphite iron	PN25	DN 50 – 80	
			ANSI	CI 125	NPS 2 1/2 – 4	
Bride de mesure / Measure flange	5090	DIN	Acier / steel	PN6	DN 200 – 500	G2, L2 ¹⁾
				PN10	DN 125 – 350	
				PN16	DN 65 – 200	
				PN25	DN 50 – 125	
				PN40	DN 40 – 100	

¹⁾ Gas selon l'article 4 § 1.c) i) / Gases Acc. to article 4 paragraphs 1.c) i)
Liquide selon l'article 4 § 1.c) ii) / Liquids Acc. to article 4 paragraphs 1.c) ii)

la conformité avec le règlement suivant : / the conformity with the following requirement :

La Directive du Parlement Européen et du Conseil d'harmonisation des lois des Etats Membres concernant la mise à disposition sur le marché d'équipements sous pression / Directive of the European Parliament and of the Council on the Harmonization of the laws of the Member States relating of the making available on the market of pressure equipment	2014/68/UE 2014/68/EU	Du / of 15.05.2014
Procédure d'évaluation de la conformité appliquée pour les fluides selon l'Article 4 § 1 Applied conformity assessment procedure for fluids according to Article 4 § 1	Module A / Modul A	

Normes techniques appliquées / Technical standards applied :
DIN EN 12516-2, DIN EN 12516-3, ASME B16.34, DIN-EN 60534-4, DIN-EN 1092-1

Fabricant / manufacturer : Samson Régulation SAS, 1, rue Jean Corona, FR-69120 VAULX-EN-VELIN

Vaulx-en-Velin, le 23/05/22

Bruno Soulas
Directeur Stratégie et Développement / Head of Strategy and Development

Joséphine Signoles-Fontaine
Responsable du service QSE / Head of QSE Department



DECLARATION UE DE CONFORMITE EU DECLARATION OF CONFORMITY

1/2

Module H / Modul H, N°/ Nr CE-0062-PED-H-SAM 001-23-FRA

DC012
2023-06

Par la présente, SAMSON REGULATION SAS déclare sous sa seule responsabilité pour les produits suivants :
For the following products, SAMSON REGULATION SAS hereby declares under its sole responsibility:

Appareils / Devices	Type	Exécution / Version	Matériel du corps / body Material	PN Class	DN NPS	Fluides / fluids	
Vanne de régulation passage droit / globe valve	3241	DIN	Fonte grise & fonte sphéroïdale / cast iron & spheroidal graphite iron	PN 16	DN 150	G2, L1, L2 ¹⁾	
		ANSI		Cl 125	NPS 6		
		DIN	Fonte sphéroïdale / spheroidal graphite iron	PN 25	DN 100 – 150		
		DIN	Acier / steel	PN10	DN 125 – 150		Tous fluides / all fluids
				PN16	DN 65 – 150		
ANSI	Acier / steel	PN25	DN 50 – 150				
		PN40	DN 32 – 150				
		Cl 150	NPS 2 ½ – 6				
		Cl 300	NPS 1 ½ – 6				
Vanne de régulation 3 voies / 3-way Valve	3244	DIN	Fonte grise / cast iron	PN 16	DN 150	G2, L1, L2 ¹⁾	
		DIN	Acier / steel	PN10	DN 125 – 150	Tous fluides / all fluids	
				PN16	DN 65 – 150		
ANSI	Acier / steel	PN25	DN 50 – 150				
		PN40	DN 32 – 150				
		Cl 150	NPS 2 ½ – 6				
		Cl 300	NPS 1 ½ – 6				
Vanne de régulation passage droit / globe valve	3251	DIN	Acier / steel	PN16	DN 65 – 150	Tous fluides / all fluids	
		ANSI		PN25	DN 50 – 150		
Vanne haute pression / High pressure valve	3252	DIN	Acier / steel	PN40 – 400	DN 32 – 150		Tous fluides / all fluids
		ANSI		Cl 150	NPS 2 ½ – 6		
		Cl 300 - 2500	NPS 1 ½ – 6				
Vanne équerre / Angle valve	3256	DIN	Acier / steel	PN40 – 400	DN 32 – 80	Tous fluides / all fluids	
		ANSI		Cl 300 - 2500	NPS 1 ½ – 3		
Vanne à segment sphérique / Segment ball valve	3310	DIN	Acier / steel	PN16	DN 65 – 150		Tous fluides / all fluids
		ANSI		PN40 – 400	DN 32 – 150		
Vanne de régulation passage droit / globe valve	3321	DIN	Acier / steel	Cl 150	NPS 2 ½ – 6		
		ANSI		Cl 300	NPS 1 ½ – 6		
Vanne de régulation 3 voies / 3-way Valve	3323	DIN	Fonte sphéroïdale / spheroidal graphite iron	PN 25	DN 100	G2, L1, L2 ¹⁾	
		DIN	Acier / steel	PN16	DN 65 – 100	Tous fluides / all fluids	
				PN40	DN 32 – 100		
ANSI	Acier / steel	Cl 150	NPS 2 ½ – 4				
		Cl 300	NPS 1 ½ – 4				
Vanne papillon / Butterfly valve	3331	DIN	Acier / steel	PN10	DN 150 – 400		Tous fluides / all fluids
		ANSI		PN16 – 50	DN 100 – 400		
Vanne à membrane / Diaphragm valve	3345	ANSI	Fonte grise & fonte sphéroïdale / cast iron & spheroidal graphite iron	P _{max} T=70°F 150 psi	NPS 5 – 6	G2, L1, L2 ¹⁾	
			Acier / steel	P _{max} T=70°F 230 psi	NPS 6		
				P _{max} T=70°F 150 - 230 psi	NPS 2 ½ – 6		



DECLARATION UE DE CONFORMITE EU DECLARATION OF CONFORMITY

2/2

Module H / Modul H, N°/ Nr CE-0062-PED-H-SAM 001-23-FRA

DC012
2023-06

Appareils / Devices	Type	Exécution / Version	Matériel du corps / body Material	PN Class	DN NPS	Fluides / fluids
Vanne alimentaire / Sanitary valve	3347	DIN	Acier / steel	P _{max} T = 20°C 16 bar DN 65 – 150 DN 32 – 150	DN 150 DN 65 – 150 DN 32 – 150	G2, L1, L2 ¹⁾
		ANSI		P _{max} T = 20°C 230 psi P _{max} T = 70°F 580 psi P _{max} T = 70°F 910 psi	NPS 6 NPS 2 1/2 – 6 NPS 1 1/2 – 6	
Vanne Tout ou Rien / On-Off Valve	3351	DIN	Fonte sphéroïdale / spheroidal graphite iron	PN 25	DN 100	G2, L1, L2 ¹⁾
		DIN	Acier / steel	PN16 PN25 PN40	DN 65 – 100 DN 50 – 100 DN 32 – 100	Tous fluides / all fluids
		ANSI		Cl 150 Cl 300	NPS 2 1/2 – 4 NPS 1 1/2 – 4	
				PN10 PN16 PN25 PN40	DN 400 – 500 DN 250 – 500 DN 150 – 500 DN 125 – 500	G2, L2 ¹⁾

¹⁾ Gas selon l'article 4 § 1.c) i) / Gases Acc. to article 4 paragraphs 1.c) i)
Liquide selon l'article 4 § 1.c) ii) / Liquids Acc. to article 4 paragraphs 1.c) ii)

la conformité avec le règlement suivant : / the conformity with the following requirement:

La Directive du Parlement Européen et du Conseil d'harmonisation des lois des Etats Membres concernant la mise à disposition sur le marché d'équipements sous pression / Directive of the European Parliament and of the Council on the Harmonization of the laws of the Member States relating of the making available on the market of pressure equipment	2014/68/UE 2014/68/EU	Du / of 15.05.2014
Procédure d'évaluation de la conformité appliquée pour les fluides selon l'Article 4 § 1 Applied conformity assessment procedure for fluids according to Article 4 § 1	Module H / Modul H	Certificat n° CE- 0062-PED-H-SAM 001-23-FRA

Normes techniques appliquées / Technical standards applied :
DIN EN 12516-2, DIN EN 12516-3, ASME B16.34, DIN-EN 60534-4, DIN-EN 1092-1

Le système de contrôle Qualité du fabricant est effectué par l'organisme de certification suivant :
The manufacturer's quality management system is monitored by the following notified body:

Bureau Veritas Services SAS N°/Nr 0062, 8 Cours du Triangle, 92800 PUTEAUX - LA DEFENSE
Fabricant / manufacturer : Samson Régulation SAS, 1, rue Jean Corona, FR-69120 VAULX-EN-VELIN

Vaulx-en-Velin, le 19/06/23

Bruno Soulas
Directeur Général – Directeur Stratégie et Développement /
Director general - Head of Strategy and Development

Joséphine Signoles-Fontaine
Responsable du service QSE / Head of QSE department



EU DECLARATION OF CONFORMITY

DC028
2020-07

Declaration of Conformity of Final Machinery

in accordance with Annex II, section 1. A. of the Directive 2006/42/EC

For the following products:

Types 3310/AT and 3310/3278 consisting of the Type 3310 Segmented Ball Valve and Type AT / Type 3278 Pneumatic Actuator

We hereby declare that the machinery mentioned above complies with all applicable requirements stipulated in Machinery Directive 2006/42/EC.

For product descriptions of the valve and actuator, refer to:

- Types 3310/AT and 3310/3278 Valve: Mounting and Operating Instructions EB 8222
- Type 3278 Actuator: Mounting and Operating Instructions EB 8321

Valve accessories (e.g. positioners, limit switches, solenoid valves, lock-up valves, supply pressure regulators, volume boosters and quick exhaust valves) are classified as machinery components in this declaration of conformity and do not fall within the scope of the Machinery Directive as specified in § 35 and § 46 of the Guide to Application of the Machinery Directive 2006/42/EC issued by the European Commission. In the SAMSON Manual H 02 titled "Appropriate Machinery Components for SAMSON Pneumatic Control Valves with a Declaration of Conformity of Final Machinery", SAMSON defines the specifications and properties of appropriate machinery components that can be mounted onto the above specified final machinery.

Referenced technical standards and/or specifications:

- VCI, VDMA, VGB: "Leitfaden Maschinenrichtlinie (2006/42/EG) — Bedeutung für Armaturen, Mai 2018" [German only]
- VCI, VDMA, VGB: "Zusatzdokument zum „Leitfaden Maschinenrichtlinie (2006/42/EG) — Bedeutung für Armaturen vom Mai 2018" [German only], based on DIN EN ISO 12100:201 1-03

Comment:

Information on residual risks of the machinery can be found in the mounting and operating instructions of the valve and actuator as well as in the referenced documents listed in the mounting and operating instructions.

Persons authorized to compile the technical file:

SAMSON REGULATION SAS – 1 rue Jean Corona – FR-69120 VAULX-EN-VELIN
Vaulx-en-Velin, 30 July 2020

Michael Lachenal-Chevallet
R&D Manager

Joséphine Signoles-Fontaine
QSE Manager



DECLARATION OF INCORPORATION

DC040
2022-12

Declaration of Incorporation in compliance with Machinery Directive 2006/42/EC

For the following products:

Type 3310 Segmented Ball Valve

We certify that the Type 3310 Segmented Ball Valves are partly completed machinery as defined in the Machinery Directive 2006/42/EC and that the safety requirements stipulated in Annex I, 1.1.2, 1.1.3, 1.1.5, 1.3.2, 1.3.4 and 1.3.7 are observed. The relevant technical documentation described in Annex VII, part B has been compiled.

Products we supply must not be put into service until the final machinery into which it is to be incorporated has been declared in conformity with the provisions of the Machinery Directive 2006/42/EC.

Operators are obliged to install the products observing the accepted industry codes and practices (good engineering practice) as well as the mounting and operating instructions. Operators must take appropriate precautions to prevent hazards that could be caused by the process medium and operating pressure in the valve as well as by the signal pressure and moving parts.

The permissible limits of application and mounting instructions for the products are specified in the associated data sheets as well as the mounting and operating instructions; the documents are available in electronic form on the Internet at www.samsongroup.com.

For product descriptions of the valve, refer to Mounting and Operating Instructions EB 8222.

Referenced technical standards and/or specifications:

- VCI, VDMA, VGB: "Leitfaden Maschinenrichtlinie (2006/42/EG) — Bedeutung für Armaturen, Mai 2018" [German only]
- VCI, VDMA, VGB: "Zusatzdokument zum „Leitfaden Maschinenrichtlinie (2006/42/EG) — Bedeutung für Armaturen vom Mai 2018" [German only], based on DIN EN ISO 12100:201 1-03

Comments:

- See mounting and operating instructions for residual hazards.
- Also observe the referenced documents listed in the mounting and operation instructions.

Persons authorized to compile the technical file:

SAMSON REGULATION SAS – 1 rue Jean Corona – FR-69120 VAULX-EN-VELIN
Vaulx-en-Velin, 23rd December 2022

Bruno Soulas
General Director
Head of Strategy and Development

Joséphine Signoles-Fontaine
Head of QSE department

WIEBEN * FR025865

SAMSON REGULATION SAS • 1 rue Jean Corona • 69120 Vaulx-en-Velin
Tel.: +33 (0)4 72 04 75 00 • E-mail: france@samsongroup.com • Internet: www.samson.fr
Société par actions simplifiée au capital de 10 000 000 € • Siège social : Vaulx-en-Velin
N° SIRET: RCS Lyon B 788 165 603 00127 • N° de TVA: FR 86 788 165 603 • Code APE 2814Z

BNP Paribas N° compte 0002200215245 • Banque 3000401857
IBAN FR7630004018570002200215245 • BIC (code SWIFT) BNPAFRPPVBE
Crédit Lyonnais N° compte 0000060035841 • Banque 3000201936
IBAN FR9830002019360000060035841 • BIC (code SWIFT) CRLYFRPP



UK DECLARATION OF CONFORMITY

DC062
2022-12

The Pressure Equipment (Safety) Regulations 2016 Module A

For the following products, SAMSON REGULATION SAS hereby declares under its sole responsibility:

Devices	Type	Version	Body Material	PN Class	DN NPS	Fluids
Back pressure reducing valve	2371-0	DIN	Steel	$P_{max} T = 20^{\circ}C$ 10 bar	DN 32 – 50	All fluids
		ANSI		$P_{max} T = 70^{\circ}F$ 150 psi	NPS 1 ¼ – 2	
Pressure reducing valve	2371-1	DIN		$P_{max} T = 20^{\circ}C$ 10 bar	DN 32 – 50	
		ANSI		$P_{max} T = 70^{\circ}F$ 150 psi	NPS 1 ¼ – 2	
Globe valve	2423	à membrane with diaphragm	Cast iron	PN25	DN 65 - 125	G2 /L2 1)
		à soufflet with bellow	Spheroidal graphite iron	PN25	DN 50 - 125	
Globe valve	3241	DIN	Cast iron	PN16	DN 65 – 100	G2, L1, L2 1)
		DIN	Cast iron & spheroidal graphite iron	PN25	DN 50 - 100	
		DIN	Spheroidal graphite	PN40	DN 40 - 100	
		ANSI	Cast iron	PN10	DN 125 – 150	
		ANSI	Cast iron	PN16	DN 65 – 125	
		ANSI	Cast iron	PN 25	DN 50 - 80	
3-way Valve	3244	DIN	Cast iron	CI 125	NPS 2 ½ - 4	G2, L1, L2 1)
		DIN	Steel	CI 250	NPS 1 ½ - 2	
		ANSI	Steel	PN10	DN 32 – 100	
		ANSI	Steel	PN16	DN 32 – 50	
Globe valve	3251	DIN	Steel	PN25	DN 32 - 40	All fluids
		ANSI	Steel	CI 150	NPS 1 ¼ - 2	
Angle valve	3256	DIN	Steel	PN16	DN 32 – 50	All fluids
		ANSI	Steel	CI 150	NPS 1 ¼ - 2	
Segment ball valve	3310	DIN	Steel	PN10	DN 40 – 50	All fluids
		ANSI	Steel	PN16	DN 80 – 100	
Globe valve	3321	DIN	Cast iron	PN25	DN 40	G2, L1, L2 1)
		ANSI	Cast iron	CI 150	NPS 1 ½ – 2	
		DIN	Spheroidal graphite iron	PN16	DN 65 – 100	
		ANSI	Steel	PN25	DN 50 – 80	
3-way Valve	3323	DIN	Cast iron : GJL-250	CI 150	NPS 1 ½ - 2	All fluids
		DIN	Spheroidal graphite iron	PN16	DN 65 – 100	
Butterfly valve	3331	DIN	Steel	PN25	DN 50 – 80	G2, L1, L2 1)
Diaphragm valve	3345	DIN	Steel	$P_{max} T = 20^{\circ}C$ 10 bar	DN 32 – 100	All fluids
		ANSI		$P_{max} T = 20^{\circ}C$ 16 bar	DN 32 – 50	
		DIN	Cast iron & spheroidal graphite iron	$P_{max} T = 70^{\circ}F$ 150 psi or 230 psi	NPS 1 ¼ – 2	
		ANSI		$P_{max} T = 20^{\circ}C$ 10 bar	DN 125 – 150	
Globe valve	3345	DIN	Cast iron	$P_{max} T = 20^{\circ}C$ 16 bar	DN 65 – 125	G2, L1, L2 1)
		ANSI	Cast iron	$P_{max} T = 20^{\circ}C$ 40 bar	DN 40 – 50	
		DIN	Spheroidal graphite iron	$P_{max} T = 70^{\circ}F$ 150 psi	NPS 2 ½ – 4	
		ANSI	Steel	$P_{max} T = 70^{\circ}F$ 230 psi	NPS 2 ½ – 5	
Butterfly valve	3331	DIN	Steel	$P_{max} T = 20^{\circ}C$ 580 psi	NPS 1 ½ – 2	All fluids
		ANSI	Steel	$P_{max} T = 70^{\circ}F$ 830 psi	NPS 1 ½ – 2	

WEEEN FR02645

SAMSON REGULATION SAS • 1 rue Jean Corona • 69120 Vaulx-en-Velin
Tel. : +33 (0)4 72 04 75 00 • E-mail: france@samsongroup.com • Internet: www.samson.fr
N° SIRET: RCS Lyon B 788 165 603 00127 • N° de TVA: FR 86 788 165 603 • Code APE 2814Z

BNP Paribas N° compte 0002200215245 • Banque 3000401857
IBAN FR76300040185700020020215245 • BIC (code SWIFT) BNPFRPP33
Crédit Lyonnais N° compte 0000060035B41 • Banque 300021936
IBAN FR8930002019360000000035B41 • BIC (code SWIFT) CRLYFRPP



UK DECLARATION OF CONFORMITY

DC062
2022-12

Devices	Type	Version	Body Material	PN Class	DN NPS	Fluids
Sanitary valve	3347	DIN	Steel	P _{max} T = 20°C 10 bar	DN 125 – 150	G2, L1, L2 ¹⁾
		ANSI		P _{max} T = 70°F 150 psi	NPS 5 – 6	
Aseptic valve	3349	DIN	Steel	P _{max} T = 20°C 10 bar	DN 32 – 100	All fluids
				P _{max} T = 20°C 16 bar	DN 32 – 50	
		P _{max} T = 20°C 25 bar		DN 32 – 40		
		P _{max} T = 70°F 150 psi		NPS 1 ¼ – 4		
ANSI	P _{max} T = 70°F 230 psi	NPS 1 ¼ – 2				
	P _{max} T = 70°F 360 psi	NPS 1 ½ – 1 ½				
On-Off Valve	3351	DIN	Steel	PN16	DN 32 – 50	All fluids
		ANSI		CI 150	NPS 1 ¼ – 2	
		DIN	Cast iron & spheroidal graphite iron	PN16	DN 65 – 100	
		ANSI	Spheroidal graphite iron	PN25	DN 50 – 80	
			Cast iron	CI 125	NPS 2 ½ – 4	
Measure flange	5090	DIN	Steel	PN6	DN 200 – 500	G2, L2 ¹⁾
				PN10	DN 125 – 350	
				PN16	DN 65 – 200	
				PN25	DN 50 – 125	
				PN40	DN 40 – 100	

¹⁾ Gases Acc. to article 4 paragraphs 1. c) i)
Liquids Acc. to article 4 paragraphs 1. c) ii)

the conformity with the following Union harmonization legislation:

Legislation : STATUTORY INSTRUMENTS – 2016 No. 1105 – CONSUMER PROTECTION HEALTH AND SAFETY – The Pressure Equipment (Safety) Regulations 2016	PE(S)R 2016	2022
Applied conformity assessment procedure for fluids according to Article 4 § 1	2014/68/UE Modul A	

Applied designated standards and technical specifications: EN 12516-2, EN 12516-3, ASME B16.34, EN 60534-4, EN 1092-1

Manufacturer : Samson Régulation SAS, 1, rue Jean Corona, FR-69120 VAULX-EN-VELIN

Vaulx-en-Velin, 23rd December 2022

Bruno Soulas
General Director
Head of Strategy and Development

Joséphine Signoles-Fontaine
Head of QSE department

WEEE N° FR022685

SAMSON REGULATION SAS • 1 rue Jean Corona • 69120 Vaulx-en-Velin
Tel: +33 (0)4 72 04 75 00 • E-mail: france@samsongroup.com • Internet: www.samson.fr
Société par actions simplifiée au capital de 10 000 000 € • Siège social : Vaulx-en-Velin
N° SIRET: RCS Lyon B 788 165 603 00127 • N° de TVA: FR 86 788 165 603 • Code APE 2814Z

BNP Paribas N° compte 0002200215245 • Banque 3000401857
IBAN FR7630004018570002200215245 • BIC (code SWIFT) BNPFRPP33
Crédit Lyonnais N° compte 000060035841 • Banque 3000201936
IBAN FR983000201936000060035841 • BIC (code SWIFT) CRLYFRPP



UK DECLARATION OF CONFORMITY

DC064
2022-12

The Pressure Equipment (Safety) Regulations 2016 Module H / N° CE-0062-PED-H-SAM 001-20-FRA-rev-A

For the following products, SAMSON REGULATION SAS hereby declares under its sole responsibility:

Devices	Type	Version	Body Material	PN Class	DN NPS	Fluids
Globe valve	3241	DIN	Cast iron & spheroidal graphite iron	PN 16	DN 150	G2, L1, L2 ¹⁾
		ANSI		CI 125	NPS 6	
		DIN	Spheroidal graphite iron	PN 25	DN 100 – 150	All fluids
		ANSI	Steel	PN10 PN16 PN25 PN40	DN 125 – 150 DN 65 – 150 DN 50 – 150 DN 32 – 150	
		ANSI		CI 150 CI 300	NPS 2 ½ - 6 NPS 1 ½ - 6	
3-way Valve	3244	DIN	Cast iron	PN 16	DN 150	G2, L1, L2 ¹⁾
		DIN	Steel	PN10 PN16 PN25 PN40	DN 125 – 150 DN 65 – 150 DN 50 – 150 DN 32 – 150	All fluids
		ANSI		CI 150 CI 300	NPS 2 ½ - 6 NPS 1 ½ - 6	
				ANSI		CI 150 CI 300
Globe valve	3251	DIN	Steel	PN16 PN25 PN40 – 400	DN 65 – 150 DN 50 – 150 DN 32 – 150	All fluids
		ANSI		CI 150 CI 300 - 2500	NPS 2 ½ - 6 NPS 1 ½ - 6	
High pressure valve	3252	DIN	Steel	PN40 – 400	DN 32 – 80	All fluids
		ANSI		CI 300 - 2500	NPS 1 ½ - 3	
Angle valve	3256	DIN	Steel	PN16 PN40 – 400	DN 65 – 150 DN 32 – 150	All fluids
		ANSI		CI 150 CI 300 - 2500	NPS 2 ½ - 6 NPS 1 ½ - 6	
Segment ball valve	3310	DIN	Steel	PN10 PN16 PN25 PN40	DN 150 DN 80 – 150 DN 50 – 150 DN 40 – 150	All fluids
		ANSI		CI 150 CI 300	NPS 3 – 6 NPS 1 ½ - 6	
Globe valve	3321	DIN	Spheroidal graphite iron	PN 25	DN 100	G2, L1, L2 ¹⁾
		DIN	Steel	PN16 PN40	DN 65 – 100 DN 32 – 100	All fluids
		ANSI		CI 150 CI 300	NPS 2 ½ - 4 NPS 1 ½ - 4	
3-way Valve	3323	DIN	Spheroidal graphite iron	PN 25	DN 100	G2, L1, L2 ¹⁾
		DIN	Steel	PN16 PN40	DN 65 – 100 DN 32 – 100	All fluids
		ANSI		CI 150 CI 300	NPS 2 ½ - 4 NPS 1 ½ - 2	
Butterfly valve	3331	DIN	Steel	PN10 PN16 – 50	DN 150 – 400 DN 100 – 400	All fluids
		ANSI		CI 150 – 300	NPS 4 – 16	
Diaphragm valve	3345	ANSI	Cast iron & spheroidal graphite iron	P _{max} T _e 70°F 150 psi	NPS 5 – 6	G2, L1, L2 ¹⁾
			Steel	P _{max} T _e 70°F 230 psi	NPS 6	
				P _{max} T _e 70°F 150 - 230 psi	NPS 2 ½ - 6	All fluids

WEEEN° FR02645

SAMSON REGULATION SAS • 1 rue Jean Corona • 69120 Vaulx-en-Velin
Tel.: +33 (0)4 72 04 75 00 • E-mail: france@samsongroup.com • Internet: www.samson.fr

Société par actions simplifiée au capital de 10 000 000 € • Siège social : Vaulx-en-Velin
N° SIRET: RCS Lyon B 788 165 603 00127 • N° de TVA: FR 86 788 165 603 • Code APE 28142

BNP Paribas N° compte 00020020215245 • Banque 3000401857
IBAN FR763000401857000200215245 • BIC (code SWIFT) BNPAPRPP3VE

Crédit Lyonnais N° compte 0000060035B41 • Banque 3000201936
IBAN FR893000201936000000035B41 • BIC (code SWIFT) CRLYFRPP



UK DECLARATION OF CONFORMITY

**DC064
2022-12**

Devices	Type	Version	Body Material	PN Class	DN NPS	Fluids
Sanitary valve	3347	DIN	Steel	P _{max} T = 20°C 16 bar P _{max} T = 20°C 40 bar P _{max} T = 20°C 63 bar	DN 150 DN 65 – 150 DN 32 – 150	G2, L1, L2 ¹⁾
		ANSI		P _{max} T = 70°F 230 psi P _{max} T = 70°F 580 psi P _{max} T = 70°F 910 psi	NPS 6 NPS 2 ½ – 6 NPS 1 ½ – 6	
Aseptic valve	3349	DIN	Steel	P _{max} T = 20°C 16 bar P _{max} T = 20°C 25 bar P _{max} T = 70°F 230 psi P _{max} T = 70°F 360 psi	DN 65 – 100 DN 50 – 100 NPS 2 ½ – 4 NPS 2 – 4	All fluids
		ANSI				
On-Off Valve	3351	DIN	Spheroidal graphite iron	PN 25	DN 100	G2, L1, L2 ¹⁾
		DIN	Steel	PN16 PN25 PN40	DN 65 – 100 DN 50 – 100 DN 32 – 100	All fluids
		ANSI		CI 150 CI 300	NPS 2 ½ – 4 NPS 1 ½ – 4	
Measure flange	5090	DIN	Steel	PN10	DN 400 – 500	G2, L2 ¹⁾
				PN16	DN 250 – 500	
				PN25	DN 150 – 500	
				PN40	DN 125 – 500	

¹⁾ Gases Acc. to article 4 paragraphs 1.c) i)
Liquids Acc. to article 4 paragraphs 1.c) ii)

the conformity with the following Union harmonization legislation:

Legislation : STATUTORY INSTRUMENTS – 2016 No. 1105 – CONSUMER PROTECTION HEALTH AND SAFETY – The Pressure Equipment (Safety) Regulations 2016	PE(S)R 2016	2022
Applied conformity assessment procedure for fluids according to Article 4 § 1	2014/68/UE Modul H	Certificate n° CE-0062-PED- H-SAM 001-20- FRA-rev-A

Applied designated standards and technical specifications: EN 12516-2, EN 12516-3, ASME B16.34, EN 60534-4, EN 1092-1

The manufacturer's quality management system is monitored by the following notified body:
Bureau Veritas Services SAS N°/Nr 0062, 8 Cours du Triangle, 92800 PUTEAUX - LA DEFENSE

Manufacturer : Samson Régulation SAS, 1, rue Jean Corona, FR-69120 VAULX-EN-VELIN

Vaulx-en-Velin, 23rd December 2022

Bruno Soulas
General Director
Head of Strategy and Development

Joséphine Signoles-Fontaine
Head of QSE department

WEEE n° FR029845

SAMSON REGULATION SAS • 1 rue Jean Corona • 69120 Vaulx-en-Velin
Tel.: +33 (0)4 72 04 75 00 • E-mail: france@samsongroup.com • Internet: www.samson.fr
Société par actions simplifiée au capital de 10 000 000 € • Siège social : Vaulx-en-Velin
N° SIRET: RCS Lyon B 788 165 603 00127 • N° de TVA: FR 98 788 165 603 • Code APE: 2814Z

BNP Paribas N° compte 0002200215245 • Banque 3000401857
IBAN FR7630004018570002200215245 • BIC (code SWIFT) BNPFAFRPPVBE
Crédit Lyonnais N° compte 000060035841 • Banque 3000201936
IBAN FR983000201936000060035841 • BIC (code SWIFT) CRLYFRPP



Declaration of Conformity of Final Machinery

in accordance with Annex II, section 1. A. of the Machinery (Safety) Regulations 2008

For the following products:

Types 3310/AT and 3310/3278 consisting of the Type 3310 Segmented Ball Valve and Type AT / Type 3278 Pneumatic Actuator

We hereby declare that the machinery mentioned above complies with all applicable requirements stipulated in Machinery (Safety) Regulations 2008.

For product descriptions of the valve and actuator, refer to:

- Types 3310/AT and 3310/3278 Valve: Mounting and Operating Instructions EB 8222
- Type 3278 Actuator: Mounting and Operating Instructions EB 8321

Valve accessories (e.g. positioners, limit switches, solenoid valves, lock-up valves, supply pressure regulators, volume boosters and quick exhaust valves) are classified as machinery components in this declaration of conformity and do not fall within the scope of the Machinery Directive as specified in § 35 and § 46 of the Guide to Application of the Machinery (Safety) Regulations 2008. In the SAMSON Manual H 02 titled "Appropriate Machinery Components for SAMSON Pneumatic Control Valves with a Declaration of Conformity of Final Machinery", SAMSON defines the specifications and properties of appropriate machinery components that can be mounted onto the above specified final machinery.

Referenced technical standards and/or specifications:

- VCI, VDMA, VGB: "Leitfaden Maschinenrichtlinie (2006/42/EG) — Bedeutung für Armaturen, Mai 2018" [German only]
- VCI, VDMA, VGB: "Zusatzdokument zum „Leitfaden Maschinenrichtlinie (2006/42/EG) — Bedeutung für Armaturen vom Mai 2018" [German only], based on DIN EN ISO 12100:201 1-03

Comment:

Information on residual risks of the machinery can be found in the mounting and operating instructions of the valve and actuator as well as in the referenced documents listed in the mounting and operating instructions.

Persons authorized to compile the technical file:

SAMSON REGULATION SAS – 1 rue Jean Corona – FR-69120 VAULX-EN-VELLIN
Vaulx-en-Velin, 23rd December 2022

Bruno Soulas
General Director
Head of Strategy and Development

Joséphine Signoles-Fontaine
Head of QSE department



UK DECLARATION OF INCORPORATION

DC056
2022-12

Declaration of Incorporation of Partly Completed Machinery

In accordance with Schedule 2 Part 2 Annex II, section 1.B of the Directive 2008 No. 1597 Supply of Machinery (Safety) Regulations 2008

For the following products:

Type 3310 Segmented Ball Valve

We certify that the Type 3310 Segmented Ball Valves are partly completed machinery as defined in the Directive 2008 No. 1597 Supply of Machinery (Safety) Regulations 2008 and that the safety requirements stipulated in Annex I, 1.1.2, 1.1.3, 1.1.5, 1.3.2, 1.3.4 and 1.3.7 are observed. The relevant technical documentation described in Annex VII, (Part 7 of Schedule 2) part B has been compiled.

Products we supply must not be put into service until the final machinery into which it is to be incorporated has been declared in conformity with the provisions of the Directive 2008 No. 1597 Supply of Machinery (Safety) Regulations 2008.

Operators are obliged to install the products observing the accepted industry codes and practices (good engineering practice) as well as the mounting and operating instructions. Operators must take appropriate precautions to prevent hazards that could be caused by the process medium and operating pressure in the valve as well as by the signal pressure and moving parts.

The permissible limits of application and mounting instructions for the products are specified in the associated data sheets as well as the mounting and operating instructions; the documents are available in electronic form on the Internet at www.samsongroup.com.

For product descriptions of the valve, refer to Mounting and Operating Instructions EB 8222.

Referenced technical standards and/or specifications:

- VCI, VDMA, VGB: "Leitfaden Maschinenrichtlinie (2006/42/EG) — Bedeutung für Armaturen, Mai 2018" [German only]
- VCI, VDMA, VGB: "Zusatzdokument zum „Leitfaden Maschinenrichtlinie (2006/42/EG) — Bedeutung für Armaturen vom Mai 2018" [German only], based on DIN EN ISO 12100:201 1-03

Comments:

- See mounting and operating instructions for residual hazards.
- Also observe the referenced documents listed in the mounting and operation instructions.

Persons authorized to compile the technical file:

SAMSON REGULATION SAS – 1 rue Jean Corona – FR-69120 VAULX-EN-VELIN
Vaulx-en-Velin, 23rd December 2022

Bruno Soulas
General Director
Head of Strategy and Development

Joséphine Signoles-Fontaine
Head of QSE department

WEEE N° FR160268

SAMSON REGULATION SAS • 1 rue Jean Corona • 69120 Vaulx-en-Velin
Tel.: +33 (0)4 72 04 75 00 • E-mail: france@samsongroup.com • Internet: www.samson.fr
Société par actions simplifiée au capital de 10 000 000 € • Siège social : Vaulx-en-Velin
N° SIRET: RCS Lyon B 788 165 603 00127 • N° de TVA: FR 86 788 165 603 • Code APE 2814Z

BNP Paribas N° compte 0002200215245 • Banque 3000401857
IBAN FR7630004018570002200215245 • BIC (code SWIFT) BNPFRPP30
Crédit Lyonnais N° compte 000060035841 • Banque 3000201936
IBAN FR983000201936000060035841 • BIC (code SWIFT) CRLYFRPP



KONFORMITÄTSERKLÄRUNG

Für folgende Produkte

Drehstellventile Typ 3310, 3331

Zeugnis Nr.: TSX71002520191338

Bewertungsberichte N r°: 2019TSFM746-TYP3310 NPS2
und 2019TSFM747-TYP3310 NPS6

DC017

2019-08

Die Ventile 3310 haben die Bewertungstests gemäß den Anforderungen der chinesischen Druckgeräte TSG D7002-2006 bestanden.

Infolgedessen erfüllen alle oben genannten Drehstellventile die Anforderungen der TSG D7002-2006 für chinesische Druckgeräte gemäß den folgenden Merkmalen:

- DN 50 bis 300 PN ≤ 5 MPa (50 bar) oder NPS 2 bis NPS 12 Class ≤ 300,
- Betriebstemperatur: -29°C ≤ T ≤ 220°C.

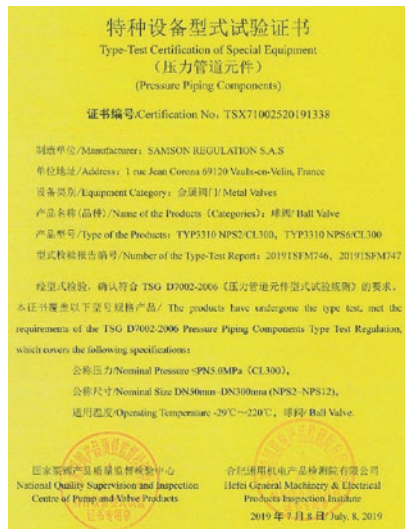

SAMSON REGULATION S.A.

Bruno Soulas
Leiter Verwaltung

SAMSON REGULATION S.A.

Joséphine Signoles-Fontaine
Qualitätsmanager

SAMSON REGULATION S.A.S.



1/1

DC027
2020-04

DECLARATION DE CONFORMITE DECLARATION OF CONFORMITY

符合性声明

La présente déclaration de conformité est établie sous la seule responsabilité du fabricant.
This declaration of conformity is issued under the sole responsibility of the manufacturer.
制造商对发布的符合性声明全权负责。

Nous certifions que les produits suivants en exécution standard :
For the following products in standard execution:
适用于下述型号的产品:

Type / type / 型号 : 2371, 3249, 3252, 3310, 3331, 3347, 3349, 3351, 3710, 3711, 5090, Samstation

sont conformes à la législation applicable :
the conformity with the relevant legislation is declared with:
声明符合相关法规:

China RoHS 2.0 GB/T26572-2011

Fabricant :
Manufacturier :
制造商

SAMSON REGULATION S.A.S.
1, rue Jean Corona
69120 Vaulx-en-Velin
France

Vaulx-en-Velin, le 20/04/2020

Au nom du fabricant,
On behalf of the Manufacturer,
制造商的代表人

SAMSON REGULATION S.A.S.

Joséphine SIGNOLES-FONTAINE
Responsable QSE
QSE Manager
QSE 负责人

SAMSON REGULATION - 1 rue Jean Corona - 69120 Vaulx-en-Velin
Tél. : +33 (0)4 72 04 75 00 - Fax : +33 (0)4 72 04 75 75 - E-mail: samson@samson.fr - Internet: www.samson.fr

Société par actions simplifiée au capital de 10 000 000 € - Siège social: Vaulx-en-Velin
N° SIRET: RCS Lyon B 788 165 603 00127 - N° de TVA: FR 86 788 165 603 - Code APE 2814Z

BNP Paribas

N° compte 0002200215245 - Banque 3000401857
IBAN FR7630004018570002200215245 - BIC (code SWIFT) BNPAPFRPP33

Crédit Lyonnais

N° compte 0000060035841 - Banque 3000201936
IBAN FR9830002019360000060035841 - BIC (code SWIFT) CRLYFRPP

SAMSON REGULATION S.A.S.



1/1

DECLARATION UE DE CONFORMITE
EU DECLARATION OF CONFORMITY
EU KONFORMITÄTSERKLÄRUNG

DC008
2021-12

La présente déclaration de conformité est établie sous la seule responsabilité du fabricant.
This declaration of conformity is issued under the sole responsibility of the manufacturer.
Die alleinige Verantwortung für die Ausstellung dieser Konformitätserklärung trägt der Hersteller.

Nous certifions pour les produits suivants en exécution standard :
For the following products in standard execution:
Für die folgenden Produkte in Standard-Ausführung:

Type / type / Typ : 2371, 3252, 3310, 3331, 3347, 3349, 3351, 3710, 3711, 3776, 3777, 3812, 3963,
3964, 3967, 4708, 4746, 5090, Samstation

sont conformes à la législation applicable harmonisée de l'Union :
the conformity with the relevant Union harmonization legislation is declared with:
wird die Konformität mit den einschlägigen Harmonisierungsrechtsvorschriften der Union bestätigt:

RoHS 2011/65/EU, 2015/863/EU

EN 50581:2012, IEC 63000:2016

Fabricant : SAMSON REGULATION S.A.S.
Manufacturer: 1, rue Jean Corona
Hersteller: 69520 Vaulx-en-Velin
France

Vaulx-en-Velin, le 14/12/21

Au nom du fabricant,
On behalf of the Manufacturer,
Im Namen des Herstellers,

SAMSON REGULATION S.A.S.

Joséphine SIGNOLES-FONTAINE
Responsable QSE



DECLARATION OF CONFORMITY**DC007****2021-12**

Regulation (EU) No. 1907/2006 (REACH, Registration, Evaluation, Authorisation and Restriction of Chemicals); United Nations Globally Harmonised System (UN GHS); and WFD, Waste Framework Directive (EU) 2008/98/EC, Article 9(1)(i) as amended by Directive (EU) 2018/851 of 30 May 2018, and their national implementations

We hereby certify that we are well informed about the REACH regulation, which entered into force on 1 June 2007 and have determined the applicable consequences and obligations, especially pre-registration and registration of substances, notifications to public bodies, authorization, and restriction. We manufacture "articles" as defined in the REACH Regulation Article 2. As a result, we are a "downstream user" in most cases. We do not produce any substances or mixtures that we sell.

Concerning the registration of the relevant substances we use to manufacture our products, we can inform you based on REACH Article 10 that, on the basis of the information presently available to us, we do not currently reach the threshold of one ton per year. It is possible for us to provide more precise data if required.

Concentration of SVHC (substances of very high concern) in SAMSON Products

We have a duty to communicate information to our customers on substances contained in our products according to Article 33 of the REACH Regulation: SAMSON calculate the contents of the substances in every individual article (e.g. nuts, bolts etc.) included in a bill of materials separately, following the judgment by the Court of Justice of the European Union concerning case C-106/14 of 16 October 2015, "Once an article, always an article" (O5A). SAMSON refer to a Candidate List of SVHC, that lists up the substances that we report:

These substances are often determined based on the classification of chemical substances and mixtures in the United Nations Global Harmonized System (UN GHS). We implement these systematics in Europe by following the Regulation (EC) No. 1272/2008 (CLP) on classification, labeling and packaging of substances and mixtures, forming a unified approach with the REACH Regulation. Both Safety Data Sheets (SDS, MSDS) for chemicals and chemical mixtures as well as SAMSON Material Data Sheets (MDS) for declaring a material and its substance content are prescribed by these regulations, based on an official list:

Compliance with the Candidate List of SVHC for Authorisation

Should you need to make reference to the most recent list, kindly see to the version published on the Internet, with the latest SAMSON references. Go to the following website to check whether the duty to communicate information according to REACH Article 33 applies to a SAMSON product:

<https://www.samsongroup.com/en/about-samson/material-compliance/reach-regulation/#c2723>

Also, we frequently cite further SVHC details on the delivery papers.

The Candidate List according to Article 59 (1, 10) of Regulation (EC) No. 1907/2006 (REACH) was first published on 1 September 2008. Since then, it is constantly expanded every six months by the European Chemicals Agency (ECHA). The Candidate List is regularly updated around the middle and end of every year. It now comprises of over 200 substances:

<https://www.echa.europa.eu/web/guest/candidate-list-table> (in English).

As a result, it is an on-going process to check whether our products contain SVHC in a concentration greater than 0.1% (w/w). We are in close contact with our suppliers as part of this process and we will inform you if we discover that any changes apply to us.



SCIP Database, “Substances of Concern In articles as such or in complex objects (Products)”

As legally requested by the Waste Framework Directive (WFD) since 5 January 2021 and the respective national implementation, SAMSON AG input the necessary data into the European Chemical Agency's (ECHA) SCIP Database.

The REACH Candidate List is updated every six months. SAMSON will not issue, every half a year, any more statements or fill in specific, non-standardized documents of proof in over 20 different formats that our articles are not affected.

It is legally only required to communicate the affected articles and (if the need be) their sub-articles to customers if SVHC surpass 0.1 % weight of weight in in articles or in separate articles as a part of more complex articles., as specified in REACH Article 33. Also, protective measures against SVHC have to be stated where applicable.

SAMSON REGULATION SAS
Vaulx-en-Velin, 14 December 2021

A handwritten signature in blue ink, appearing to read "Bruno Soulas", written over a horizontal line.

Bruno Soulas
Director of Strategy and Development

A handwritten signature in blue ink, appearing to read "Joséphine Signoles-Fontaine", written over a horizontal line.

Joséphine Signoles-Fontaine
Head of QSE Department



DECLARATION OF CONFORMITY

For the following product

DC021

2022-05

Industrial valves in special execution with seals and packings for food contact types 3241, 3321 CT, 3310, 3351 and 3252

Seals and packings comply with:

- European Regulation (EC) No. 1935/2004
- American rules FDA 21 CFR §177.1550 (PTFE) & §177.2415 (PEEK) & §177.2600 (Rubber).

Grease used for the assembly of parts in contact with the fluid is in conformity with the requirements of NSF-H1.

On 02/05/22

SAMSON REGULATION S.A.S.

A handwritten signature in blue ink, appearing to read "Soulas", written over a horizontal line.

Bruno Soulas
Director of Strategy and Innovation

A handwritten signature in blue ink, appearing to read "J. Signoles-Fontaine", written over a horizontal line.

Joséphine Signoles-Fontaine
QSE Manager



DECLARATION OF CONFORMITY

DC022

For the following product

2022-05

Industrial valves in special execution used in food or pharmaceutical environment types 3241, 3321 CT, 3310, 3351 and 3252.

For these valves, the materials (seals, glands and bodies), the preparation of the parts and the conditions of assembly are in accordance with:

- European Regulation (EC) No. 1935/2004
- American rules FDA 21 CFR §177.1550 (PTFE) & §177.2415 (PEEK) & §177.2600 (Rubber).

Grease used for the assembly of parts in contact with the fluid is in conformity with the requirements of NSF-H1.

Metals used for the metal components of the valve(s) listed above and in contact with the fluid belong to the list of AISI 300 series materials recognized by the FDA.

On 02/05/22

SAMSON REGULATION S.A.S.

A handwritten signature in blue ink, appearing to read "B. Soulas", written over a horizontal line.

Bruno Soulas
Director of Strategy and Innovation

A handwritten signature in blue ink, appearing to read "J. Signoles-Fontaine", written over a horizontal line.

Joséphine Signoles-Fontaine
QSE Manager

15 Annex

15.1 Tightening torques, lubricants and tools

► AB 0100 for tools, tightening torques and lubricants

15.2 Accessories

Table 15-3: *Wedge between valve shaft, shaft adapter and actuator*

NPS		1	1½	2	3	4	6	8	10	12
DN		25	40	50	80	100	150	200	250	300
Square drive connection		Width across flats SW for valve shaft square drive								
		12	12	12	12	19	19	27	27	27
		Item numbers of wedges (accessories)								
F05	VK14	7316	7348	–	–	–	–	–	–	–
F07	VK17	7317	7239	–	–	–	–	–	–	–
F10	VK22	–	–	7732	7240	–	–	–	–	–
F12	VK27	–	–	–	–	7241	7755	–	–	–
F14	VK36	–	–	–	–	7770	7243	–	–	–
F16	VK46	–	–	–	–	–	–	–	–	9613

15.3 Spare parts

01	Support shaft	21	Seat ring	65	Stud
02	Yoke	23	Washer	70	Retaining screw
03	Bottom flange	24	Sliding washer	75	Nut
05	Body	25	Support ring	80	Washer
07	Segmented ball	26	Metal O-ring	85	Screw
08	Arrow plate	27	Spring-loaded gasket	88	O-ring seal (optional)
09	Nameplate	30	Retainer	90	Seal
10	Spring	35	Bushing		
11	Key drive	40	Packing		
12	Valve shaft	46	Retainer seal		
15	Packing gland	49	Spacer		
17	Bearing bushing	55	Round-head grooved pin		
18	Bearing bushing				
20	Washer	60	Screw		

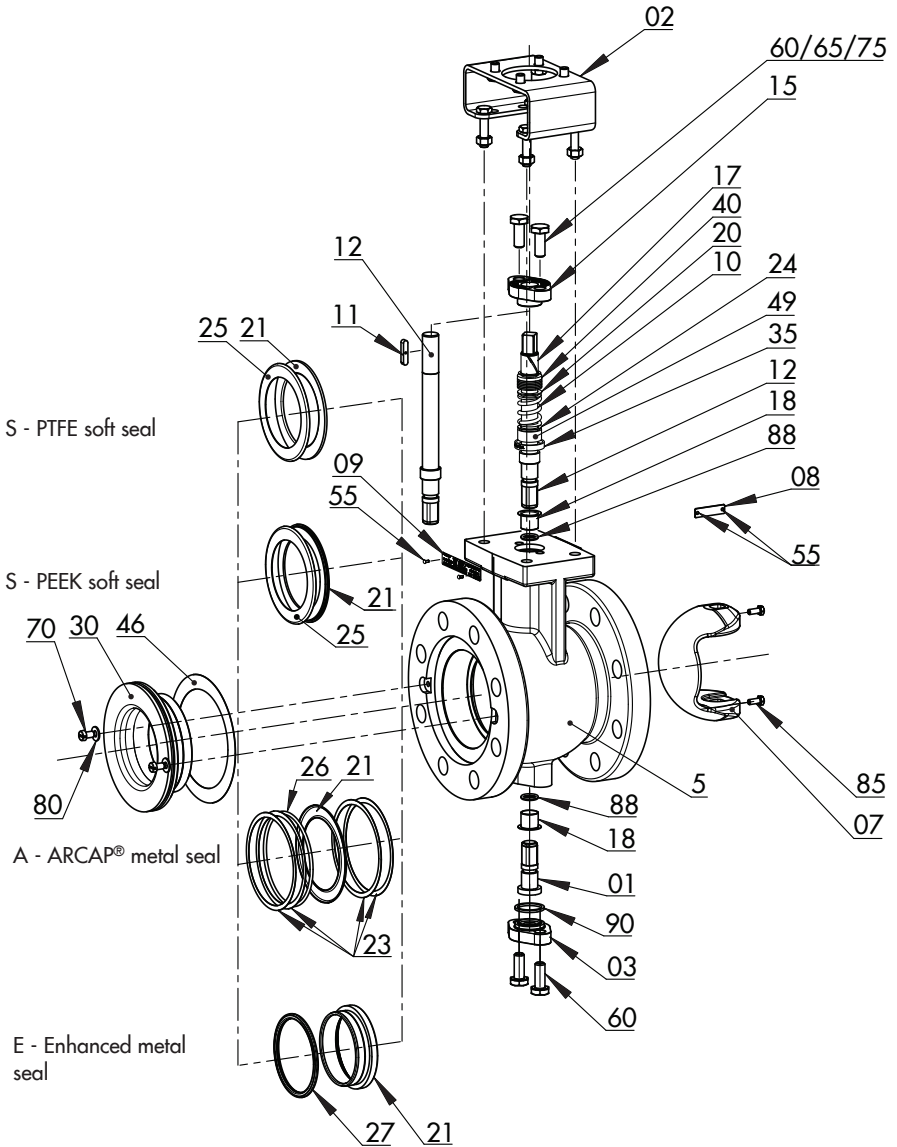

15.4 After-sales service

Contact our after-sales service for support concerning service or repair work or when malfunctions or defects arise.

E-mail address

You can reach our after-sales service at aftersalesservice@samsongroup.com.

Addresses of SAMSON AG and its subsidiaries

The addresses of SAMSON AG, its subsidiaries, representatives and service facilities worldwide can be found on our website (www.samsongroup.com) or in all SAMSON product catalogs.

Required specifications

Please submit the following details:

- Order number and position number in the order
- Type, model number, valve size and valve version
- Pressure and temperature of the process medium
- Flow rate in m³/h
- Direction of flow
- Bench range of the actuator (e.g. 0.2 to 1 bar)
- Is a strainer installed?
- Installation drawing

15.5 Information on the UK sales region

The following information corresponds to the 2016 Regulations No. 1105 Pressure Equipment (Safety) Regulations 2016, STATUTORY INSTRUMENTS, 2016 No. 1105 (UKCA marking). It does not apply to Northern Ireland.

Importer

SAMSON Controls Ltd
 Perrywood Business Park
 Honeycrock Lane
 Redhill, Surrey RH1 5JQ
 Phone: +44 1737 766391
 E-mail: sales-uk@samsongroup.com
 Website: uk.samsongroup.com

EB 8222-1 EN



SAMSON AKTIENGESELLSCHAFT
Weismüllerstraße 3 · 60314 Frankfurt am Main, Germany
Phone: +49 69 4009-0 · Fax: +49 69 4009-1507
samson@samsongroup.com · www.samsongroup.com