

Type 4708-45 Supply Pressure Regulator

with increased air capacity

SAMSON



Translation of original instructions

Mounting and Operating Instructions

EB 8546-1 EN

Edition March 2016

Note on these mounting and operating instructions

These mounting and operating instructions assist you in mounting and operating the device safely. The instructions are binding for handling SAMSON devices.

- For the safe and proper use of these instructions, read them carefully and keep them for later reference.
- If you have any questions about these instructions, contact SAMSON's After-sales Service Department (aftersaleservice@samson.de).



The mounting and operating instructions for the devices are included in the scope of delivery. The latest documentation is available on our website (www.samson.de) > Product documentation. You can enter the document number or type number in the [Find:] field to look for a document.

Definition of signal words

DANGER

Hazardous situations which, if not avoided, will result in death or serious injury

WARNING

Hazardous situations which, if not avoided, could result in death or serious injury

NOTICE

Property damage message or malfunction

Note

Additional information

Tip

Recommended action

1	General safety instructions	5
2	Design and principle of operation	6
2.1	Article code and versions	7
2.2	Technical data	8
2.3	Materials.....	9
3	Mounting the supply pressure regulator	10
4	Pneumatic connections	10
4.1	Pressure gauge	10
5	Adjusting the set point	11
6	Maintenance	11
7	Troubleshooting	12
8	Accessories/spare parts	12
9	Dimensions in mm	13

i Note

*These mounting and operating instructions apply exclusively to Type 4708-45 Supply Pressure Regulator. For details on other Type 4708-xx Supply Pressure Regulators ► **EB 8546**.*

1 General safety instructions

For your own safety, follow these instructions concerning the mounting, start-up, and operation of the device:

- The device is to be mounted, started up or operated only by trained and experienced personnel familiar with the product. According to these mounting and operating instructions, trained personnel refers to individuals who are able to judge the work they are assigned to and recognize possible dangers due to their specialized training, their knowledge and experience as well as their knowledge of the applicable standards.

To avoid damage to any equipment, the following also applies:

- Proper shipping and storage are assumed.

2 Design and principle of operation

The supply pressure regulator is used to supply pneumatic measuring and control equipment with a constant air supply. The maximum 12 bar pressure of the compressed air network in a plant is reduced to an adjustable minimum pressure of 0.5 to 6 bar.

The compressed air at the inlet (supply) flows across the filter and leaves the output with a reduced pressure depending on the set point

adjusted. The plug is balanced to eliminate the forces created by the upstream pressure acting on the plug.

Any water contained in the compressed air is separated and collected as condensate in the filter receptacle, which must be mounted suspended downwards. The collected condensate in the filter receptacle can be drained off by briefly pushing the drain plug

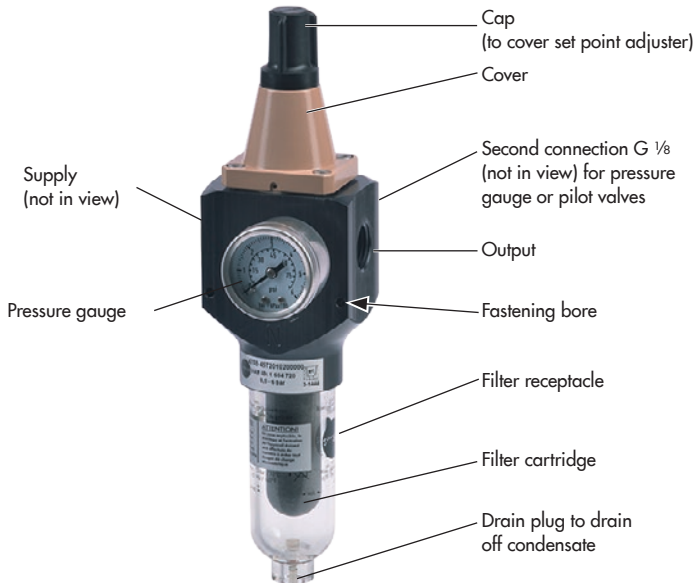

Fig. 1: Components of Type 4708-45 Supply Pressure Regulator (aluminum version)

2.1 Article code and versions

The supply pressure regulator is available with an aluminum or stainless steel body and a transparent plastic or metal filter receptacle.

The filter cartridge installed has a mesh size of 15 µm.

Supply pressure regulator	Type 4708-45	x	x	0	x	x	x	x	x	0	0	x
Connecting thread												
ISO-228/1 - G ½	6											
½-14 NPT	7											
Set point range												
0.5 to 6 bar, without pressure gauge	0											
0.5 to 6 bar, with pressure gauge, CrNiMo steel (device free of copper)	1											
0.5 to 6 bar, with pressure gauge (nickel-plated brass connection)	2											
No. of pressure gauges												
One pressure gauge				2								
Body material												
Aluminum (3.2315)					0							
Stainless steel (1.4409)					1							
Filter												
in transparent plastic receptacle						2						
in aluminum receptacle						3						
in stainless steel receptacle						4						
Temperature range												
-25 to +70 °C (standard)							0					
-50 to +70 °C, version for low temperatures							2					
Application												
Standard								0				
Device compatible with paint							0	1				
Special version												
Without										0	0	0

2.2 Technical data

Supply pressure regulator	Type 4708-45
Values measured with ½" connection	
Supply pressure	1 to 12 bar ¹⁾ (15 to 180 psi)
Set point range	0.2 to 1.6 bar (3 to 24 psi) or 0.5 to 6 bar (8 to 90 psi)
Air consumption at 7 bar supply pressure	≤0.1 m _n ³ /h
Dependency on inlet pressure	Negligible (< 10 mbar/4 bar)
Reversing error	50 mbar with set point range 0.5 to 6 bar (8 to 90 psi)
Hysteresis	50 mbar with set point range 0.5 to 6 bar (8 to 90 psi)
Filter cartridge mesh size	15 µm · Optionally 5 µm
Permissible ambient temperature	-25 to +70 °C ²⁾
Low-temperature version	-50 to +70 °C ²⁾
Weight	Approx. 0.74 kg ³⁾
Compliance	ERC
Pressure gauge	
Indicating range	0 to 1.6 bar (0 to 24 psi) or 0 to 6 bar (0 to 90 psi)
Connection	G ⅛

1) Recommendation: min. 1.0 bar (15 psi) above the adjusted set point

2) Applies also to rotating supplementary filter

3) With aluminum body and polyamide filter receptacle

2.3 Materials

Supply pressure regulator		Type 4708-45
Body	Metal parts	Aluminum ¹⁾ (3.3547) or stainless steel (1.4409)
	Plastic parts	Polyamide, glass fiber reinforced
Cover		Polyamide, glass fiber reinforced
Cap		Polyamide, glass fiber reinforced
Plug		1.4305 and polyoxymethylene
Diaphragm		NBR · FVMQ for low-temperature version
Diaphragm plate		Polyamide, glass fiber reinforced, or aluminum
Set point spring		1.4310
Filter receptacle		UV-resistant polyamide (Grilamid TR90UV)
Filter cartridge		15 µm: polypropylene and polyethylene
Pressure gauge		
Body		Stainless steel
Connection and measuring element		Nickel-plated brass or stainless steel for copper-free version

3 Mounting the supply pressure regulator

- To prevent excessive amounts of condensed water from collecting, keep the distance between the compressor and supply pressure regulator as short as possible.

The supply pressure regulator can either be mounted directly in the pipeline of the air supply or on rails or brackets using the corresponding mounting parts (see accessories in section 8).

- Observe the flow direction of the supply air. An arrow on the nameplate indicates the direction.

Depending on how the regulator is installed in the pipe, it may be necessary to mount the pressure gauge at the back of the supply pressure regulator (see section 4.1).

4 Pneumatic connections

The air connections (supply and output, see Fig. 1 on page 6) are designed either with ISO-228/1 - G ½ or ½-14 NPT threads.

The second pressure gauge on the back of the regulator can be used to additionally supply pilot valves with a constant supply pressure. This connection at the back has a G ⅛ thread.

4.1 Pressure gauge

- When attaching the pressure gauge, make sure that the gap between the lock nut and pressure gauge's square end is not smaller than 2 to 3 mm.

Mounting the pressure gauge on the back:

- Remove the stopper (hexagon socket head screw G ⅛) and screw it into the unoccupied pressure gauge connection at the front to seal it.

5 Adjusting the set point

- See Fig. 1 on page 6.
- Unscrew the cap on the set point screw and adjust the set point of the supply pressure regulator.
- Turning the knob or screw clockwise increases the output pressure and turning it counterclockwise reduces the output pressure.
- Lock the setting with the lock nut.

NOTICE

Risk of damage to the supply pressure regulator due to excessively high tightening torque.

Do not exceed the maximum permissible torque of 7 Nm.

6 Maintenance

WARNING

Risk of injury due to high pressure.

Shut off the air line before performing work on the supply pressure regulator.

Drain condensed water that has collected:

- Activate the manual drainage.
- Replace the gasket (order no. 0439-0061), if necessary.

Tip

We recommend to check the filter as often as possible.

7 Troubleshooting

⚠ WARNING

*Risk of injury due to high pressure.
Shut off the air line before performing work
on the supply pressure regulator.*

Leakage between supply pressure regulator and pneumatic connections:

→ Check the pipe fittings are fitted properly.

Leakage between supply pressure regulator and filter receptacle:

→ Make sure that the filter receptacle is attached properly.

Leakage at the drain plug:

→ Check the drain plug for dirt and clean or replace the filter receptacle, if necessary.

Air capacity drops and the output pressure drops:

→ Check the filter cartridge for dirt and make sure the set point is correctly adjusted.

Pressure drop

→ Unscrew the filter receptacle and renew the filter cartridge.

8 Accessories/spare parts

Article	Order no.
Filter cartridge 15 µm	8504-0068
Filter cartridge 5 µm	8504-9040
Filter receptacle, plastic	1199-0423
Filter receptacle, aluminum	1199-0424
Filter receptacle, stainless steel	1199-0425
Filter receptacle compatible with paint on request	
Seal for filter receptacle	
PVMQ	8421-0101
NBR (free of silicone)	8421-0102
Stopper (hex socket G 1/8)	0079-0100
Pressure gauge ¹⁾	
Stainless steel	0089-0025
Brass/stainless steel	0089-0026
Pressure gauge seal	1099-4305
Lock nut	0250-1949
Mounting bracket for Type 3271/3277 Actuator	1400-7343

¹⁾ With pressure compensation element

9 Dimensions in mm

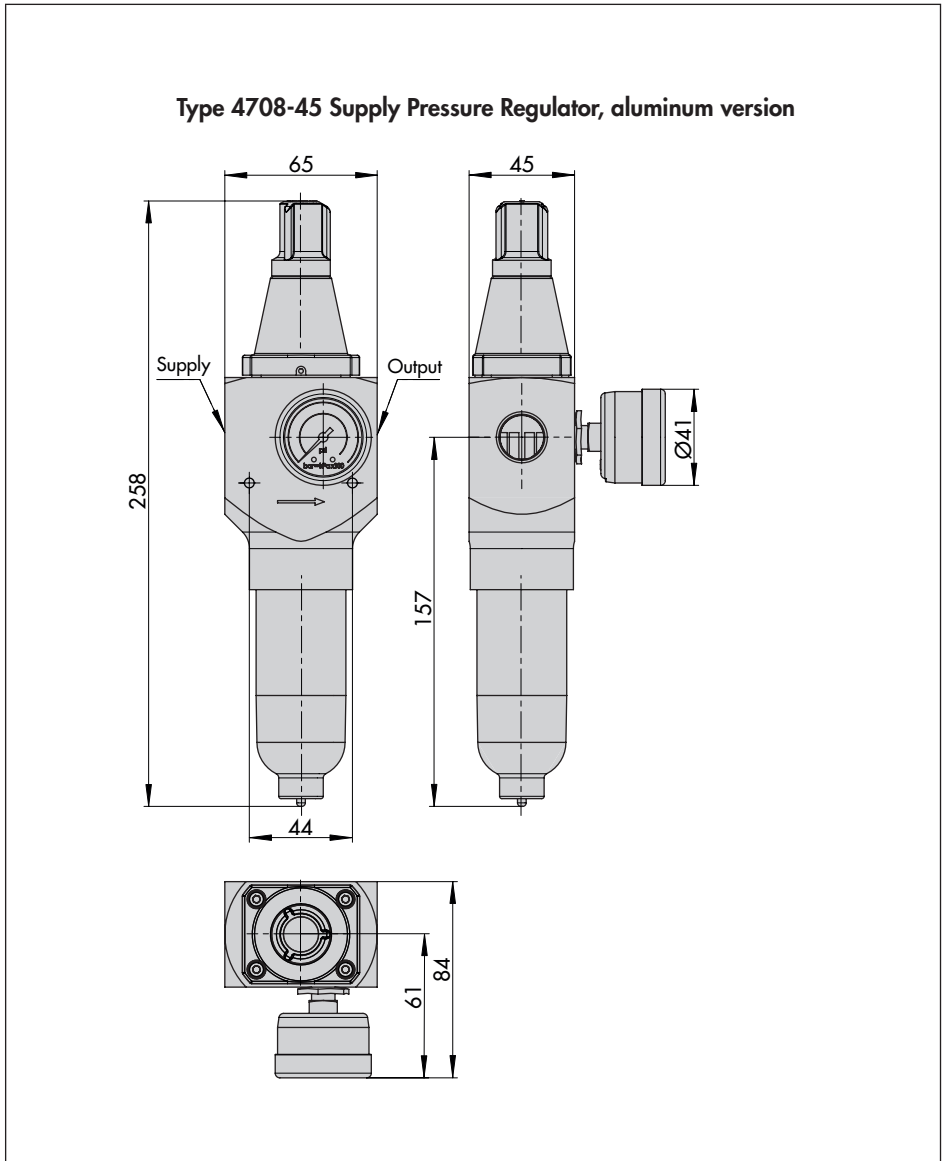

Type 4708-45 Supply Pressure Regulator, stainless steel version

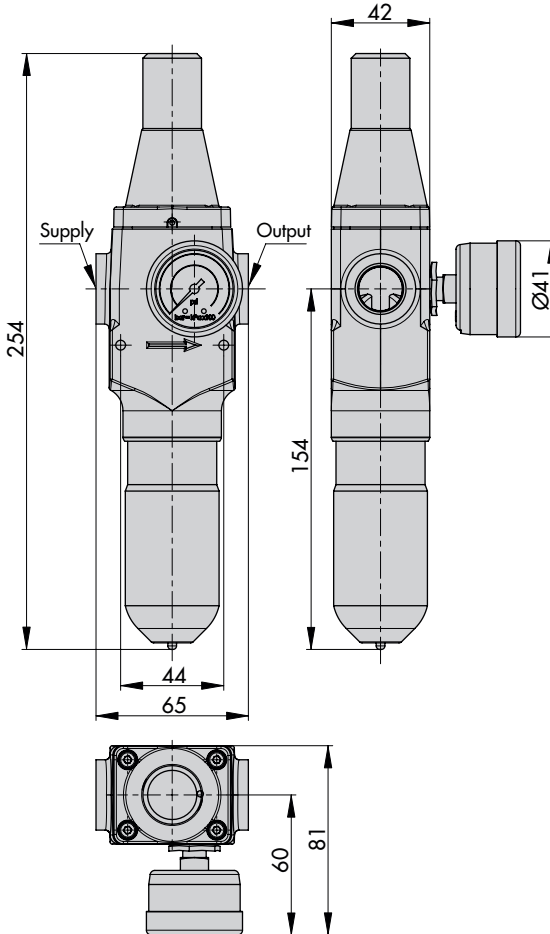



SAMSON AG · MESS- UND REGELTECHNIK
Weismüllerstraße 3 · 60314 Frankfurt am Main, Germany
Phone: +49 69 4009-0 · Fax: +49 69 4009-1507
samson@samson.de · www.samson.de

EB 8546-1 EN

2017-11-15 · English