

## T 2518 EN

### Type 41-73 Universal Excess Pressure Valve Self-operated Pressure Regulators · ANSI version



#### Application

Pressure regulators for set points from **0.75 to 400 psi/0.05 to 28 bar** · Valves in **NPS ½ to 4/DN 15 to 100** · Pressure rating **Class 125 to 300/PN 16 to 40** · Suitable for water, gases and vapors up to **660 °F/350 °C**

The valve **opens** when the **upstream** pressure rises.

#### Special features

- Low-maintenance proportional regulators requiring no auxiliary energy
- Frictionless plug stem seal with stainless steel bellows
- Control line kit available for tapping the pressure directly at the valve body
- Wide set point range and convenient set point adjustment using a nut
- Exchangeable set point springs and actuator
- Spring-loaded, single-seated valve with upstream and downstream pressure balancing <sup>1)</sup> by a stainless steel bellows
- Soft-seated plug for high shut-off requirements
- Low-noise plug (standard)
- All wetted parts free of non-ferrous metal

#### Versions

Excess pressure valve for controlling the upstream pressure  $p_1$  to the adjusted set point. The valve opens when the upstream pressure rises.

- **Type 41-73 · Standard version**  
Type 2417 Valve · Valve in NPS ½ to 4/DN 15 to 100  
Plug with metal seal · Body made of either cast iron A126B, cast steel A216 WCC or cast stainless steel A351 CF8M · Type 2413 Actuator with EPDM rolling diaphragm

#### Version with additional features

- **Excess pressure valve with increased safety**  
Actuator with leakage line connection and seal or two diaphragms and diaphragm rupture indicator

#### Special versions

- Control line kit for tapping the pressure directly at the valve body (accessories)

<sup>1)</sup> With  $C_v \leq 5/K_{vs} \leq 4$ : without balancing bellows

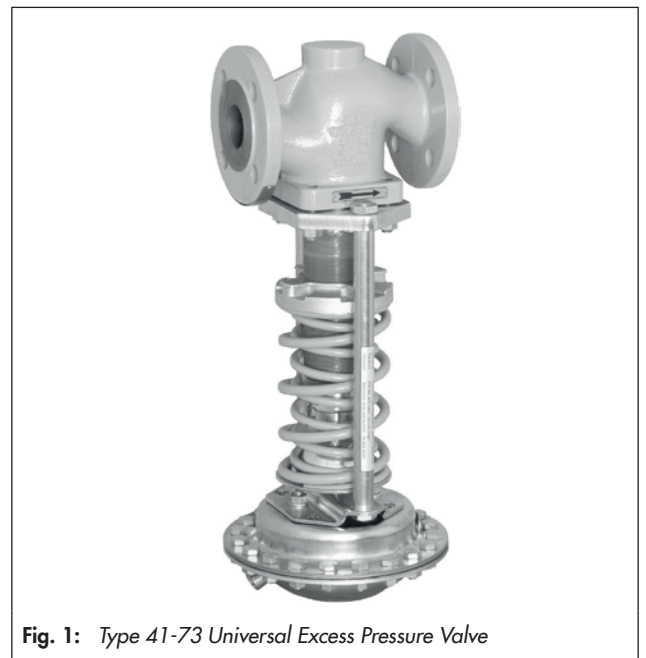

Fig. 1: Type 41-73 Universal Excess Pressure Valve

- With internal parts made of FKM, e.g. for use with mineral oils
- EPDM diaphragm with PTFE protective facing
- Actuator for remote set point adjustment (autoclave control)
- Bellows actuator for valves NPS ½ to 4/DN 15 to 100  
Set point ranges 30 to 85 psi, 75 to 145 psi, 145 to 320 psi, 300 to 400 psi/2 to 6 bar, 5 to 10 bar, 10 to 22 bar, 20 to 28 bar
- Valve with flow divider ST 1 for particularly low-noise operation with gases and vapors (▶ T 8081)
- Version entirely of stainless steel
- Stainless Cr steel seat and plug with PTFE soft seal (max. 440 °F/220 °C) or with EPDM soft seal (max. 300 °F/150 °C)

- Version for industrial gases
- Free of oil and grease for high-purity applications
- Stellite®-faced seat and plug for low-wear operation
- Wetted plastic parts conforming to FDA regulations (max. 140 °F/60 °C)

**Principle of operation (Fig. 2)**

The medium flows through the valve (1) as indicated by the arrow. The position of the plug (3) determines the flow rate across the area released between plug and valve seat (2). The plug stem (5) with the plug (3) is connected to the actuator stem (11) of the actuator (10).

To control the pressure, the operating diaphragm (12) is tensioned by the set point springs (7) and the set point adjuster (6) so that the valve is opened by the force of the set point springs when it is relieved of pressure ( $p_1 = p_2$ ).

The upstream pressure  $p_1$  to be controlled is tapped upstream of the valve and transmitted over the control line (14) to the operating diaphragm (12) where it is converted into a positioning force. This force is used to move the valve plug (3) according to the force of the set point spring (7).

The spring force is adjustable at the set point adjuster (6).

When the force resulting from the upstream pressure  $p_1$  rises above the adjusted set point, the valve opens proportionally to the change in pressure.

The fully balanced valve has a balancing bellows (4). The downstream pressure  $p_2$  acts on the inside of the bellows, whereas the upstream pressure  $p_1$  acts on the outside of the bellows. As a result, the forces produced by the upstream and downstream pressures acting on the plug are balanced out.

The valves can be supplied with flow divider ST 1. The valve seat must be replaced on retrofitting the flow divider.

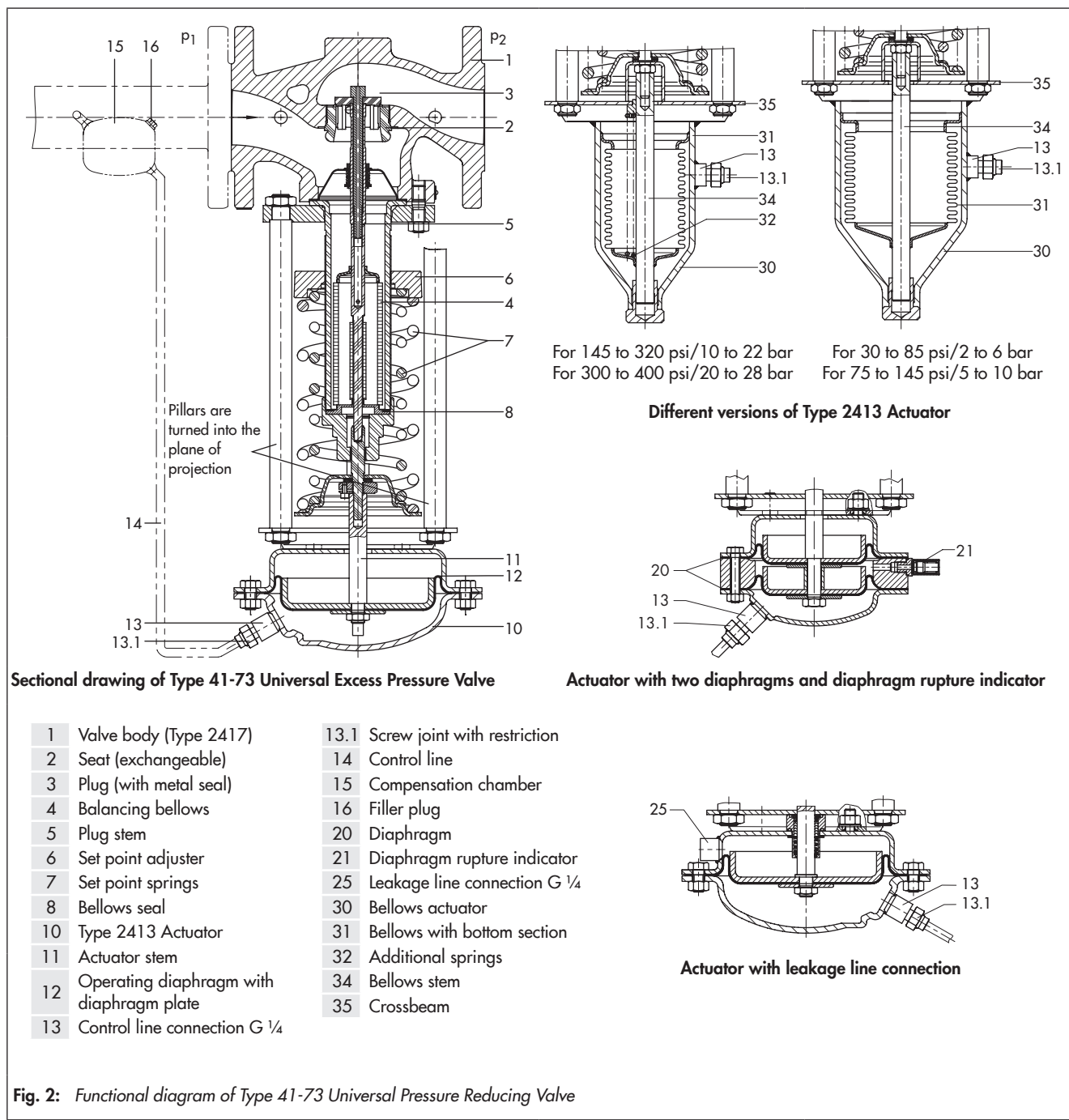

**Fig. 2:** Functional diagram of Type 41-73 Universal Pressure Reducing Valve

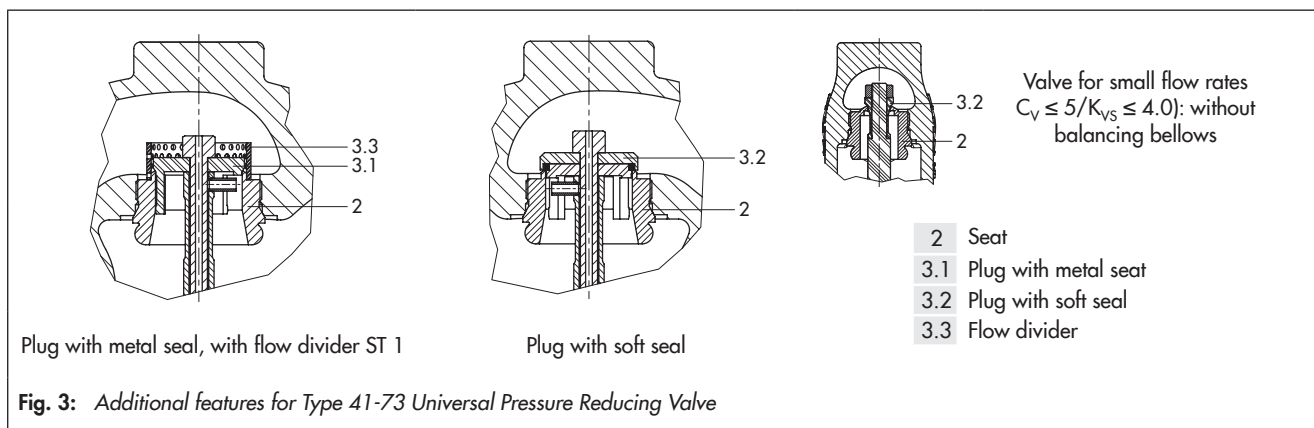

**Table 1:** Technical data · All pressures in psi and bar (gauge)

Valve		Type 2417		
Pressure rating	Class	125, 150 or 300		
	PN	16, 25 or 40		
Valve size	NPS	½ to 2	2½ and 3	4
	DN	15 to 50	65 to 80	100
Max. perm. differential pressure $\Delta p$	psi	360	290	230
	bar	25	20	16
Max. permissible temperature		See pressure-temperature diagram in ► T 2500		
	Valve plug	Metal seal: max. 660 °F/350 °C · PTFE soft seal: max. 430 °F/220 °C · EPDM, FPM soft seal: max. 300 °F/150 °C · NBR soft seal: max. 175 °F/80 °C		
Leakage class according to ANSI/FCI 70-2		Metal seal: leakage rate I ( $\leq 0.05$ % of $C_v/K_{vS}$ ) Soft seal: leakage rate IV ( $\leq 0.01$ % of $C_v/K_{vS}$ )		
Compliance		<b>CE · ENEC</b>		
<b>Diaphragm actuator</b>		<b>Type 2413</b>		
Set point ranges		0.75 to 3.5 psi · 1.5 to 8.5 psi · 3 to 17 psi · 10 to 35 psi <sup>1)</sup> 30 to 75 psi · 65 to 145 psi · 115 to 230 psi		
		0.05 to 0.25 bar · 0.1 to 0.6 bar · 0.2 to 1.2 bar · 0.8 to 2.5 bar <sup>1)</sup> 2 to 5 bar · 4.5 to 10 bar · 8 to 16 bar		
Max. permissible temperature		Gases 660 °F/350 °C, however, max. 175 °F/80 °C at the actuator · Liquids 300 °F/150 °C, with compensation chamber max. 660 °F/350 °C · Steam with compensation chamber max. 660 °F/350 °C		
<b>Bellows actuator</b>		<b>Type 2413</b>		
Actuator area		5.1 sq. in/33 cm <sup>2</sup>	9.6 sq. in/62 cm <sup>2</sup>	
Set point ranges		145 to 320 psi/10 to 22 bar 300 to 400 psi/20 to 28 bar	30 to 85 psi/2 to 6 bar 75 to 145 psi/5 to 10 bar	

<sup>1)</sup> Actuator with two diaphragms: 14.5 to 35 psi/1 to 2.5 bar

**Table 2:** Max. permissible pressure at actuator

Set point ranges · Actuator with rolling diaphragm						
0.75 to 3.5 psi/ 0.05 to 0.25 bar	1.5 to 8.5 psi/ 0.1 to 0.6 bar	3 to 17 psi/ 0.2 to 1.2 bar	10 to 35 psi/ 0.8 to 2.5 bar	30 to 75 psi/ 2 to 5 bar	65 to 145 psi/ 4.5 to 10 bar	115 to 230 psi/ 8 to 16 bar
Max. perm. pressure above the set point adjusted at the actuator						
9 psi/0.6 bar	9 psi/0.6 bar	19 psi/1.3 bar	36 psi/2.5 bar	73 psi/5 bar	145 psi/10 bar	145 psi/10 bar
Set point ranges · Bellows actuator						
30 to 85 psi/2 to 6 bar	75 to 145 psi/5 to 10 bar	145 to 320 psi/10 to 22 bar	300 to 400 psi/20 to 28 bar			
Max. perm. pressure above the set point adjusted at the actuator						
94 psi/6.5 bar	94 psi/6.5 bar	116 psi/8 bar	29 psi/2 bar			

**Table 3: Materials**

Valve	Type 2417		
Pressure rating	Class 125/PN 16	Class 150/PN 25 Class 300/PN 40	Class 150/PN 25 Class 300/PN 40
Max. permissible temperature	570 °F/300 °C	660 °F/350 °C	660 °F/350 °C
Body	Cast iron A126B	Cast steel A216 WCC	Cast stainless steel A351 CF8M
Seat	CrNi steel		CrNiMo steel
Plug	CrNi steel		CrNiMo steel
Seal for soft-seated plug	PTFE with 15 % glass fiber · EPDM · NBR · FKM		
Guide bushing	CrNi steel		
Balancing bellows and bellows seal	Stainless steel 1.4571		
Actuator	Type 2413		
Diaphragm cases	1.0332 <sup>1)</sup>		
Diaphragm	EPDM with fabric insert <sup>2)</sup> · FPM for oils · NBR · EPDM with PTFE protective facing		

<sup>1)</sup> In corrosion-resistant version (CrNi steel)

<sup>2)</sup> Standard version; see Special versions for others

**Installation**

Normally, the valve is installed with the actuator suspended downwards. Install pipelines horizontally with a slight downward slope on both sides of the valve for drainage of the condensate.

- The direction of flow must match the arrow on the valve body.
- Adapt the control line to the conditions on site. The control line is not included in the scope of delivery. A control line kit is available for tapping the pressure directly at the valve body (see Accessories).



For further details on installation refer to Mounting and Operating Instructions ► EB 2517.

**Accessories**

Included in the scope of delivery:

Screw joint with restriction for 3/8" control line.

**To be ordered separately:**

- Adapter G 1/4 to 1/4 NPT, various screw fittings
- **Control line kit** (optionally with or without compensation chamber) for direct attachment to the valve and actuator (pressure tapped directly at the valve body, for set points ≥ 12 psi/0.8 bar).
- **Compensation chamber** for condensation and to protect the operating diaphragm against extreme temperatures. A compensation chamber is required for liquids above 300 °F/150 °C as well as for steam.

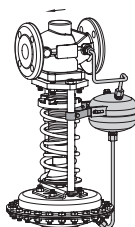

For detailed information on accessories refer to Data Sheet ► T 2595

**Ordering text**

**Type 41-73** Universal Excess Pressure Valve

Additional features ...

Valve size NPS/DN ...

Body material ...

Class/PN ...

K<sub>Vs</sub>/C<sub>v</sub> coefficient ...

Set point range ... psi/bar

Optionally, accessories ... (► T 2595)

Optionally, special version ...

**Dimensional drawings**

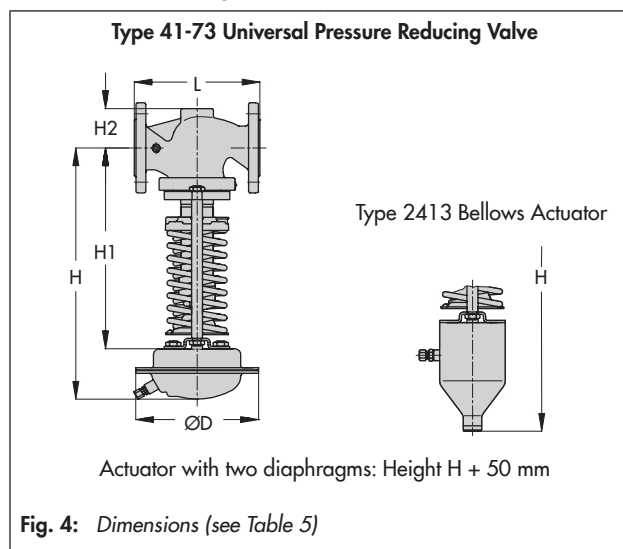

**Fig. 4:** Dimensions (see Table 5)

**Table 4:** Weights · Compensation chambers (standard version)

Order no.	Designation	Weight, approx.
1190-8788	Compensation chamber 0.7 l · Steel	1.6 kg
1190-8789	Compensation chamber 1.5 l · Steel	2.6 kg
1190-8790	Compensation chamber 2.4 l · Steel	3.7 kg

**Table 5: Dimensions and weights**

Type 41-73 Universal Excess Pressure Valve										
Valve size NPS/DN		1/2/15	3/4/20	1/25	1 1/2/40	2/50	2 1/2/65	3/80	4/100	
Length L	Class 125	Inch	–	–	7.25	8.75	10.0	10.87	11.75	13.87
		mm	–	–	184	222	254	276	298	352
	Class 150	Inch	7.25	7.25	7.25	8.75	10.0	10.87	11.73	13.88
		mm	184	184	184	222	254	276	298	352
	Class 300	Inch	7.50	7.63	7.75	9.25	10.50	11.50	12.50	14.50
		mm	190	194	197	235	267	292	318	368
Height H1	Inch	13.19			15.35		20.35		21.26	
	mm	335			390		517		540	
Height H2	Cast steel	Inch	1.7			2.83		3.86		4.65
		mm	44			72		98		118
	Forged steel	Inch	2.1	–	2.76	3.62	3.86	–	5.05	–
		mm	53	–	70	92	98	–	128	–
Set point ranges		Dimensions								
psi	bar	Dimension		Dimensions						
0.75 to 3.5	0.05 to 0.25	Height H		17.52"/445 mm		19.69"/500 mm		24.69"/627 mm		25.59"/650 mm
		Actuator		Ø D = 15.0"/380 mm, A = 100 in <sup>2</sup> /640 cm <sup>2</sup>						
		Valve spring force		1750 N						
1.5 to 8.5	0.1 to 0.6	Height H		17.52"/445 mm		19.69"/500 mm		24.69"/627 mm		25.59"/650 mm
		Actuator		Ø D = 15.0"/380 mm, A = 100 in <sup>2</sup> /640 cm <sup>2</sup>						
		Valve spring force		4400 N						
3.0 to 17	0.2 to 1.2	Height H		16.93"/430 mm		18.90"/480 mm		23.9"/607 mm		25.0"/635 mm
		Actuator		Ø D = 11.2"/285 mm, A = 50 in <sup>2</sup> /320 cm <sup>2</sup>						
		Valve spring force		4400 N						
10 to 35 <sup>2)</sup>	0.8 to 2.5 <sup>2)</sup>	Height H		16.93"/430 mm		19.09"/485 mm		24.1"/612 mm		25.0"/635 mm
		Actuator		Ø D = 8.86"/225 mm, A = 25 in <sup>2</sup> /160 cm <sup>2</sup>						
		Valve spring force		4400 N						
30 to 75	2.0 to 5.0	Height H		16.10"/410 mm		18.31"/465 mm		23.31"/592 mm		24.21"/615 mm
		Actuator		Ø D = 6.69"/170 mm, A = 12 in <sup>2</sup> /80 cm <sup>2</sup>						
		Valve spring force		4400 N						
65 to 145	4.5 to 10	Height H		16.10"/410 mm		18.31"/465 mm		23.31"/592 mm		24.21"/615 mm
		Actuator		Ø D = 6.69"/170 mm, A = 6 in <sup>2</sup> /40 cm <sup>2</sup>						
		Valve spring force		4400 N						
115 to 230	8.0 to 16	Height H		16.10"/410 mm		18.31"/465 mm		23.31"/592 mm		24.21"/615 mm
		Actuator		Ø D = 6.69"/170 mm, A = 6 in <sup>2</sup> /40 cm <sup>2</sup>						
		Valve spring force		8000 N						
Weight <sup>1)</sup> , approx.										
0.75 to 8.5	0.05 to 0.6	lb	51	53	73	80	121	130	158	
		kg	23	24	33	36	55	59	72	
3.0 to 35	0.2 to 2.5	lb	39	41	58	68	107	124	146	
		kg	18	19	26	31	49	56	66	
30 to 230	2.0 to 16	lb	29	32	51	58	97	114	136	
		kg	14	15	23	27	44	52	62	
Bellows actuator										
30 to 85	2.0 to 6.0	Height H		21.65"/550 mm		23.82"/605 mm		28.82"/732 mm		29.72"/755 mm
		Actuator		A = 9.6 in <sup>2</sup> /62 cm <sup>2</sup>						
		Valve spring force		4400 N						
75 to 145	5.0 to 10	Height H		21.65"/550 mm		23.82"/605 mm		28.82"/732 mm		29.72"/755 mm
		Actuator		A = 9.6 in <sup>2</sup> /62 cm <sup>2</sup>						
		Valve spring force		8000 N						
145 to 320	10 to 22	Height H		21.06"/535 mm		23.23"/590 mm		28.23"/717 mm		29.13"/740 mm
		Actuator		A = 5.1 in <sup>2</sup> /33 cm <sup>2</sup>						
		Valve spring force		8000 N						
300 to 400	20 to 28	Height H		21.06"/535 mm		23.23"/590 mm		28.23"/717 mm		29.13"/740 mm
		Actuator		A = 5.1 in <sup>2</sup> /33 cm <sup>2</sup>						
		Valve spring force		8000 N						
Weight <sup>1)</sup> , approx.										
A = 5.1 in <sup>2</sup> /33 cm <sup>2</sup>		lb	36	39	40	56	64	106	123	146
		kg	16.5	17.9	18	25.5	29	48	56	66
A = 9.6 in <sup>2</sup> /62 cm <sup>2</sup>		lb	46	47	49	65	73	119	143	165
		kg	20.9	21.5	22	29.5	33	54	65	75

<sup>1)</sup> Based on Class 150: +10 % for Class 300

<sup>2)</sup> Actuator with two diaphragms: 15 to 35 psi/1 to 2.5 bar

**Table 6:**  $C_V/K_{VS}$  coefficients and  $x_{FZ}$  values · Terms for noise level calculation according to VDMA 24422, edition 1.89

Valve size NPS	DN	Standard			Special version			With flow divider	
		$C_V^{1)}$	$K_{VS}^{1)}$	$x_{FZ}$	$C_V^{1)}$	$K_{VS}^{1)}$	$x_{FZ}$	$C_V\text{-ST 1}$	$K_{VS}\text{-ST 1}$
½	15				1.2	1.0	0.6		
		5.0	4.0	0.5				3.5	3.0
¾	20				1.2	1.0	0.6		
					5.0	4.0	0.5		
		7.5	6.3	0.45				6.0	5.0
1	25				1.2	1.0	0.6		
		9.4	8.0	0.4	5.0	4.0	0.5	7.0	6.0
1½	40				5.0 · 9.4	4.0 · 8.0	0.5 · 0.4		
		23	20	0.4				17	15
2	50				5.0 · 9.4	4.0 · 8.0	0.5 · 0.4		
		37	32	0.4				30	25
2½	65				37 <sup>2)</sup>	32 <sup>2)</sup>	0.4		
		60	50	0.4				45	38
3	80				37 <sup>2)</sup>	32 <sup>2)</sup>	0.4		
		94	80	0.35				49	42
4	100				94	80	0.4		
		145	125	0.35				77	66

<sup>1)</sup> With  $C_V \leq 5/K_{VS} \leq 4$ : without balancing bellows

<sup>2)</sup> Max. permissible differential pressure 360 psi/25 bar

### Valve-specific correction terms

–  $\Delta L_G$  · For gases and vapors: values according to Fig. 5

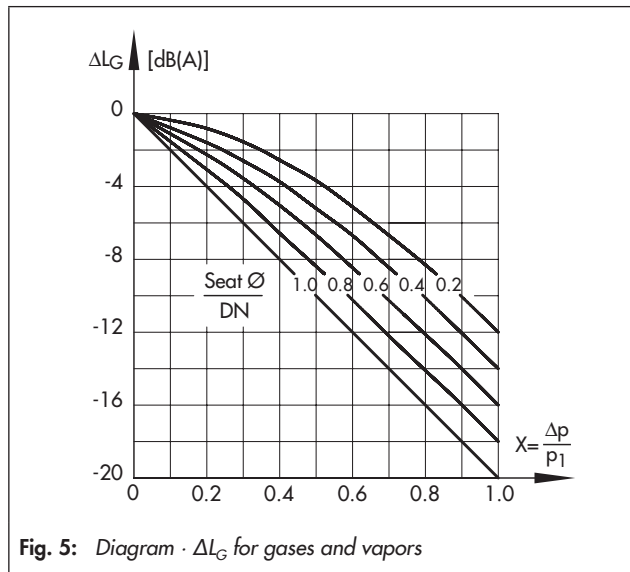

**Fig. 5:** Diagram ·  $\Delta L_G$  for gases and vapors

–  $\Delta L_F$  · For liquids:

$$\Delta L_F = -10 \cdot (x_F - x_{FZ}) \cdot y$$

$$\text{with } x_F = \frac{\Delta p}{p_1 - p_V} \text{ and } y = \frac{K_V}{K_{VS}}$$

Terms for control valve sizing according to IEC 60534, Parts 2-1 and 2-2:

- $F_L = 0.95$ ,  $X_T = 0.75$
- $x_{FZ}$  · Acoustical valve coefficient
- $C_V/K_{VS}\text{-ST 1}$  · When a flow divider ST 1 is installed as a noise-reducing component

Flow characteristic differences between valves with and valves without flow dividers do not occur until the valve has passed through approx. 80 % of its travel range.