

T 2540 EN**Type 2404-2 Excess Pressure Valve with Pilot Valve for small set point ranges**
Self-operated Pressure Regulators**Application**

Excess pressure valve for set points from **0.075 to 3 psi (5 to 200 mbar)** · Nominal size **NPS 2½ to 16 (DN 65 to 400)** · Pressure rating **Class 125, 150 and 300 (PN 16 to 40)** · Suitable for **gases** at temperatures from **-5 to +195 °F (-20 to +90 °C)**

The valve **opens** when the upstream pressure **rises**.

The pilot-operated Type 2404-2 Excess Pressure Valve is preferably used for the precise control of inert gas in tank blanketing applications (e.g. when storing oxidation-sensitive, toxic or explosive products). It regulates the excess pressure of the inert gas to a constant pressure within the millibar range.

The inert gas (usually nitrogen) is applied to protect the product inside the tank from reacting with the ambient atmosphere. In this way, the safe operation of tanks is achieved by allowing the tank to “breathe” in a controlled manner. Additional benefits include reduced pollution and inert gas costs.

The pressure regulator ensures that the blanketing pressure in the tank remains constant while the tank is being filled. Furthermore, adverse weather conditions, e.g. direct sunlight, can affect the pressure inside the tank. In this case, the excess pressure valve equalizes the tank pressure, resulting in stable pressure conditions.

Special features

- Low-maintenance proportional regulator
- Pilot control provides excellent control accuracy
- Internal set point springs
- Soft-seat plug provides bubble-tight shut-off performance
- Meets strict fugitive emission requirements
- Suitable for sour gas service (NACE)



Fig. 1: Type 2404-2 Excess Pressure Valve, NPS 16

Versions

The Type 2404-2 Excess Pressure Valve is a pilot-operated regulator. It consists of the following components:

Type 2406 as main valve

NPS 2½ to 6 (DN 65 to 150), balanced by a diaphragm
or

Type 2422 as main valve

NPS 8 to 16 (DN 200 to 400), balanced by a diaphragm,
with Type 2420 Actuator

- NPS 8 and 10 (DN 200 and 250): 320 cm²
- NPS 12 and 16 (DN 300 and 400): 640 cm²

Type 2406 Pilot Valve

½ NPT female thread, C_v 1.2 (K_{VS} 1)

Type 2441 Input Pressure Regulator

½ NPT female thread, C_v 1.2 (K_{VS} 1)

Mounting kit M2404, consisting of:

Hook-up, needle valve etc.

Special versions

Version with FDA-compliant materials for the food processing and pharmaceutical industries · Versions for sour gas service (NACE) · Actuator of pilot valve with seal and leakage line connection (e.g. for flammable gases)

Principle of operation

See Fig. 2

The Type 2404-2 Excess Pressure Valve is a pilot-operated regulator. It regulates the pressure of the inert gas upstream of the regulator within a very narrow mbar or psi range to a low pressure by opening when the pressure reaches the adjusted set point. This ensures that the blanketing gas (inert gas) is kept at a constant pressure level in the tank.

The following components interact to regulate the pressure of the inert gas.

The input pressure regulator (3) is delivered ready-adjusted. It reduces the supply pressure ¹⁾ p to the input pressure p_e for the pilot valve (2) to approx. 1 bar (positive pressure), ensuring precise pressure control even at varying upstream pressures.

The pilot valve (2) compares the actual pressure with the set point pressure. In the idle state, the pilot valve is closed by the force of the set point spring (2.1).

The upstream pressure p₁ to be controlled is routed to the pilot valve over the control line (2.4). The force of the upstream pressure p₁ at the operating diaphragm (2.2) is compared with the adjusted spring force of the set point spring. The pilot valve opens when the blanketing gas pressure in the tank rises above the adjusted set point. This causes the control pressure p_s to increase as well. The main valve also starts to open when the force of the control pressure p_s acting on the actuator diaphragm (1.2) in the main valve (1) is greater than the force of the closing spring (1.1). As a result, the blanketing gas is vented to the atmosphere or recovered for processing until the tank blanketing is re-stabilized or the pressure falls below adjusted set point. The needle valve (4) is delivered ready-adjusted and lead-sealed.

¹⁾ Medium for supply pressure p: compressed air or inert gas

Technical data

Table 1: Main valve

Type 2406 as main valve, balanced by a diaphragm					
Nominal size	NPS 2½ DN 65	NPS 3 DN 80	NPS 4 DN 100	- DN 125	NPS 6 DN 150
Pressure rating	Class 125, 150, 300 · PN 16, 40			Class 125, 150 · PN 16, 40	
C _v coefficients	60	94	145	-	450
K _{vS} coefficients	50	80	125	250	380
Actuator area	50 in ² · 320 cm ²				
Leakage class according to ANSI/FCI 70-2 or IEC 60534-4	Soft-seated, minimum Class IV				
Permissible differential pressure Δp	175 psi · 12 bar				
Perm. temperature	-5 to +195 °F · -20 to +90 °C ¹⁾				
Conformity	CE				
Type 2422 as main valve, balanced by a diaphragm, with Type 2420 Actuator					
Nominal size	NPS 8 DN 200	NPS 10 DN 250	NPS 12 DN 300	NPS 16 DN 400	
Pressure rating	Class 125, 150 · PN 16, 40				
C _v coefficients	760	930	1440	2400	
K _{vS} coefficients	650	800	1250	2000	
Actuator area of Type 2420	320 cm ²		640 cm ²		
Leakage class according to ANSI/FCI 70-2 or IEC 60534-4	Soft-seated, minimum Class IV				
Permissible differential pressure Δp	145 psi · 10 bar			90 psi · 6 bar	
Perm. temperature	-5 to +195 °F · -20 to +90 °C ¹⁾				
Conformity	CE				

¹⁾ Max. 175 °F (80 °C) for EPDM and NBR versions

Table 2: Pilot valve

Type 2406 Pilot Valve				
Connection	½ NPT female thread			
Pressure rating	Class 300			
C _v coefficient	1.2			
K _{vS} coefficient	1			
Set point ranges	0.075 to 0.2 psi 5 to 15 mbar	0.15 to 0.45 psi 10 to 30 mbar	0.35 to 0.9 psi 25 to 60 mbar	0.75 to 3 psi 50 to 200 mbar
Actuator area	100 in ² · 640 cm ²	50 in ² · 320 cm ²	50 in ² · 320 cm ²	50 in ² · 320 cm ²
Input pressure p _e	Fixed setting by input pressure regulator, min. 15 psi · min. 1 bar			
Perm. temperature	-5 to +195 °F · -20 to +90 °C ¹⁾			

¹⁾ Max. 175 °F (80 °C) for EPDM and NBR versions

Table 3: Materials · Material numbers according to ASTM and DIN EN

Type 2422 as main valve	
Body	A126B, A216 WCC, A351 CF8M · EN-GJL-250, 1.0619, 1.4408
Valve seat and plug	NPS 8 to 10 (DN 200 to 250): CF3M (1.4409) NPS 12 and 16 (DN 300 and 400): 304 or 410 (1.4301) ¹⁾
Plug seal	EPDM · NBR · FKM
Operating diaphragm, balancing diaphragm	EPDM · NBR · FKM ²⁾
Internal parts, guiding parts	1,440/4316L
Diaphragm cases	1.0332 (1.4301/stainless steel body)
Actuator springs	1.4310 ³⁾

¹⁾ NPS 12 and 16: optionally 1.4404/316L

²⁾ NPS 8, 10 and 12 (DN 200, 250 and 300) only

³⁾ Versions for sour gas service (NACE): Hastelloy®

Type 2406 as main valve	
Body	A126B, A216 WCC, A351 CF8M · EN-GJL-250, 1.0619, 1.4408
Valve seat	1.4404/316L
Plug	1.4404/316L
Plug seal	EPDM · NBR · FKM
Operating diaphragm, balancing diaphragm	EPDM · NBR ¹⁾ · FKM
Internal parts, guiding parts	1.4404/316L
Diaphragm cases	1.0332 (1.4301/stainless steel body)
Actuator springs	1.4310 ²⁾

¹⁾ Not for NPS 2½, 3 and 4 (DN 65, 80 and 100)

²⁾ Versions for sour gas service (NACE): Hastelloy®

Type 2406 Pilot Valve	
Pilot valve	Type 2406 ¹⁾
Body	A216 WCC · A351 CF8M
Valve seat	1.4404/316L
Plug	1.4404/316L
Plug seal	EPDM · NBR · FKM
Operating diaphragm	EPDM · FKM
Internal parts, guiding parts	1.4404/316L
Set point spring	1.4310
Mounting kit	
Piping	Stainless steel
NPT screw fittings	1.4404/316L
Needle valve	1.4404/316L
Input pressure regulator	1.4408/A351 CF8M

¹⁾ Versions for sour gas service (NACE) possible

Dimensions · NPS 2½ to 6 (DN 65 to 150)

Table 4: Dimensions · NPS 2½ to 6 (DN 65 to 150) (see Fig. 3 to Fig. 5)

Type 2404-2	NPS 2½ DN 65	NPS 3 DN 80	NPS 4 DN 100	- DN 125	NPS 6 DN 150
L1 Class 125 and 150	10.9"/276 mm	11.7"/298 mm	13.9"/352 mm	-	17.75"/451 mm
Class 300	11.5"/292 mm	12.5"/318 mm	14.5"/368 mm	-	-
L1 PN 16 and 40	11.4"/290 mm	12.2"/310 mm	13.8"/350 mm	15.75"/400 mm	18.9"/480 mm
L2 (approx.)	14.2"/360 mm				12.5"/317 mm
L3 (approx.)	9.4"/240 mm				8.3"/212 mm
ØD	5 to 15 mbar · 0.075 to 0.2 psi		Ø15"/380 mm, A = 100 in ² /640 cm ²		
	10 to 30 mbar · 0.15 to 0.45 psi		Ø11.2"/285 mm, A = 50 in ² /320 cm ²		
	25 to 60 mbar · 0.35 to 1.5 psi		Ø11.2"/285 mm, A = 50 in ² /320 cm ²		
	50 to 200 mbar · 0.75 to 3 psi		11.2"/285 mm		
H ¹⁾	EPDM · NBR	25.8"/655 mm	26.8"/680 mm	29"/735 mm	29.9"/760 mm
	FKM			30.9"/784 mm	31.9"/810 mm
H3	3.8"/98 mm	3.9"/100 mm	4.7"/120 mm	5.7"/145 mm	6.9"/175 mm
b (approx.)	9.9"/250 mm				
Weight, approx.	123 lb/56 kg	135 lb/61 kg	154 lb/70 kg	280 lb/127 kg	291 lb/132 kg

¹⁾ For 640 cm² actuator: height H +8 mm

Dimensions · DN 200 to 400 · NPS 8 to 16

Table 5: Dimensions · DN 200 to 400 · NPS 8 to 16 (see Fig. 6 and Fig. 7)

Type 2404-2		NPS 8 DN 200	NPS 10 DN 250	NPS 12 DN 300	NPS 16 DN 400
L1	Class 125 and 150	21.4"/543 mm	26.5"/673 mm	28.9"/736 mm	40"/1016 mm
L1	PN 16 and 40	18.9"/480 mm	23.6"/600 mm	28.7"/730 mm	33.5"/850 mm
L2 (approx.)		14.9"/378 mm		19.7"/500 mm	
L3 (approx.)		8.2"/208 mm		12.3"/313 mm	13.5"/343 mm
ØD	5 to 15 mbar · 0.075 to 0.2 psi	Ø15"/380 mm, A = 100 in ² /640 cm ²			
	10 to 30 mbar · 0.15 to 0.45 psi	Ø11.2"/285 mm, A = 50 in ² /320 cm ²			
	25 to 60 mbar · 0.35 to 1.5 psi	Ø11.2"/285 mm, A = 50 in ² /320 cm ²			
	50 to 200 mbar · 0.75 to 3 psi	Ø11.2"/285 mm, A = 50 in ² /320 cm ²			
H ¹⁾	EPDM · NBR	28.3"/720 mm	29.1"/738 mm	29.9"/758 mm	30.6"/778 mm
	FKM	30.9"/783 mm	31.7"/803 mm	32.5"/823 mm	-
H3		9.3"/235 mm	10.2"/260 mm	11.2"/285 mm	14.6"/370 mm
b (approx.)	50 in ² /320 cm ²	19.5"/495 mm	20.7"/525 mm	22.3"/567 mm	25.2"/641 mm
	100 in ² /640 cm ²	21.3"/542 mm	22.6"/573 mm	23.8"/605 mm	25.9"/658 mm
Weight, approx.		529 lb/240 kg	573 lb/260 kg	772 lb/350 kg	1477 lb/670 kg

¹⁾ For 640 cm² actuator: height H +8 mm

Dimensions

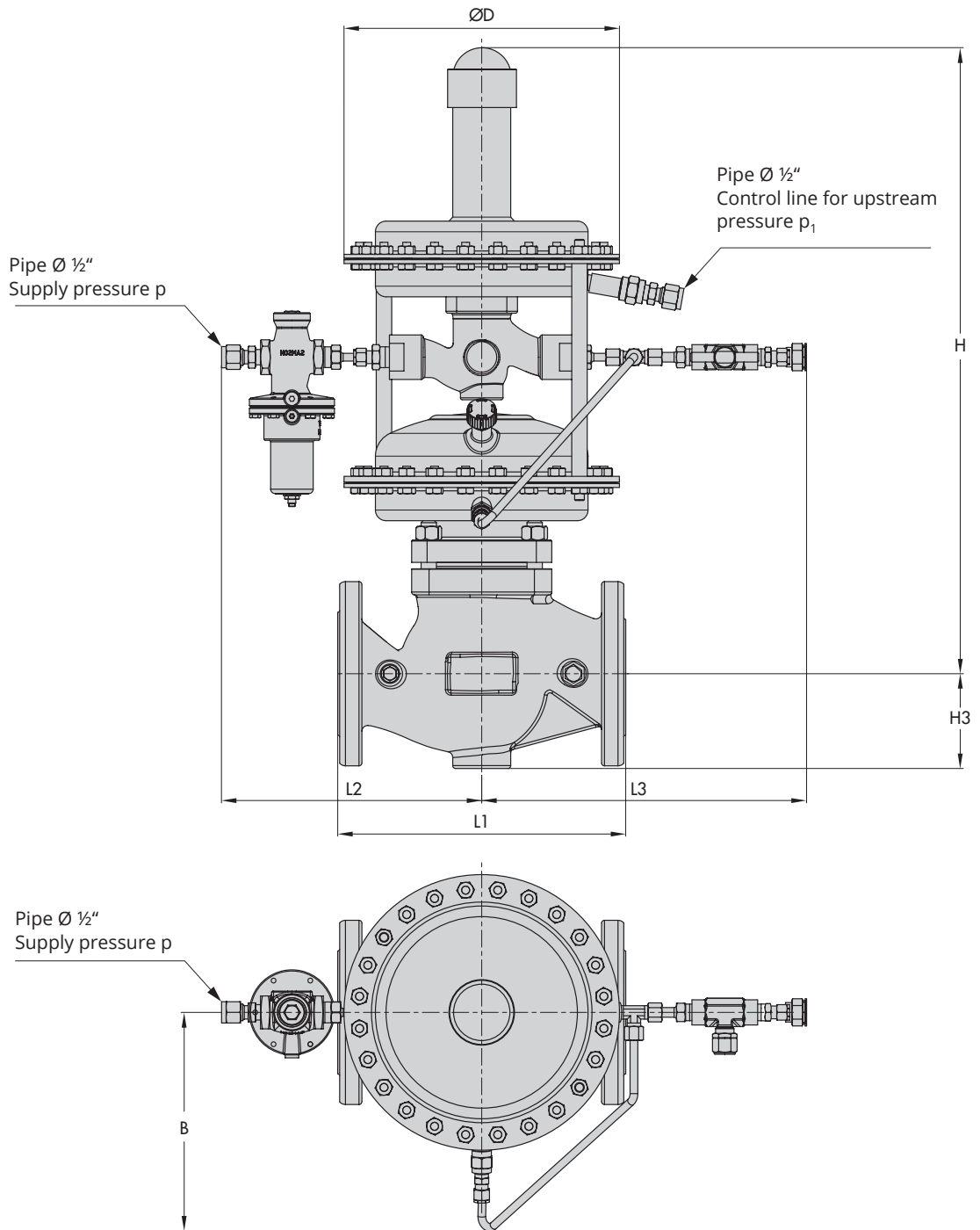

Fig. 3: Dimensions · DN 65 to 100 · NPS 2½ to 4 · Versions with seal/diaphragm made of EPDM/NBR/FKM

Dimensions

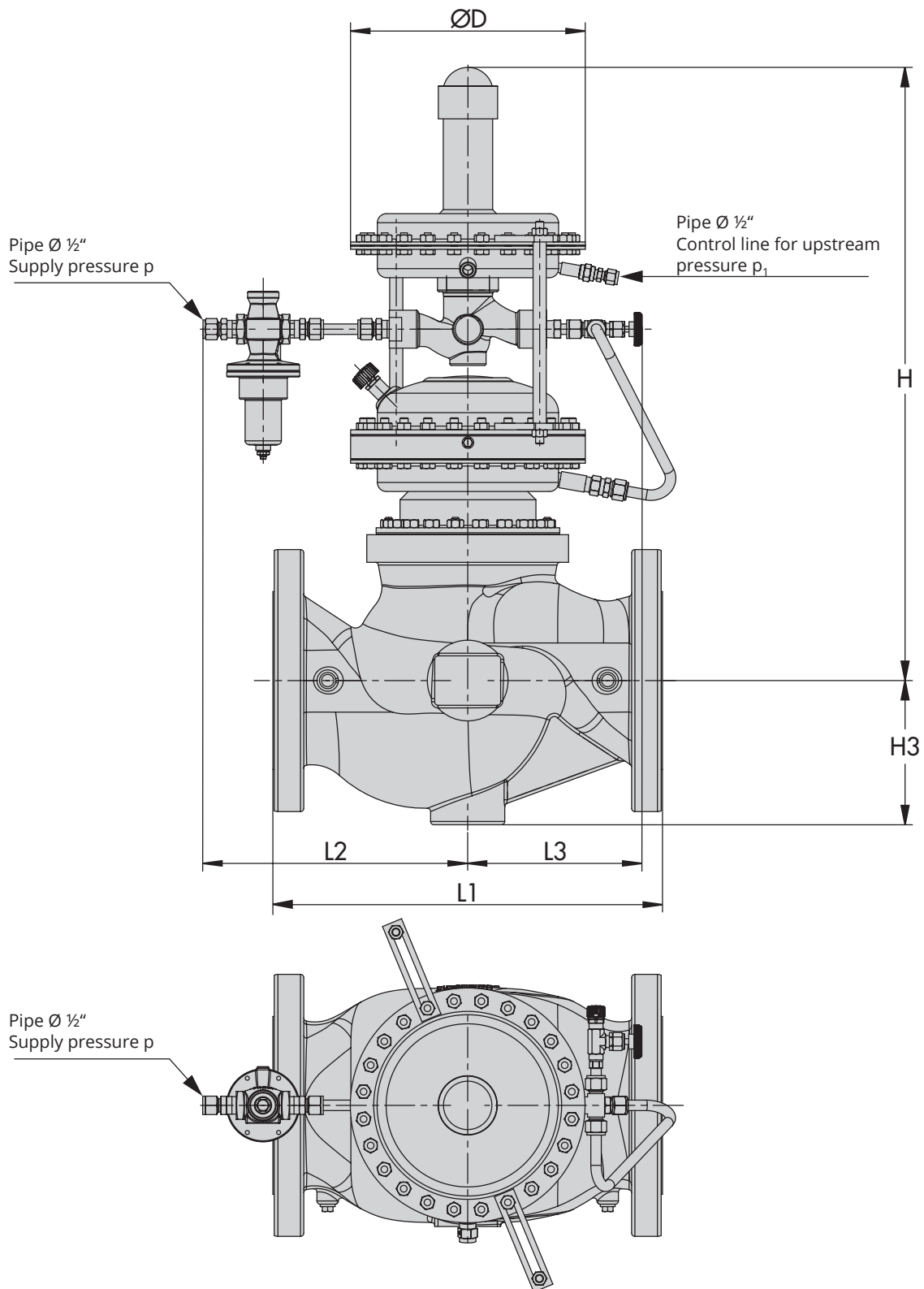

Fig. 4: Dimensions · DN 125 to 150 · NPS 6 · Versions with seal/diaphragm made of EPDM/NBR

Dimensions

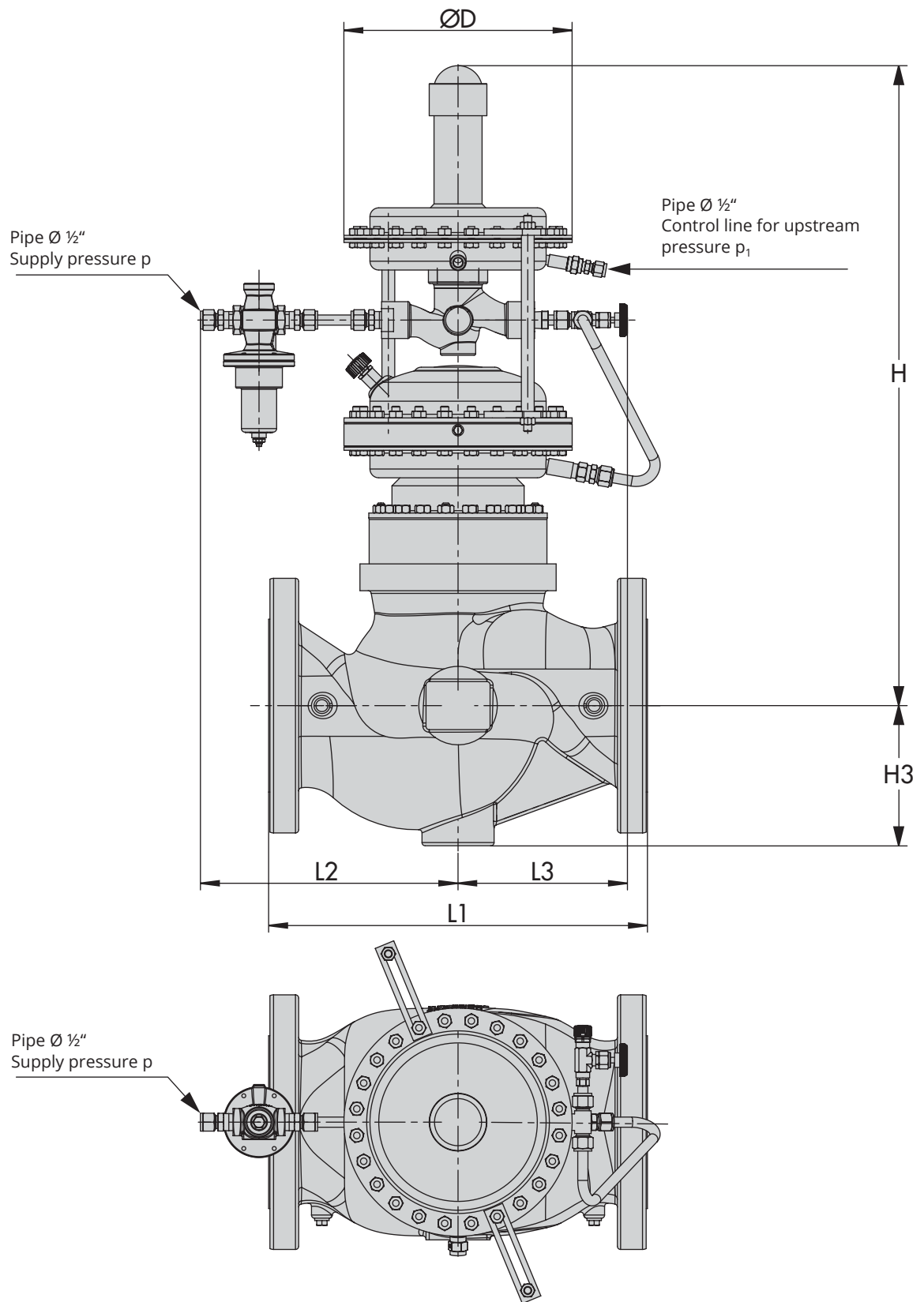

Fig. 5: Dimensions · DN 125 to 150 · NPS 6 · Versions with seal/diaphragm made of FKM

Dimensions

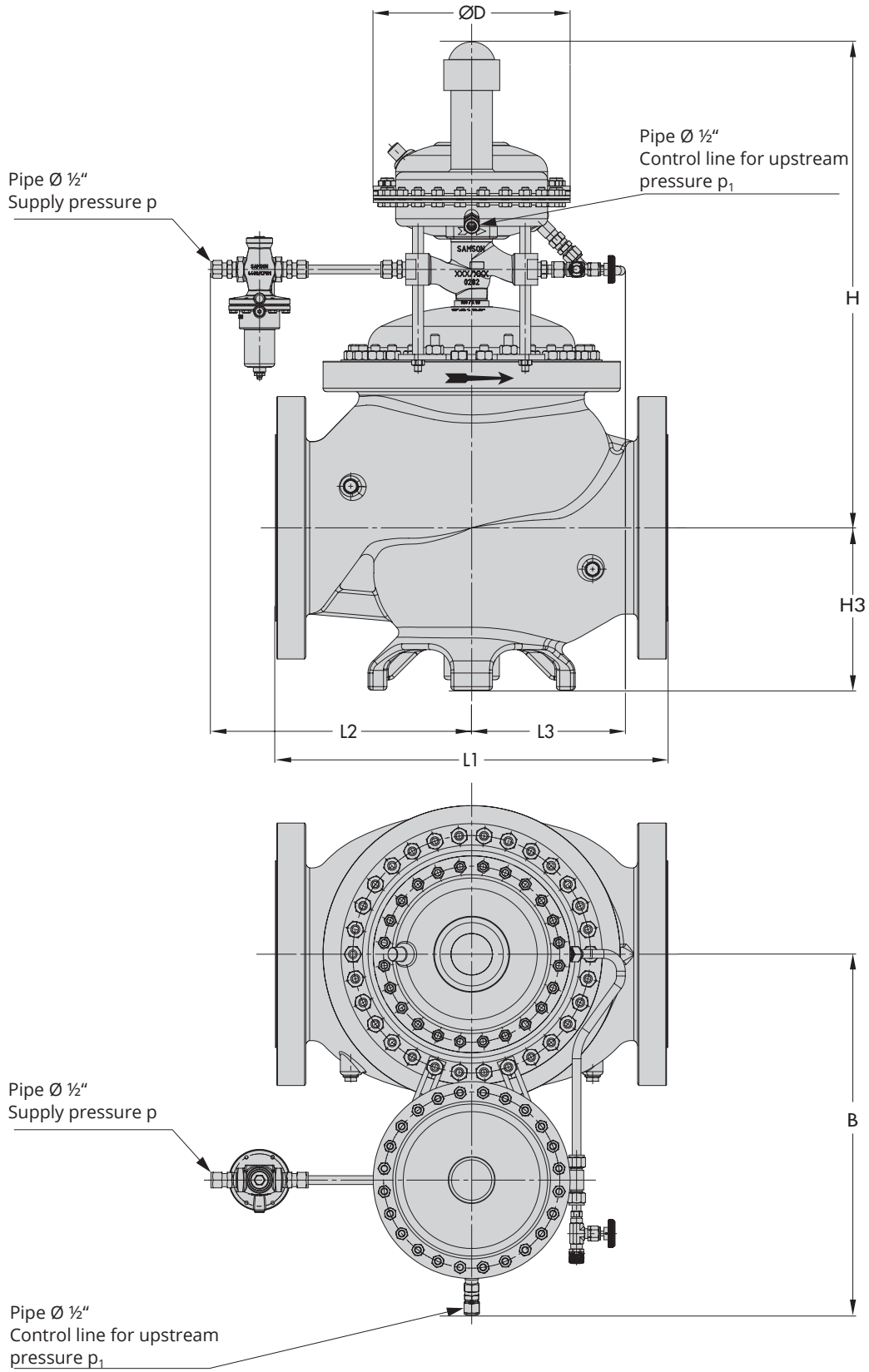

Fig. 6: Dimensions · DN 200 to 400 · NPS 8 to 16 · Versions with seal/diaphragm made of EPDM/NBR

Dimensions

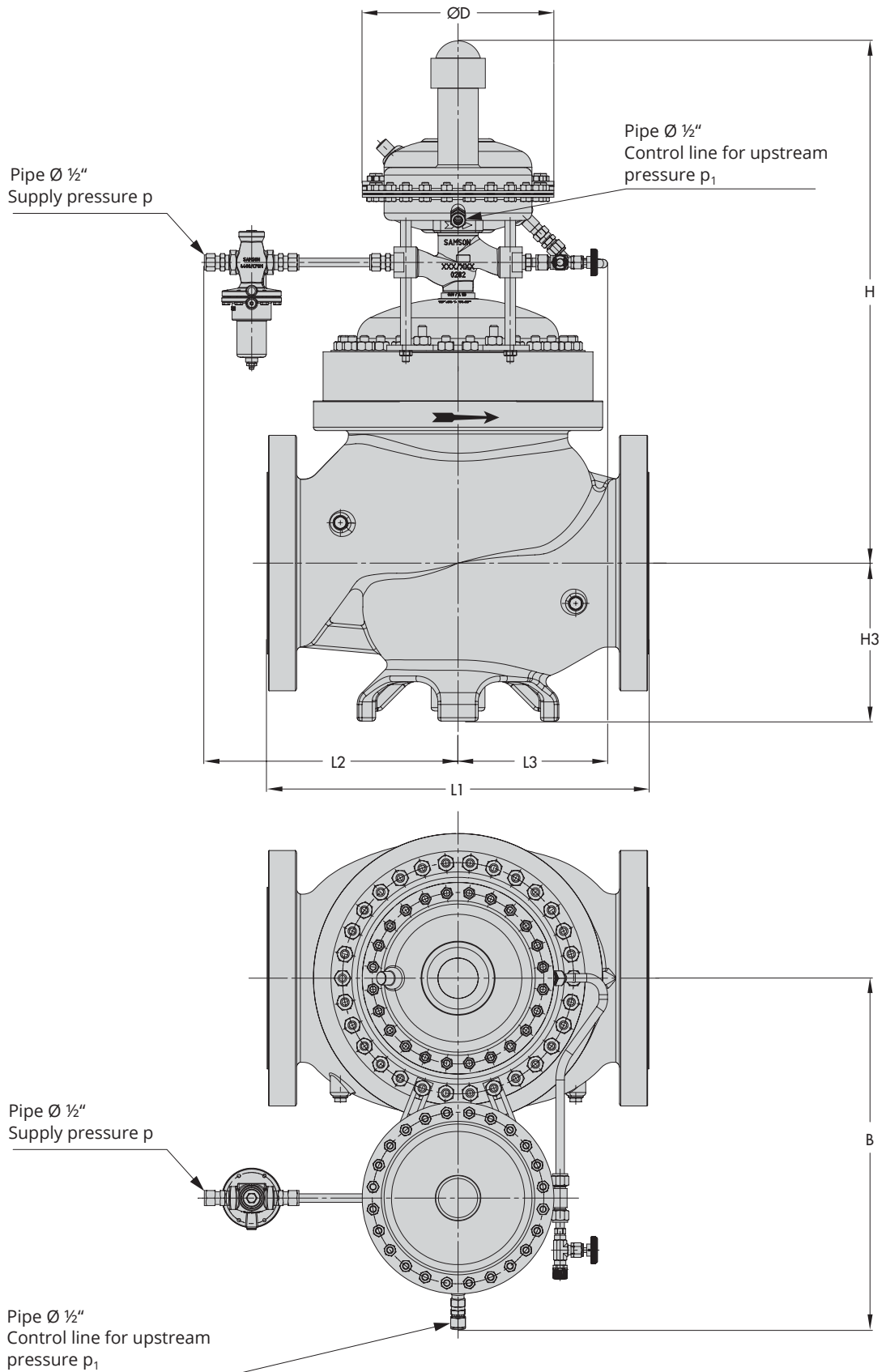

Fig. 7: Dimensions · DN 200 to 300 · NPS 8 to 12 · Versions with seal/diaphragm made of FKM

Installation

The regulator is delivered as a ready-to-install unit.

- Install the main valve in the pipeline at the site of installation and connect the control line (inert gas pressure p_1) to the pilot valve (pipe $\varnothing \frac{1}{2}$ ").
- Connect the line for the supply pressure p to the input pressure regulator (pipe $\varnothing \frac{1}{2}$ ").



Install the regulator in such a way that it is still easily accessible after the plant is completed to facilitate maintenance or revision work. Allow enough space for set point adjustment at the pilot valve using a socket wrench.

The following points must be observed:

- Installation in horizontal pipelines
- Install the valve assembly with the pilot valve pointing up
- The direction of flow must match the arrow on the body of the main valve

Further details can be found in ► EB 2540.

Ordering text

Type 2404-2 Excess Pressure Valve consisting of:

Type 2406 or Type 2422 Valve as main valve

Body material ...

Material: diaphragm ..., plug stem ...

NPS (DN) ..., C_v (K_{VS}) coefficient ...

Type 2406 Pilot Valve

Set point range 0.075 to 0.2 psi · 0.15 to 0.45 psi · 0.35

to 0.9 psi · 0.75 to 3 psi

(5 to 15 mbar · 10 to 30 mbar · 25 to 60 mbar · 50 to

200 mbar)

Type 2441 Input Pressure Regulator, mounting unit

M2404