

T 2557-1 EN

Type 2357-1 Pressure Regulator

Self-operated Pressure Regulators for special applications



Application

Pressure regulators for cryogenic gases as well as other liquids, gases and vapors · Operating pressures **up to 50 bar** · Set point ranges from **0.2 to 40 bar** · Temperatures from **-196 to +200 °C** · Oxygen clean according to international standards and guidelines

Pressure build-up regulator: The valve **opens** when the upstream pressure **drops**

Pressure reducing valve: The valve **closes** when the downstream pressure **rises**

Industrial gases (such as argon, nitrogen and oxygen) are stored in a liquefied condition at extremely low temperatures and at a constant pressure in thermally insulated tanks. Pipes transport the medium to the consumer. The extreme operating conditions (pressures up to 50 bar and temperatures down to -196 °C) make it necessary to use special valves.

The Series 2357 Pressure Regulators are especially designed for the conditions in cryogenic service. These regulators can also be used for gases, liquids and vapors under other operating conditions.

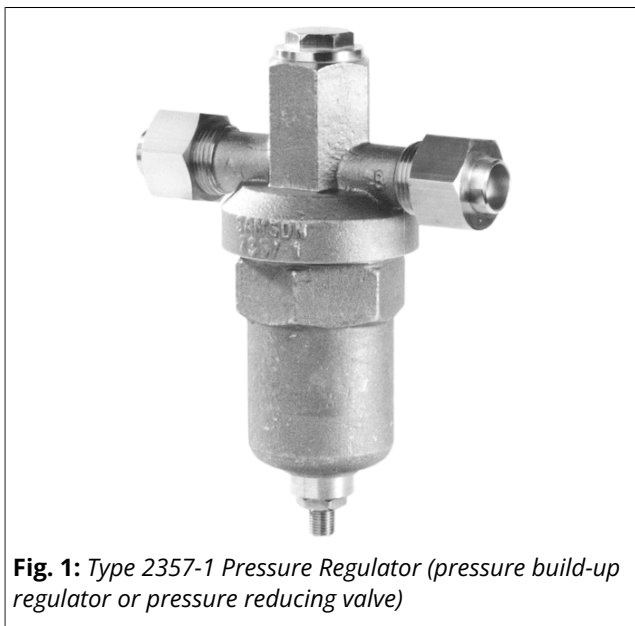

Fig. 1: Type 2357-1 Pressure Regulator (pressure build-up regulator or pressure reducing valve)

Special features

- Low-maintenance proportional regulators requiring no auxiliary energy
- Wide set point range and convenient set point adjustment
- Rugged design and low overall height
- Cleaned and packed for oxygen service

Versions

The pressure regulators consist of a valve body with two ports (marked A and B), internal operating diaphragm and set point adjuster.

Pressure reduction function

– **Type 2357-1 Pressure Build-up Regulator with safety function**

The upstream pressure is transmitted to the operating diaphragm. The valve opens when the upstream pressure drops. Direction of flow from port B to port A.

– **Type 2357-1 Pressure Reducing Valve with safety function**

Pressure regulator (globe valve). The valve regulates the downstream pressure to the adjusted set point. The valve closes when the downstream pressure rises. Direction of flow from port A to port B.

– **Safety function of Type 2357-1**

The plug in the pressure build-up regulator or pressure reducing valve relieves the pressure chamber at port B. The pressure acts from below against the plug surface. The valve opens to equalize the pressures.

Accessories

For Type 2357-1

- Solder nipple with ball-type bushing (for connection to 16 or 15 mm pipe diameter); filter with 270 µm mesh

Further accessories in Data Sheet ► T 2570.

Principle of operation

Functioning as a **pressure build-up regulator** with direction of flow from port B to port A, the pressure upstream of the valve (port B) is transmitted to the operating diaphragm. The valve closes when the upstream pressure increases and opens when the upstream pressure drops.

The safety function of the pressure build-up regulator relieves the pressure chamber of pressure when the pressure exceeds the set point by more than 5 bar. After overcoming the spring force of the top springs (16), the valve opens to equalize the pressures.

The process medium flows from port A to port B when the Type 2357-1 Pressure Regulator is used as **pressure reducing valve**.

The valve is open when no pressure is applied. The pressure downstream of the valve (port B) is transmitted to the operating diaphragm (3). The positioning force produced moves the valve plug (2.1) depending on the spring force adjustable at the set point adjuster (10). The valve closes when the pressure downstream of the valve (port B) rises.

The safety function of the pressure reducing valve relieves the pressure chamber of pressure when the pressure exceeds the set point by more than 5 bar. The resulting downstream pressure is 5 bar below the upstream pressure.

Installation

Mounting position with the spring housing suspended downward · Other mounting positions on request.

- **Build-up pressure regulator with safety function**

Direction of flow from port B to port A

- **Pressure reducing valve**

Direction of flow from port A to port B

Further information can be found in the Mounting and Operating Instructions ► EB 2557.

EC type examination

An EC type examination according to the Pressure Equipment Directive 2014/68/EU, Module B has been performed on the Type 2357-1 Regulator.

Serial number

The devices are marked with a serial number on the nameplate. Details on the nameplate are available in the Mounting and Operating Instructions ► EB 2557.

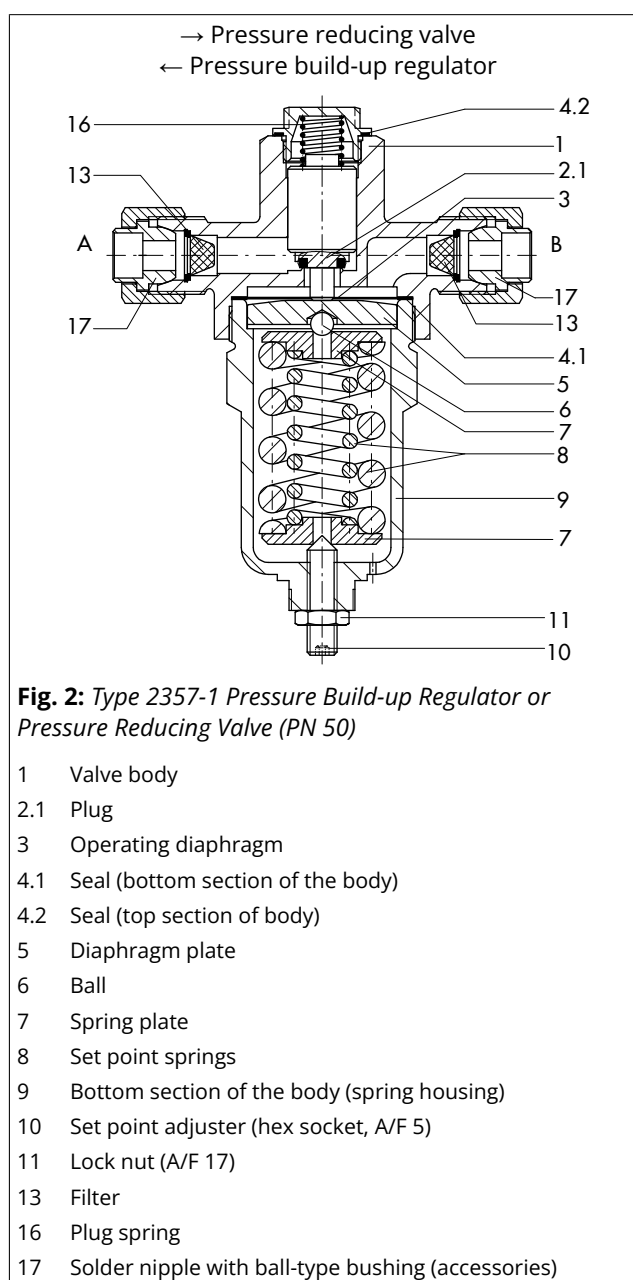

Installation example

See Fig. 3

Pressure regulator functioning as a pressure build-up regulator with safety function

When tapping the liquefied cryogenic gas, the gas pressure in the insulated tank causes the medium to be transferred to the vaporizer (8). The gas pressure in the tank drops below the adjusted operating pressure. The Type 2357-1 Regulator (in-

stalled as a pressure build-up regulator; 2) opens and allows the liquefied gas to flow into the pressure build-up vaporizer (7). The gas pressure increases and reaches the operating pressure again. The pressure build-up regulator (2) closes.

After closing the shut-off valve (6.1), the liquid remaining in the pipeline between shut-off valve (6.1) and regulator (2) vaporizes, causing the pressure to increase. The plug of the pressure build-up regulator (2) acts as safety valve by opening the valve (upstream pressure at port B) to equalize the pressures. The pressure chamber is relieved of pressure as a result.

Pressure regulator functioning as a pressure reducing valve

If a lower pressure is required in the draw-off pipe, the Type 2357-1 Pressure Regulator can be used to function as a pressure reducing valve (4).

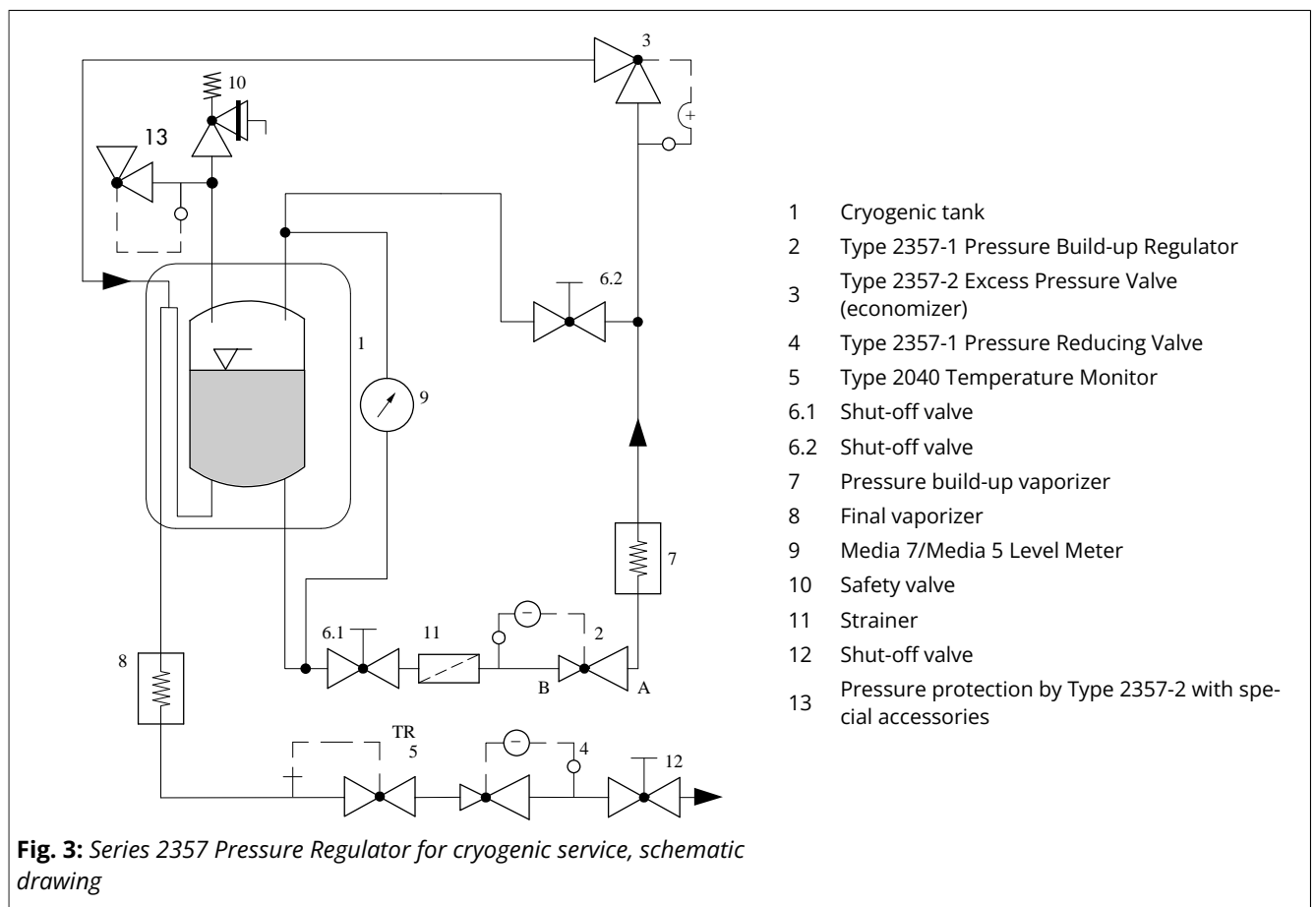



Table 1: Technical data · All pressures in bar (gauge)

Type	2357-1	
Pressure rating	PN 40	PN 50 ²⁾
K _{V5} coefficient	0.25	0.8
Set point range ¹⁾ in bar	1 to 25 · 10 to 36	0.2 to 2.5 · 1 to 8 · 5 to 25 · 8 to 40
Max. perm. differential pressure Δp	Gases: 30 bar · Liquids: 6 bar	
Safety function for Type 2357-1	5 bar above the set point	

Type	2357-1
Temperature range	-196 to +200 °C
Weight, approx.	3.5 kg
Conformity	

1) Further set point ranges on request

2) For oxygen $p_{\max} = 40$ bar

Table 2: Materials · Material numbers according to DIN EN

Type	2357-1
Body	CC754S-GM (brass) ¹⁾
Cover	CC754S-GM (brass) ¹⁾
Plug	CW602N (brass) ¹⁾ with PTFE soft seal
Operating diaphragm	CuBe
Set point springs	Stainless steel 1.4310
Body gasket	PTFE

¹⁾ PN 40: CW617N (brass)

Table 3: Type 2357-1 · Valve version and end connections

Design	Version	End connections	
		Inlet	Outlet
Pressure build-up regulator/pressure reducing valve ¹⁾	Globe valve	G ¾ A (conical joint)	

¹⁾ G ¾ A (conical joint) PN 50 only

Dimensions (in mm)

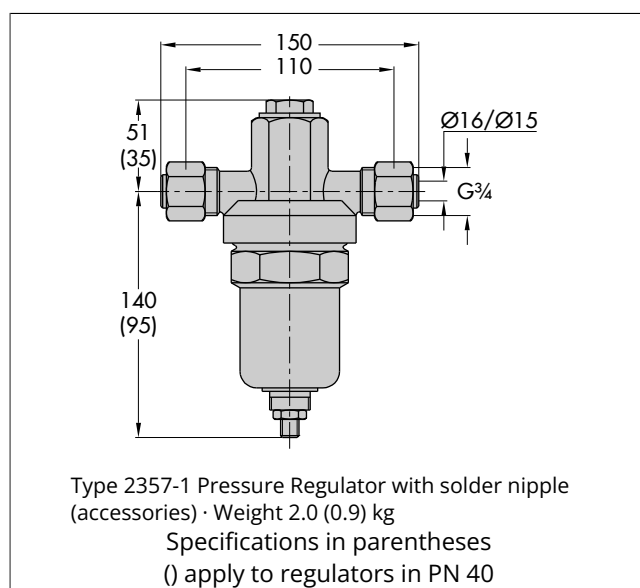

Flow capacity of the regulator dependent on the liquid column in the cryogenic tank

The flow capacity is indicated separately in value tables and mass flow diagrams for the media nitrogen (N₂), oxygen (O₂), argon (Ar), carbon dioxide (CO₂) and natural gas (LNG).

The specifications apply to the **Type 2357-1** Pressure Build-up Regulator installed in the liquid phase of the pressure build-up control loop; as shown in Fig. 3 (**Sample application**). The maximum flow capacity [kg/h] of the regulator arises from the liquid level of the medium in the tank and can be determined from the graph.

The data in the graph are based on theoretical calculations which do not take factors, such as pressure losses in the pipeline, into account. Therefore, the real flow capacity may deviate from the calculated value.

Table 4: Mass flow of various media dependent on the liquid column in the cryogenic tank

Filling level in m	Process medium				
	N ₂	O ₂	Ar	CO ₂	LNG
	Mass flow rate in kg/h				
1	248	351	427	359	130
3	379	537	653	550	199
5	475	673	819	689	249
7	555	785	956	805	291
9	624	884	1076	906	328
11	687	973	1184	996	361
14	771	1093	1329	1119	405
17	848	1201	1460	1230	445
20	918	1300	1580	1331	482

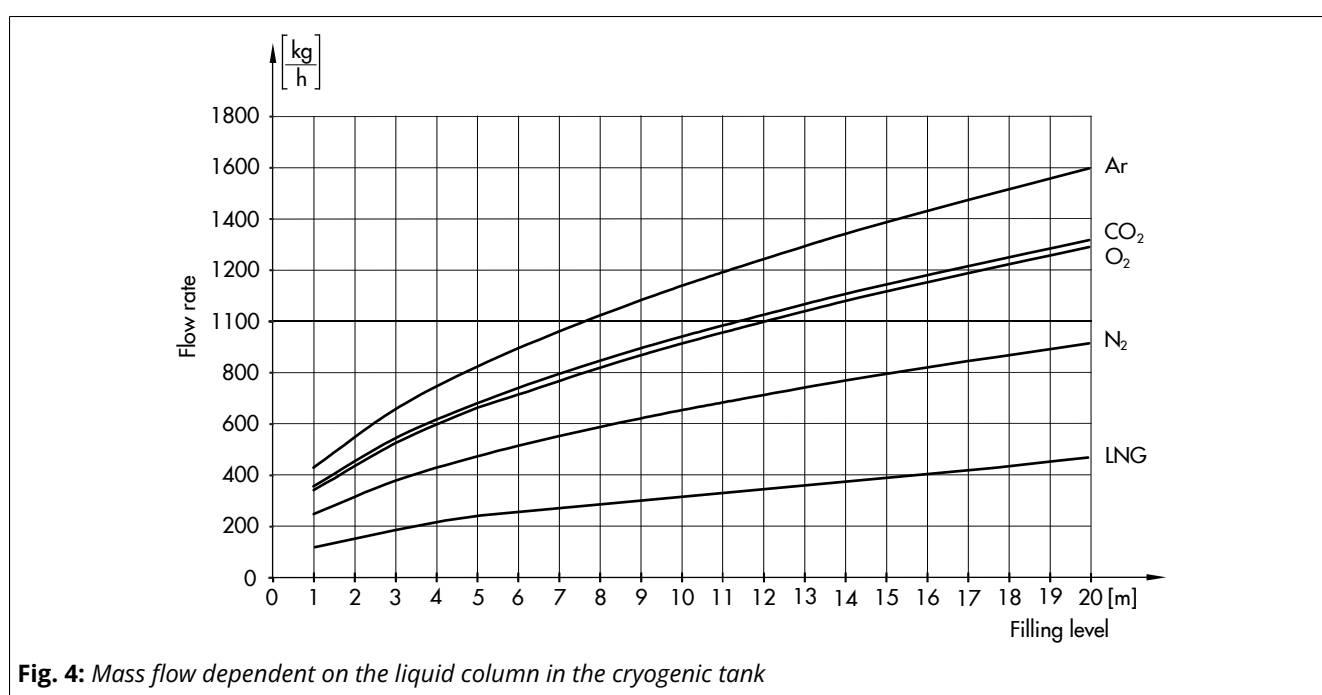

Fig. 4: Mass flow dependent on the liquid column in the cryogenic tank

Ordering text

Type 2357-1 Pressure Reducing Valve or Pressure Build-up Regulator
 Set point range ... bar
 Optionally, accessories ...
 Optionally, special version ...