

## T 2623 EN

### Type 2442 (Type 44-2) Pressure Reducing Valve Type 2443 (Type 44-3) Safety Shut-off Valve (SSV) with Pressure Reducing Valve Series 44 Self-operated Pressure Regulators

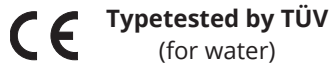

#### Application

Pressure regulators for set points **from 0.5 to 10.5 bar** · Valves in **DN 15 to 50 · PN 25** · Suitable for liquids up to **150 °C**, air and nitrogen up to **80 °C** · Safety shut-off valve (SSV) with pressure reducing valve for protecting district heating plants

The valve **closes** when the **downstream** pressure rises.

The **Type 2442 (Type 44-2) Pressure Reducing Valve** consists of a valve and an actuator with operating diaphragm.

The **Type 2443 (Type 44-3) Safety Shut-off Valve (SSV)** with integrated pressure reducing valve is equipped with an actuator with two diaphragms. The version with two independent operating diaphragm complies with AGFW (German District Heating Association) regulations concerning components in district heating systems. This regulator version continues to operate even after the operating diaphragm ruptures.

In the event of a ruptured operating diaphragm in the actuator, the regulator continues to operate. An indicator at the actuator shows that the actuator is damaged.

#### Special features

- Suitable for air, nitrogen, water and other liquids, provided these do not cause the materials used to corrode.
- Single-seated valve with balanced plug
- The regulators comply with requirements of FW 504 published by AGFW (German District Heating Association).

#### Versions (see Fig. 2 and Fig. 3)

Series 44 Pressure Regulators with actuators for set point ranges from 0.5 to 10.5 bar · Nominal sizes DN 15 to 50 · With welding ends (special version with threaded ends) · DN 32, 40 and 50 versions also available with flanged valve body

**Type 2442** Pressure Reducing Valve with one operating diaphragm

**Type 2443** Safety Shut-off Valve (SSV) with pressure reducing valve and two operating diaphragms. In the event of a ruptured operating diaphragm in the actuator, the regulator continues to operate. · **Typetested according to AGFW document FW 504**

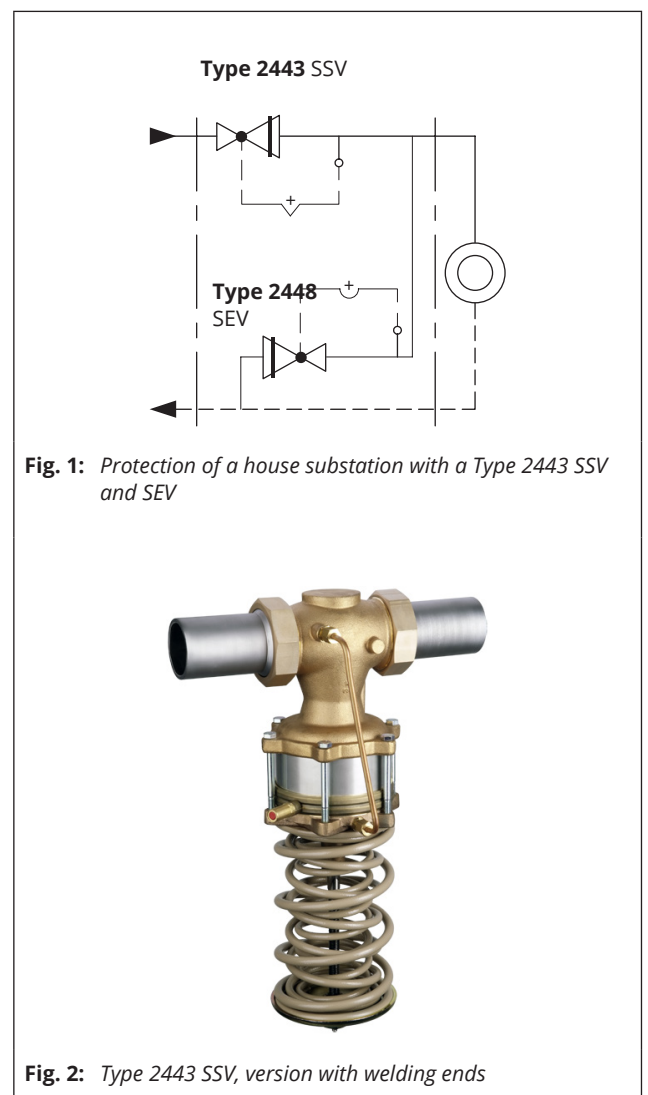

### Special version

- Restricted flow cross-section with lower  $K_{VS}$  coefficient for DN 15, 20 and 25.
- With internal parts made of FKM, e.g. for use with mineral oils

### Principle of operation

The medium flows through the valve (1) as indicated by the arrow. The position of the plug determines the flow rate across the area released between plug (3) and seat (2).

The downstream pressure  $p_2$  to be controlled is transmitted over the external control line (11) to the operating diaphragm (6.1) where it is converted into a positioning force. This force is used to move the valve plug according to the force of the spring assembly (8). The spring force can be adjusted at the set point adjuster (10).

The valve closes when the downstream pressure rises and opens again when this pressure drops.

The valve has a balanced plug (3). As a result, the forces generated by the upstream pressure which act on the valve plug are eliminated.

In the event that the operating diaphragm (6.1) ruptures, the Type 2443 Safety Shut-off Valve (SSV) with pressure reducing valve continues to function since the backup diaphragm (6.2) takes over the control task.

To recognize a ruptured diaphragm, a diaphragm rupture indicator (12) is installed in the intermediate ring or optionally, a pressure switch can be used to issue a signal, e.g., to a control room.

### Type test

The **Type 2443** Safety Shut-off Valve (SSV) with pressure reducing valve for  $K_{VS}$  1.0 and higher has been type tested for water by the German technical surveillance association TÜV. The test mark is available on request.

### Installation

Install the regulator in horizontal pipelines.

The following points must be observed:

- The direction of flow must match the direction indicated by the arrow on the body
- The actuator must be suspended downwards.



Further details can be found in ► EB 2623-1 and ► EB 2623-2.

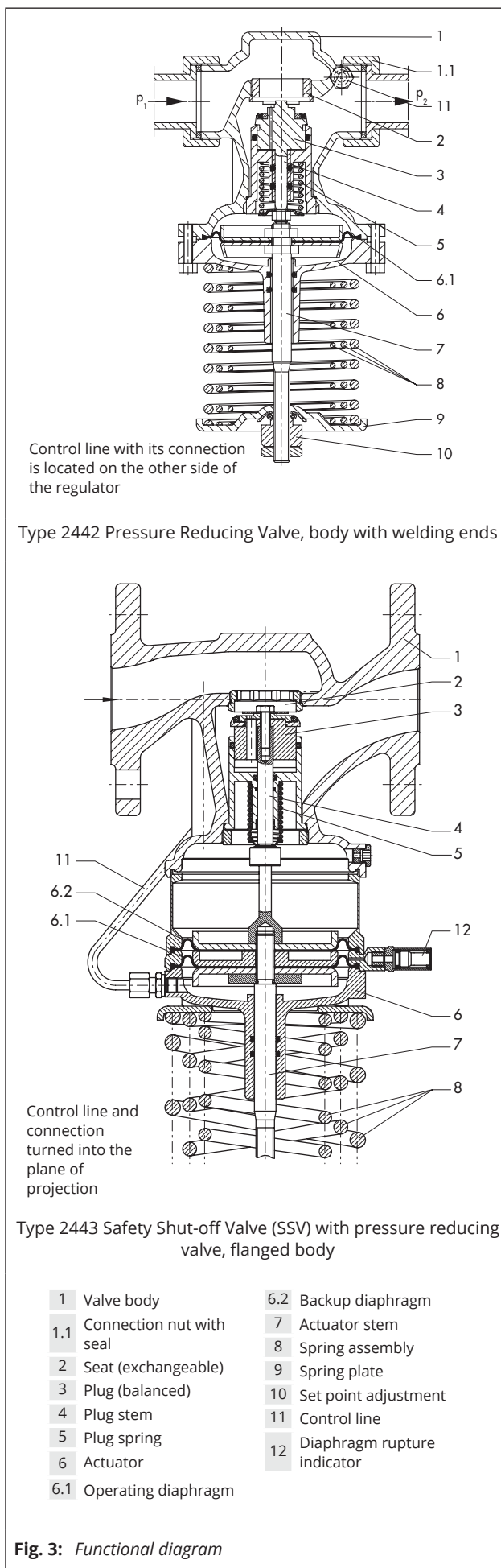

Fig. 3: Functional diagram

**Table 1: Technical data · All pressures in bar (gauge)**

| Nominal size   | DN               | 15  | 20  | 25   | 32                  | 40     | 50   |
|--|------------------|---|-----|------|---------------------|--------|------|
| K <sub>VS</sub> coefficient                              | Standard version | 4.0   | 6.3 | 8.0  | 12.5                | 16.0   | 20.0 |
|  | Special version  | 0.4 <sup>3)</sup> · 1.0 · 2.5   |     |      | 5.0 <sup>3)5)</sup> | -      | -    |
|  | Flanged body     | -   |     |      | 12.5                | 20.0   | 25.0 |
| x <sub>Fz</sub> value                                    |                  | 0.60  |     | 0.55 |                     | 0.50   | 0.45 |
| Pressure rating  |                  | PN 25   |     |      |                     |        |      |
| Max. perm. differential pressure Δp                      |                  | 20 bar  |     |      |                     | 12 bar |      |
| Max. permissible temperature                             |                  | 150 °C · 80 °C <sup>1)</sup>  |     |      |                     |        |      |
| Leakage class according to IEC 60534-4 (Type 2442)       |                  | ≤0.05 % of K <sub>VS</sub> coefficient                                    |     |      |                     |        |      |
| Set point ranges <sup>2)</sup> , continuously adjustable | Type 2442        | 0.5 to 2 bar · 1 to 4 bar · 2 to 4.2 bar · 2.4 to 6.3 bar · 6 to 10.5 bar |     |      |                     |        |      |
|  | Type 2443 (SSV)  | 1 to 4 bar <sup>3)</sup> · 2 to 4.2 bar · 2.4 to 6.3 bar · 6 to 10.5 bar  |     |      |                     |        |      |
| Max. permissible pressure at diaphragm actuator          |                  | 1 bar above the closing point adjusted at the valve <sup>4)</sup>         |     |      |                     |        |      |
| Conformity   |                  | <b>CE</b>   |     |      |                     |        |      |

<sup>1)</sup> With air and nitrogen

<sup>2)</sup> Special set point ranges on request

<sup>3)</sup> Special version (Type 2442 only)

<sup>4)</sup> To be protected by a downstream (safety) excess pressure valve

<sup>5)</sup> Balanced by a bellows

**Table 2: Materials · Material numbers according to DIN EN**

| Type 2442 and Type 2443 (SSV) Pressure Regulators |  |
|---|--|
| Valve body  | Red brass CC499K · Spheroidal graphite iron EN-GJS-400-18-LT <sup>1)</sup> |
| Actuator housing/intermediate ring                | Red brass CC499K   |
| Seat  | Stainless steel 1.4305   |
| Plug <sup>3)</sup>                                | Brass CW602N and stainless steel 1.4305 with EPDM soft seal <sup>2)</sup>  |
| Valve spring                                      | Stainless steel 1.4310   |
| Operating diaphragm                               | EPDM with fabric reinforcement <sup>2)</sup>                               |
| Seals   | EPDM <sup>2)</sup>   |

<sup>6)</sup> Additional version in DN 32, 40 and 50: valve with flanged body made of spheroidal graphite iron EN-GJS-400-18-LT

<sup>7)</sup> Special version, e.g. for mineral oils: FKM

<sup>8)</sup> K<sub>VS</sub> 0.4: stainless steel 1.4305

### Flow rate diagram for water

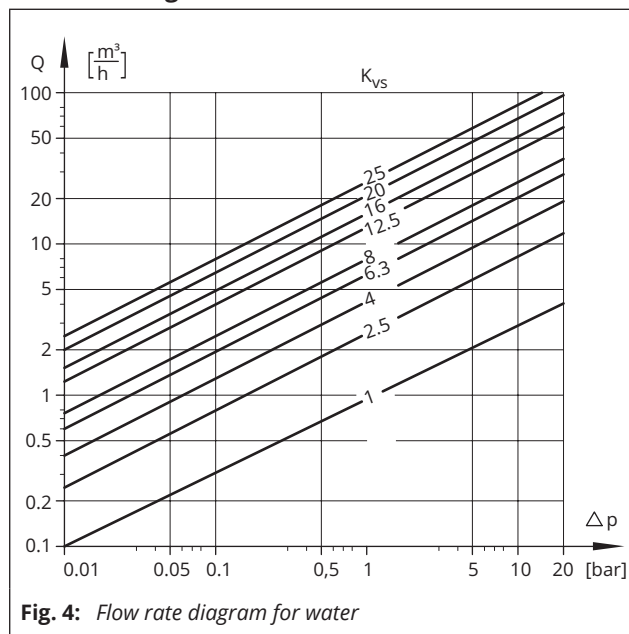

**Fig. 4:** Flow rate diagram for water

### Ordering text

**Type 2442** · Pressure reducing valve

DN ... with welding ends, threaded ends or with flanged body (DN 32, 40 and 50 only)

Set point range ... bar

Optionally, special version ...

**Type 2443** · Safety shut-off valve (SSV) with pressure reducing valve

DN ... with welding ends, threaded ends or with flanged body (DN 32, 40 and 50 only)

Set point range ... bar

Optionally, special version ...

## Dimensional drawings

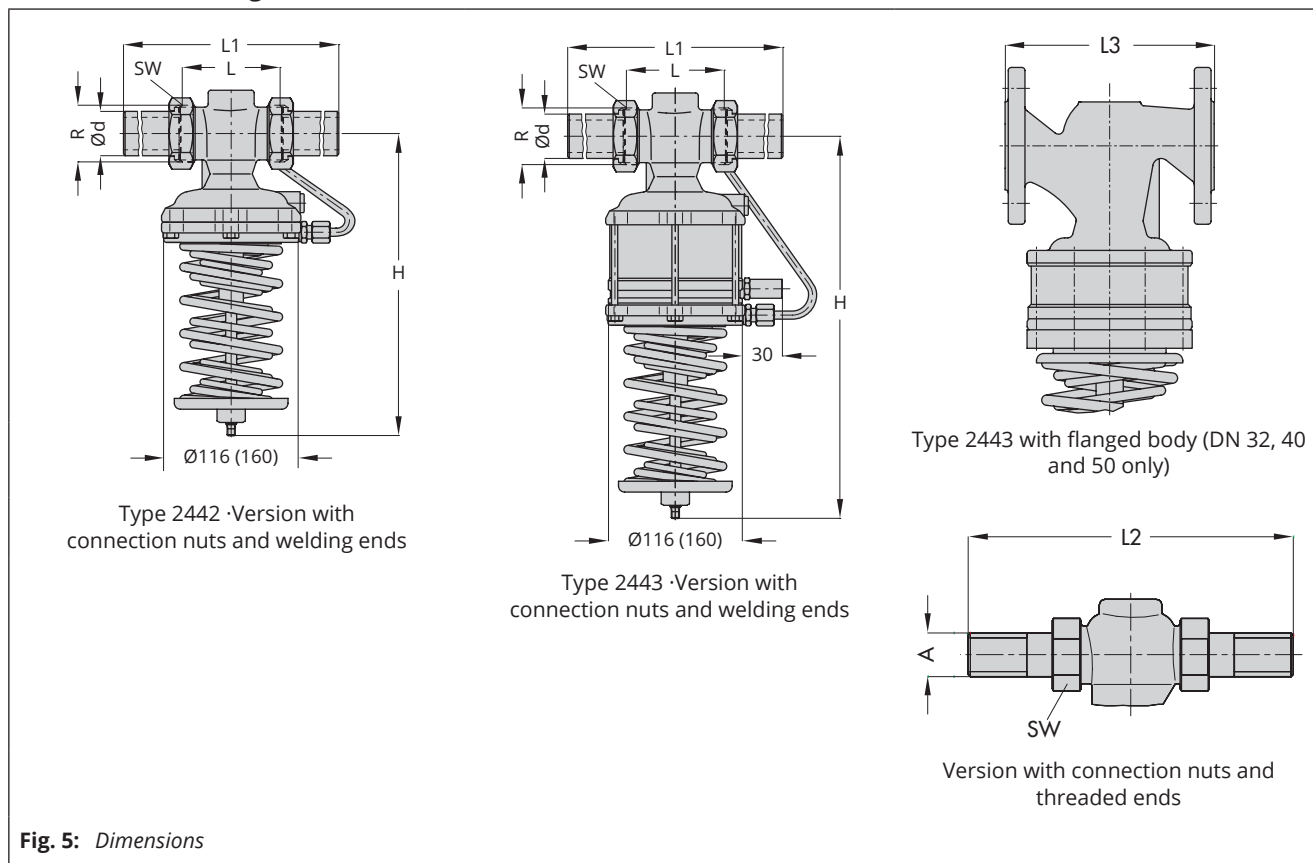

**Table 3: Dimensions in mm and weights**

| Nominal size                                | DN        | 15                      | 20                      | 25                      | 32                      | 40                        | 50                        |
|---|-----------|-------------------------|-------------------------|-------------------------|-------------------------|---------------------------|---------------------------|
| Pipe Ød                                     |           | 21.3                    | 26.8                    | 33.7                    | 42.0                    | 48.0                      | 60.0                      |
| Connection R                                |           | G ¾                     | G 1                     | G 1¼                    | G 1¾                    | G 2                       | G 2½                      |
| Width across flats (A/F)                    |           | 30                      | 37                      | 46                      | 60                      | 65                        | 82                        |
| L   |           | 65                      | 70                      | 75                      | 100                     | 110                       | 130                       |
| L1 with welding ends                        |           | 210                     | 234                     | 244                     | 268                     | 294                       | 330                       |
| H   | Type 2442 | 231 · 252 <sup>1)</sup> |                         |                         | 253 · 274 <sup>1)</sup> |                           | 382                       |
|   | Type 2443 | 286 · 306 <sup>1)</sup> |                         |                         | 310 · 330 <sup>1)</sup> |                           | 454                       |
| ØD  |           | 116                     |                         |                         |                         | 160                       |                           |
| X   | Type 2443 | 30                      |                         |                         |                         |                           |                           |
| Weight of Type 2442, approx. kg             |           | 3.1 · 3.9 <sup>2)</sup> | 3.2 · 4.0 <sup>2)</sup> | 3.5 · 4.7 <sup>2)</sup> | 5.1 · 6.3 <sup>2)</sup> | 13.2 · 13.8 <sup>2)</sup> | 14.8 · 16.4 <sup>2)</sup> |
| <b>With flanged body (DN 32, 40 and 50)</b> |           |                         |                         |                         |                         |                           |                           |
| L3  |           | -                       |                         |                         | 180                     | 200                       | 230                       |
| Weight of Type 2442, approx. kg             |           | -                       |                         |                         | 8.0 · 9.0 <sup>2)</sup> | 18.0 · 19.9 <sup>2)</sup> | 19.2 · 21.1 <sup>2)</sup> |
| <b>Special version</b>                      |           |                         |                         |                         |                         |                           |                           |
| <b>With threaded ends (male thread)</b>     |           |                         |                         |                         |                         |                           |                           |
| L2  |           | 129                     | 144                     | 159                     | 192                     | 206                       | 228                       |
| Male thread A                               |           | G ½                     | G ¾                     | G 1                     | G 1¼                    | G 1½                      | G 2                       |
| Weight of Type 2442, approx. kg             |           | 3.0 · 3.8 <sup>2)</sup> | 3.1 · 3.9 <sup>2)</sup> | 3.4 · 4.6 <sup>2)</sup> | 5.0 · 6.2 <sup>2)</sup> | 12.9 · 13.5 <sup>2)</sup> | 14.4 · 16.0 <sup>2)</sup> |

<sup>1)</sup> Set point range 6 to 10.5 bar

<sup>2)</sup> Type 2443