

T 2632 EN

Type 2444 (Type 44-4) Safety Excess Pressure Valve (SEV)

Series 44 Self-operated Pressure Regulators



Application

Pressure regulator for set points from **2 to 11 bar** · Valves in **DN 15 to 50** · **PN 25** · Suitable for liquids up to **150 °C**, air and nitrogen up to **80 °C** · Safety excess pressure valve (SEV) for protecting district heating plants
The valve **opens** when the **upstream** pressure rises.

The Type 2444 Safety Excess Pressure Valve controls the variable pressure upstream of the valve to an adjustable set point, especially in district heating plants and large heating systems. It releases the heat flow when a set point is reached. The valve opens when the upstream pressure rises and closes again when this pressure drops.

In the event of a ruptured operating diaphragm in the actuator, the valve opens (fail-open) at an upstream pressure above 0.5 bar. An indicator at the actuator shows that the actuator is damaged.

As a result, the regulators comply with AGFW (German District Heating Association) requirements for district heating plants.

Special features

- Suitable for water and other liquids, provided these do not cause the materials used to corrode.
- Single-seated valve with balanced plug
- The regulators comply with requirements of FW 506 published by AGFW (German District Heating Association).

Versions (see Fig. 2 and Fig. 3)

Type 2444 Safety Excess Pressure Valve (SEV) with two operating diaphragms · Set point ranges from 2 to 11 bar · Nominal sizes DN 15 to 50 · With welding ends (special version with threaded ends or flanges) · DN 32, 40 and 50 versions also available with flanged valve body · In the event of a ruptured operating diaphragm in the actuator, the valve opens · **Typetested according to AGFW document FW 506**

Special version

- Restricted flow cross-section with K_{VS} 1.0 or K_{VS} 4.0 for DN 15
- With internal parts made of FKM, e.g. for use with mineral oils

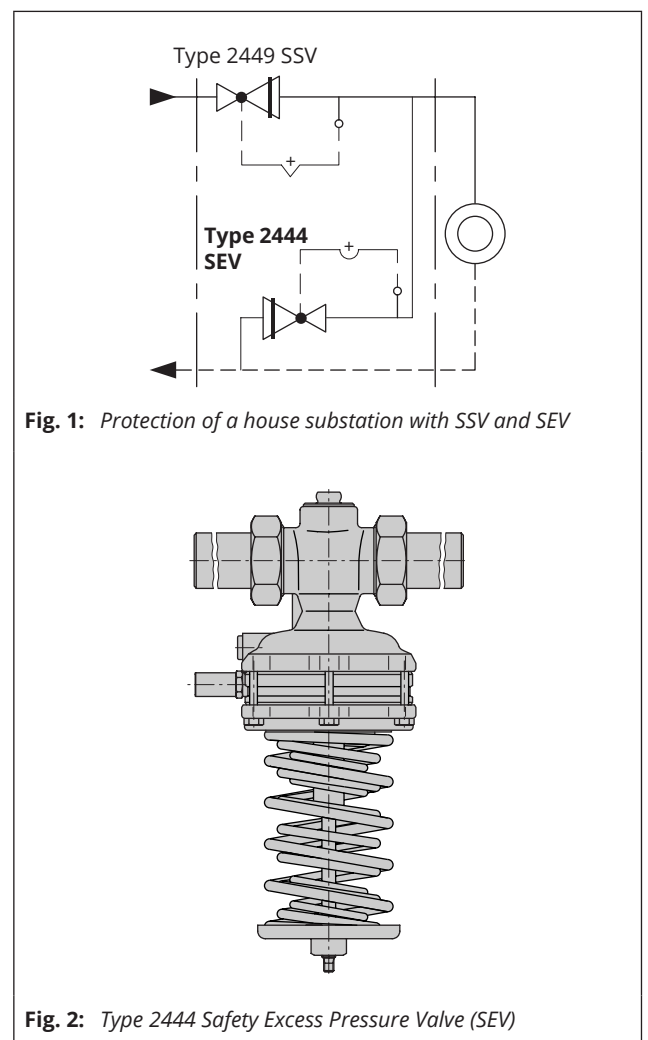

Fig. 1: Protection of a house substation with SSV and SEV

Fig. 2: Type 2444 Safety Excess Pressure Valve (SEV)

Principle of operation

The medium flows through the valve (1) as indicated by the arrow. The position of the plug determines the flow rate across the area released between plug (3) and seat (2).

The upstream pressure p_1 to be controlled is transmitted over the external control line (11) to the operating diaphragm (6.1) where it is converted into a positioning force. This force is used to move the valve plug according to the force of the spring assembly (8). The spring force can be adjusted at the set point adjuster (10).

The valve opens when the upstream pressure rises and closes again when this pressure drops.

The valve has a balanced plug (3). As a result, the forces generated by the upstream pressure which act on the valve plug are eliminated.

After the operating diaphragm (6.1) ruptures and the upstream pressure rises above 0.5 bar, the backup diaphragm (6.2) opens the plug and releases the flow.

To recognize a ruptured diaphragm, a diaphragm rupture indicator (12) is installed in the intermediate ring.

Type test

The Type 2444 Safety Excess Pressure Valve has been typetested for water by the German technical surveillance association TÜV. The test mark is available on request.

Installation

Install the regulator in horizontal pipelines.

The following points must be observed:

- The direction of flow must match the direction indicated by the arrow on the body
- Do **not** install a strainer upstream of the valve.
- The actuator must be suspended downwards.

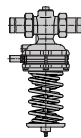

Further details can be found in ► EB 2723.

Ordering text

Type 2444 Safety Excess Pressure Valve (SEV)

DN ... with welding ends, threaded ends or flanges or with flanged body

Set point range ... bar

Special version ...

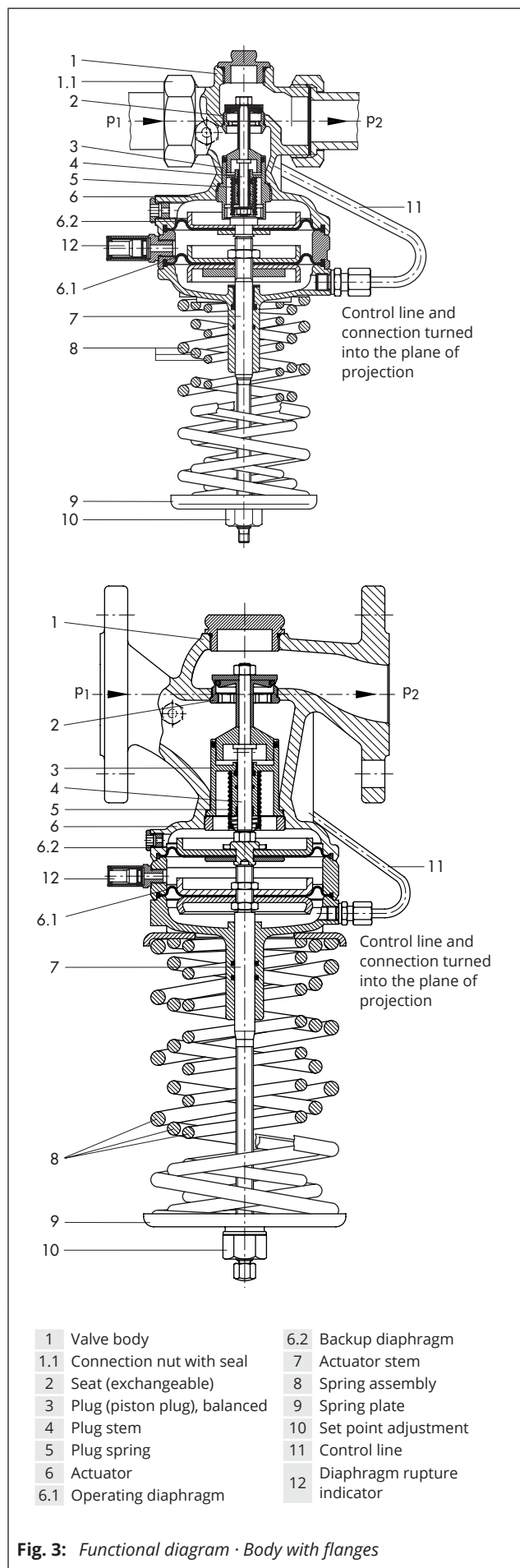

Fig. 3: Functional diagram · Body with flanges

Table 1: Technical data · All pressures in bar (gauge)

Nominal size	DN	15	20	25	32	40	50
K _{VS} coefficient	Standard version	4.0	6.3	8.0	12.5	16.0	20.0
	Special version	1.0 · 2.5			-		
	Flanged body	-			12.5	20.0	25.0
x _{FZ} value		0.6		0.55		0.5	0.45
Pressure rating		PN 25					
Max. perm. differential pressure Δp		11 bar					
Max. permissible temperature		150 °C · 80 °C ¹⁾					
Leakage class according to IEC 60534-4		≤0.05 % of K _{VS} coefficient					
Set point ranges ²⁾ , continuously adjustable		2 to 4.4 bar · 2.4 to 6.6 bar · 6 to 11 bar					
Conformity		CE					

¹⁾ With air and nitrogen

²⁾ Special set point ranges, without type test, on request

Table 2: Materials · Material numbers according to DIN EN

Type 2444 Excess Pressure Valve (SEV)	
Valve body	Red brass CC499K · Spheroidal graphite iron EN-GJS-400-18-LT ¹⁾
Actuator housing/intermediate ring	Red brass CC499K
Seat	Stainless steel 1.4305
Plug	Brass CW602N and stainless steel 1.4305 with EPDM soft seal ²⁾
Valve spring	Stainless steel 1.4310
Operating diaphragm	EPDM with fabric reinforcement ²⁾
Seals	EPDM ²⁾

¹⁾ Additional version for DN 32, 40 and 50: valve with flanged body made of spheroidal graphite iron

²⁾ Special version, e.g. for mineral oils: FKM

Flow rate diagram for water

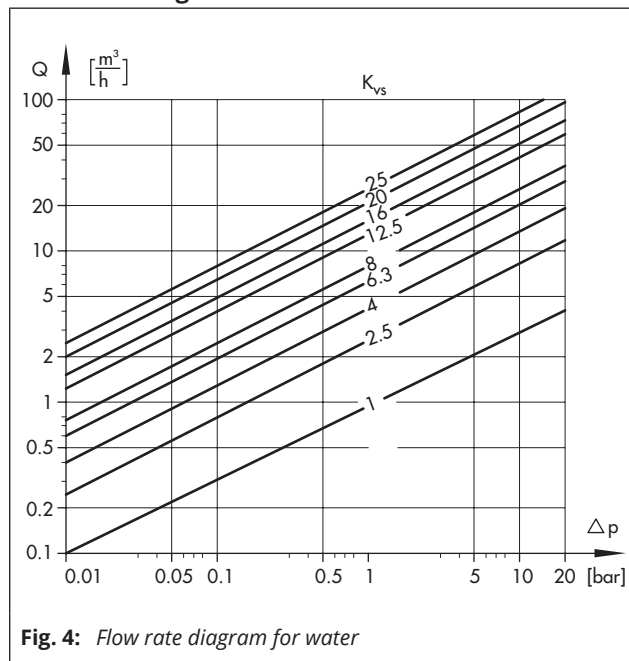

Fig. 4: Flow rate diagram for water

Dimensional drawings

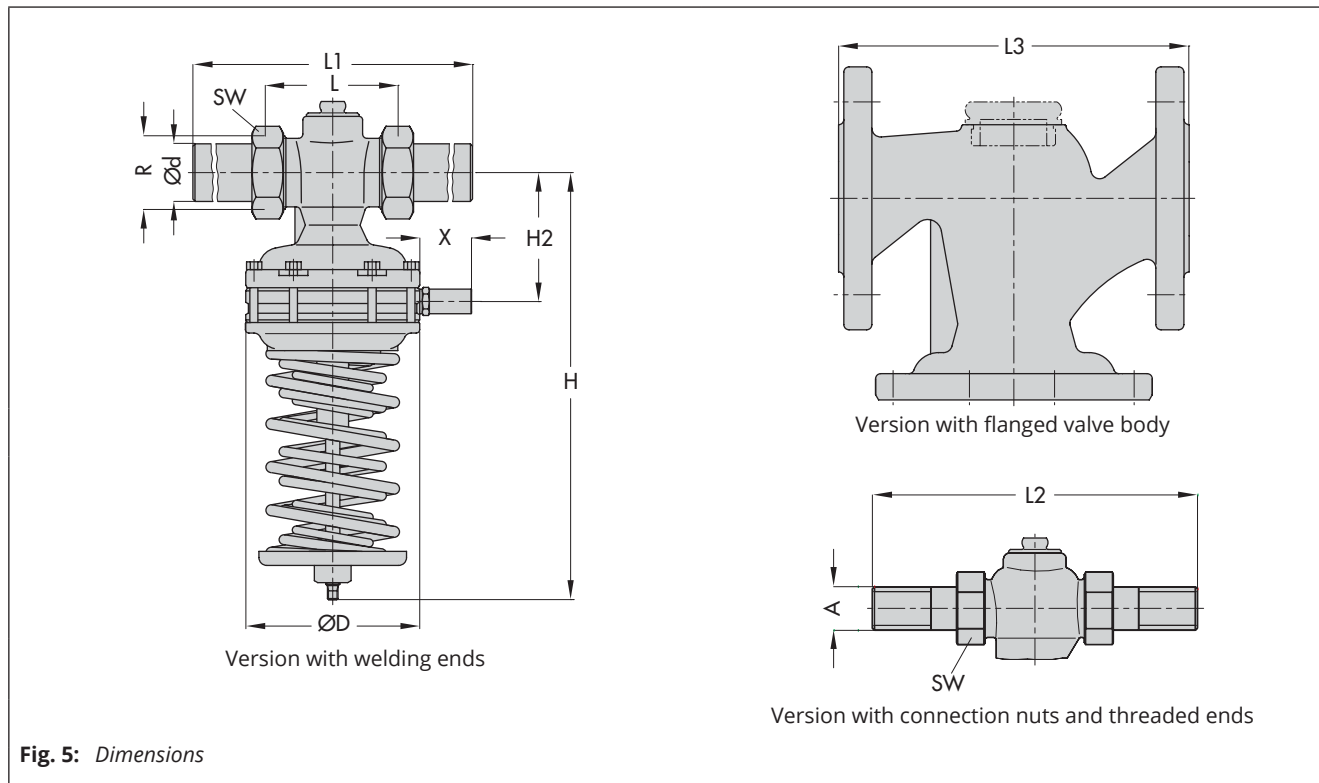

Fig. 5: Dimensions

Table 3: Dimensions in mm and weights

Nominal size	DN	15	20	25	32	40	50
Pipe Ød		21.3	26.8	33.7	42.0	48.0	60.0
Connection R		G ¾	G 1	G 1¼	G 1¾	G 2	G 2½
Width across flats (A/F)		30	37	46	60	65	82
L		65	70	75	100	110	130
L1 with welding ends		210	234	244	268	294	330
H		248 ¹⁾			272 ¹⁾	410	
H2		32			45		
ØD		116			160		
X		30					
Weight, approx. kg		3.6	3.7	4.1	5.7	11.8	14.2
Special versions							
With threaded ends (male thread)							
L2		129	144	159	192	206	228
Male thread A		G ½	G ¾	G 1	G 1¼	G 1½	G 2
Weight, approx. kg		3.5	3.6	4.0	5.5	11.5	13.8
With screwed-on flanges²⁾ or with flanged body (DN 32 to 50)							
L3		130	150	160	180	200	230
Weight, approx. kg	With screw-on flanges	4.9	5.4	6.2	8.6	15.2	18.5
	With flanged body	-	-	-	8.7	15.8	17.6

¹⁾ Set point range 6 to 11 bar: H + +19 mm

²⁾ Flanges are already mounted on valves in DN 40 and 50