

Series 280

Type 3286-1 and Type 3286-7 Pneumatic Steam Conditioning Valves

Type 3286 Steam Conditioning Valve

ANSI version

Application

Final control element (angle valve) for process engineering applications and thermal plants

Valve size	NPS 2 to 12
Pressure rating	Class 150 to 900
Temperatures	Up to 932 °F (500 °C)



Steam converters reduce the pressure and the temperature to the set points adjusted at the pressure controller and the temperature controller (Fig. 2). They consist of a Type 3286 Steam Conditioning Valve together with a Type 3271 Pneumatic Actuator (Type 3286-1 Steam Conditioning Valve) or with a Type 3277 Pneumatic Actuator (Type 3286-7 Steam Conditioning Valve).

The steam conditioning valve largely corresponds to a Type 3256 Angle Valve (► T 8066) fitted with a flow divider ST 3.

Valve body made of

- Cast steel
- High-temperature cast steel

Low-noise valve plug

- Metal seal
- High-performance metal seal
- Balanced to handle high differential pressures

Water supplied through the flow divider ST 3 ensures:

- Full utilization of the steam's kinetic energy to mix and split up the cooling water
- Fast evaporation independent of the steam flow rate
- Homogenous condition of the throttled and superheated steam
- Prevention of thermal shock or erosion caused by the cooling water entering the valve as the water does not have any contact with the valve body
- Low-vibration and low-noise operation

The steam conditioning valves with their modular design can be equipped with various accessories:

Positioners, limit switches, solenoid valves and other accessories according to IEC 60534 and NAMUR recommendation (see Information Sheet ► T 8350).

Versions

Standard version with PTFE packing for temperatures up to 428 °F (220 °C) or with adjustable high-temperature packing up to 662 °F (350 °C), valve size NPS 2 to 12, pressure rating Class 150 to 900



Fig. 1: Type 3286-1 Pneumatic Steam Conditioning Valve

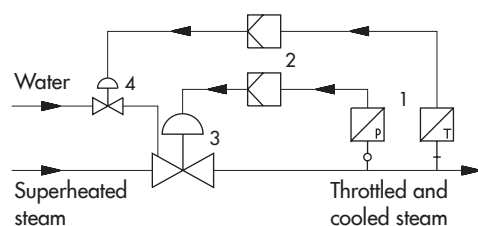

- | | |
|---------------|-----------------------------------|
| 1 Transmitter | 3 Steam conditioner |
| 2 Controller | 4 Control valve for cooling water |

Fig. 2: Steam pressure/temperature control with steam conditioner

- **Type 3286-1** (Fig. 1) · Type 3286 Steam Conditioning Valve and Type 3271 Actuator with 350 to 2800 cm² actuator area (see Data Sheets ► T 8310-1, ► T 8310-2 and ► T 8310-3)
- **Type 3286-7** · Type 3286 Steam Conditioning Valve and Type 3277 Actuator with 350 to 750v2 cm² actuator area (see Data Sheet ► T 8310-1)

Further versions

- **Welding ends** according to ASME B16.25
- **Insulating section** for temperatures up to 932 °F (500 °C)
- **Additional handwheel** · See Data Sheets ▶ T 8310-1, ▶ T 8310-2 and ▶ T 8310-3
- **DIN version** · DN 50 to 300, PN 16 to 160 · See Data Sheet ▶ T 8256
- **Perforated plug**

Principle of operation

The seat (4), plug with plug stem (5) and flow divider (62) are installed in the body (1). The plug stem is connected to the actuator stem (A7) by the stem connector clamps (A26/27) and is sealed by a spring-loaded V-ring packing (15). Alternatively, an adjustable high-temperature packing can be used.

The medium flows through the valve in the direction indicated by the arrow. The plug position determines the cross-sectional area between the seat and plug.

The cooling water is fed to the flow divider (62) through the connecting pipe on the bonnet (2) and holes in the clamping element (63). After flowing through the cross-sectional area between seat and plug, the steam flow reaches its maximum velocity and comes into contact with the cooling water at the inner wall of the flow divider. The steam flow and the entrained water are mixed in the narrow wire mesh of the flow divider. At the same time, the steam velocity is reduced, releasing some of its heat to the water across the large surface of the wire mesh coil, which causes it to evaporate quickly. The steam/water mixture leaves the flow divider as a fine mist with a high steam content. Evaporation is completed a short distance downstream of the steam conditioning valve. The water atomization described is ensured over the whole load range since the steam velocity at the throttling point is independent of the flow rate.

Fail-safe position

Depending on how the springs are arranged in the pneumatic actuator, the valve has two different fail-safe positions that become effective when the supply air fails or when the air supply pressure drops.

- **Actuator stem extends (fail-close):** the valve closes when the supply air fails.
- **Actuator stem retracts (fail-open):** the valve opens when the supply air fails.

Differential pressures

The permissible differential pressures can be found in the Information Sheet ▶ T 8000-4.

Note: Fig. 3 to Fig. 4 show configuration examples.

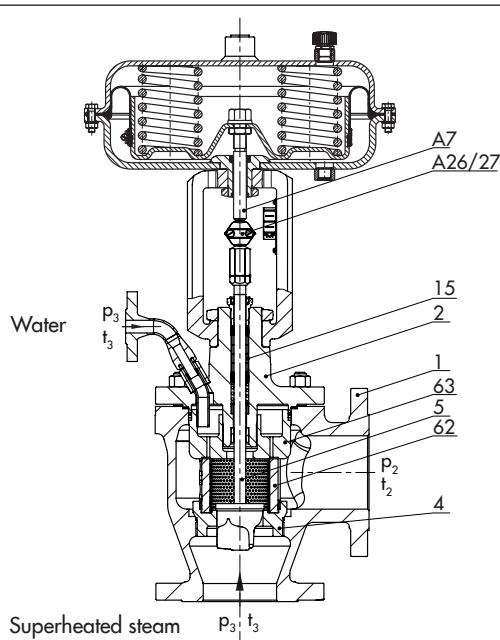

Fig. 3: Type 3286 Steam Conditioning Valve with Type 3271 Pneumatic Actuator

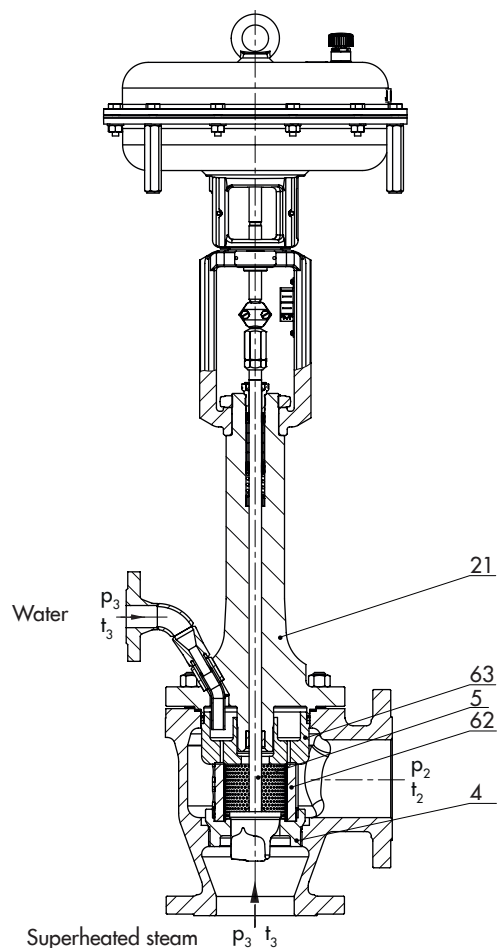

Fig. 4: Type 3286 Steam Conditioning Valve with insulating section and Type 3277 Pneumatic Actuator

Legend for Fig. 3 and Fig. 4

1 Body	5 Plug with plug stem	
2 Bonnet with connecting pipe	15 Packing	63 Clamping element
4 Seat	21 Insulating section	A7 Actuator stem
	62 Flow divider ST 3	A26/27 Stem connector clamps

Table 1: Technical data of Type 3286 Steam Conditioning Valve

Material		Cast steel · A216 WCC	Cast steel · A217 WC6
Valve size	NPS	2 to 12	
Pressure rating	Class	150 to 900	
Type of connection	Flanges	ASME B16.5	
	Welding ends	ASME B16.25	
Seat-plug seal		Metal seal or high-performance metal seal	
Characteristic		Equal percentage or linear	
Rangeability		50:1	
Compliance		CE · EAC	
Temperature ranges · Permissible operating pressures acc. to pressure-temperature diagrams (see Information Sheet ► T 8000-2)			
Body without insulating section		14 to 428 °F (-10 to +220 °C) Up to 660 °F (up to 350 °C) with high-temperature packing	
Body with	Insulating section	-20 to +800 °F (-29 to +427 °C)	-20 to +932 °F (-29 to +500 °C)
Valve plug	Standard Metal seal	-20 to +932 °F (-29 to 500 °C)	
	Balanced with PTFE	-20 to +428 °F (-29 to +220 °C)	
	Balanced with graphite ring	-20 to +932 °F (-29 to +500 °C)	
Leakage class according to ANSI/FCI 70-2			
Valve plug	Standard Metal seal	IV	
	Standard High-performance metal seal	V	
	Balanced with PTFE	Standard: IV · High-performance metal seal: V	
	Balanced with graphite ring	IV	

Table 2: Materials

Standard version with body and flanges ¹⁾		Cast steel · A216 WCC	Cast steel · A217 WC6
Seat and plug ²⁾	Metal seal	410-2/1.4008	
	Seal ring for balanced plug	PTFE/graphite	
Guide bushings		1.4112	
Packing		V-ring packing: PTFE with carbon, spring: 302 or high-temperature packing	
Body gasket		Graphite seal on metal core	
Insulating section		A216 WCC/A105	A217 WC6/A182 F12 Cl.2

¹⁾ See also pressure-temperature diagrams (► T 8000-2)

²⁾ Seats and metal-seated plug also with Stellite® facing or plug made of solid Stellite® available

Table 3: Available C_V and K_{VS} coefficients · Versions highlighted in gray also available with balanced plug

C_V		3.5	5.6	9	14	23	35	55	90	140	220	315	560	880
K_{VS}		3.0	4.8	7.5	12	20	30	47	75	120	190	270	480	750
Seat Ø	in	0.94			1.22	1.50	1.97	2.48	3.15	3.94	4.92	5.91	7.87	9.84
	mm	24			31	38	50	63	80	100	125	150	200	250
Travel	in	0.59					1.18					2.36		4.72
	mm	15					30					60		120
NPS	DN													
2 ¹⁾	50 ¹⁾	•	•	•										
3	80	•	•	•	•	•	•							
4	100					•	•	•						
6	150							•	•	•				
8	200								•	•	• ¹⁾	•		
10	250								•	•	• ¹⁾	•	•	
12	300									•	• ¹⁾	•	•	•

¹⁾ Version with balanced plug: seat bore 125 is only possible for Class 600 and 900. A special lathed plug and seat bore 150 (special version) are required for Class 150 and 300.

Selection and sizing of the steam conditioning valve

The steam conditioning valves require particularly careful sizing. Therefore, SAMSON performs the final sizing of the valves.

1. Calculate the suitable C_v coefficient according to IEC 60534.
2. Select valve size and C_v coefficient from Table 3.
3. Select materials, pressure and temperature from Table 1 and Table 2 and from the pressure-temperature diagram (► T 8000-2).
4. Select accessories from Table 1 and Table 2.
5. Check the installation conditions as described in TV-SK 9778-1.
6. Check the limits of application (more details on request).

Table 4: Dimensions for standard versions of Type 3286-1 and Type 3286-7 Pneumatic Steam Conditioning Valves

Table 4.1: Type 3286 Steam Conditioning Valve · Face-to-face dimensions according to ANSI/ISA-75.08.01 for Class 600 and lower and according to ASME B16.10 for Class 900 and higher

Valve	NPS	DN	2	3	4	6	8	10	12	
			50	80	100	150	200	250	300	
Length L2	Class 150	in	5.00	5.88	6.94	8.88	10.69	On request		
		mm	127	149	176	226	272			
	Class 300	in	5.25	6.25	7.25	9.31	11.19			
		mm	133	159	184	236	284			
	Class 600	in	5.62	6.62	7.75	10.00	12.00			
		mm	143	168	197	254	305			
Class 900	in	7.25	7.50	9.00	12.00	14.50				
	mm	184	190	229	305	368				
Height H4	Class 150 to 600	in	6.89	6.30	6.69	9.13	On request			
		mm	175	160	170	210				
	Class 900	in	8.70	6.30	6.69	9.13				
		mm	221	160	170	210				
H8 for actuator	350 cm ²	in	9.45	9.45	9.45	-				
		mm	240	240	240					
	355v2 cm ²	in	9.45	9.45	9.45	16.46	-			
		mm	240	240	240	418				
	700 cm ²	in	9.45	9.45	9.45	16.46	16.46	-		
		mm	240	240	240	418	418			
	750v2 cm ²	in	9.45	9.45	9.45	16.46	16.46	16.46	-	
		mm	240	240	240	418	418	418		
	1000 cm ²	in	11.61	11.61	11.61	16.46	16.46	-		
		mm	295	295	295	418	418			
	1400-60 cm ²	in	11.61	11.61	11.61	16.46	16.46	19.81	19.81	
		mm	295	295	295	418	418	503	503	
	1400-120 cm ²	in	18.90	18.90	18.90	19.81	19.81	19.81	19.81	
		mm	480	480	480	503	503	503	503	
	2800 cm ²	in	18.90	18.90	18.90	19.81	19.81	25.60	25.60	
		mm	480	480	480	503	503	650	650	
2 x 2800 cm ²	in	18.90	18.90	18.90	19.81	19.81	19.81 ¹⁾	25.60		
	mm	480	480	480	503	503	503 ¹⁾	650		

¹⁾ H8 = 25.60" (650 mm) with 9.84" (250 mm) seat bore

Table 4.2: Types 3271 and 3277 Pneumatic Actuators

Actuator area	cm ²	350	355v2	700	750v2	1000	1400-60	1400-120	2800	2 x 2800
Diaphragm ØD	in	11.02	11.02	15.35	15.51	18.19	20.87	21.02	30.32	30.32
	mm	280	280	390	394	462	530	534	770	770
H ¹⁾	in	3.23	4.76	7.83	9.29	15.87	13.27	23.54	28.07	47.76
	mm	82	121	199	236	403	337	598	713	1213
H3 ²⁾	in	4.33	4.33	7.48	7.48	24.02	24.02	25.59	25.59	25.59
	mm	110	110	190	190	610	610	650	650	650
H5	Type 3277 in	3.98	3.98	3.98	3.98	-	-	-	-	-
	Type 3277 mm	101	101	101	101	-	-	-	-	-
Thread	Type 3271	M30x1.5				M60x1.5		M100x2		
	Type 3277	M30x1.5				-	-	-	-	-
α	Type 3271	G 3/8 (3/8 NPT)	G 3/8 (3/8 NPT)	G 3/8 (3/8 NPT)	G 3/8 (3/8 NPT)	G 3/4 (3/4 NPT)	G 3/4 (3/4 NPT)	G 1 (1 NPT)	G 1 (1 NPT)	G 1 (1 NPT)
α2	Type 3277	G 3/8	G 3/8	G 3/8	G 3/8	-	-	-	-	-

- 1) Height including lifting eyelet or female thread and eyebolt according to DIN 580. Height of the swivel lifting hook may differ. Actuators up to 355v2 cm² without lifting eyelet or female thread
 2) Minimum clearance required to remove the actuator

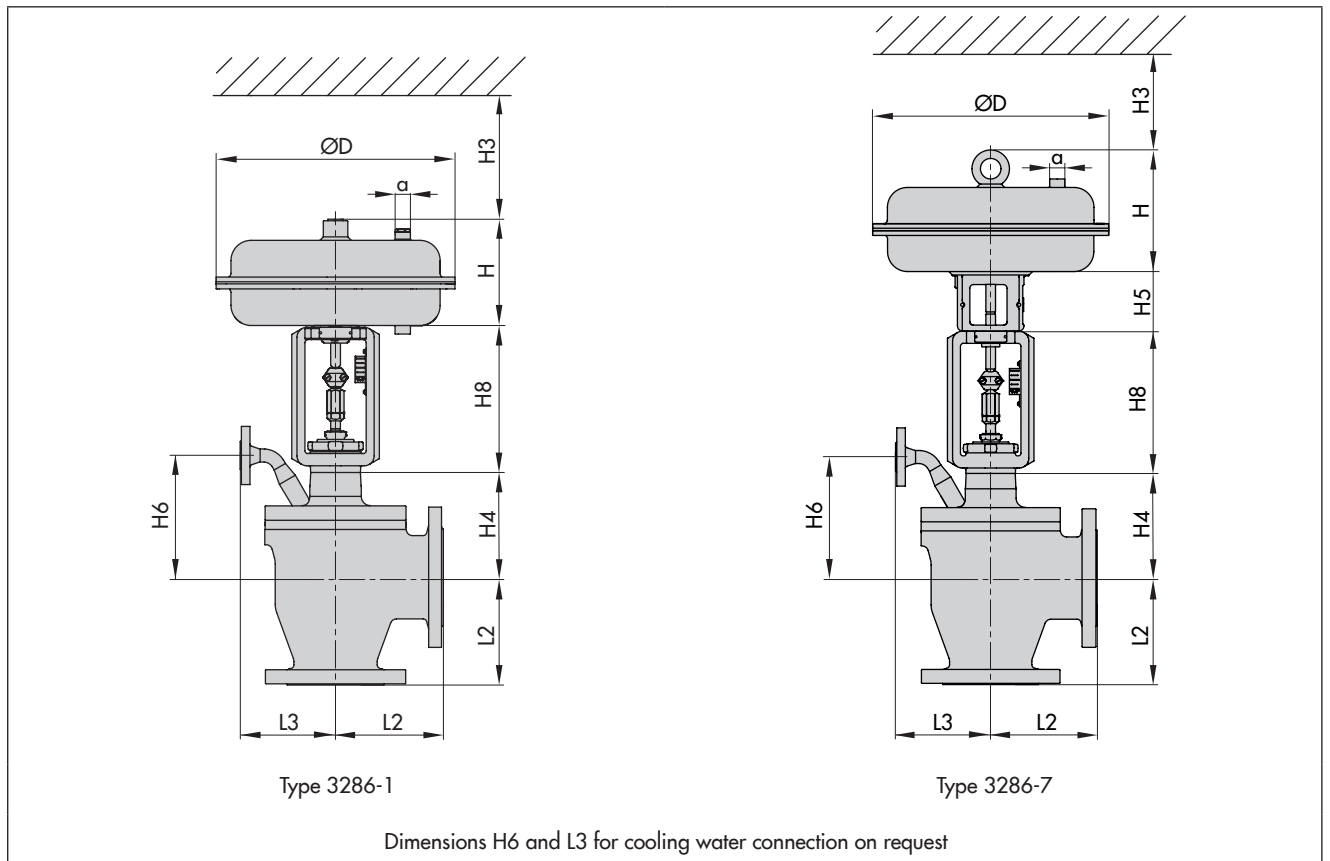

Table 5: *Weights (approx.) for standard version of Type 3286-1 and Type 3286-7 Pneumatic Steam Conditioning Valves*

Table 5.1: *Type 3286 Steam Conditioning Valve*

Valve		NPS	2	3	4	6	8	10	12
		DN	50	80	100	150	200	250	300
Valve without actuator	Class 150	lbs	66	110	152	342	948	1892	2028
		kg	30	50	69	155	460	858	920
	Class 300	lbs	95	170	247	694	948	1892	2028
		kg	43	77	112	315	430	858	920
	Class 600	lbs	95	170	247	694	1096	2509	2535
		kg	43	77	112	315	497	1138	1150
	Class 900	lbs	95	170	247	694	1157	2844	3263
		kg	43	77	112	315	525	1290	1480

Table 5.2: *Types 3271 and 3277 Pneumatic Actuators*

Actuator	cm ²	350	355v2	700	750v2	1000	1400-60	1400-120	2800	2 x 2800
Type 3271 without handwheel	lbs	18	33	49	80	187	154	386	992	2094
	kg	8	15	22	36	85	70	175	450	950
Type 3271 with handwheel	lbs	29	44	60	91	419	386	661 ¹⁾ / 937 ²⁾	1268 ¹⁾ / 1543 ²⁾	On request
	kg	13	20	27	41	190	175	300 ¹⁾ / 425 ²⁾	575 ¹⁾ / 700 ²⁾	
Type 3277 without handwheel	lbs	26	42	57	88	-				
	kg	12	19	26	40					
Type 3277 with handwheel	lbs	37	53	68	100					
	kg	17	24	31	45					

¹⁾ Handwheel up to 80 mm travel

²⁾ Side-mounted handwheel above 80 mm travel

Table 6: Dimensions for the standard version of the Type 3286 Steam Conditioning Valve with insulating section

Valve	NPS		2	3	4	6	8	10	12
	DN		50	80	100	150	200	250	300
Height H4	Class 150 to 600	in	17.52	16.93	17.32	22.05	On request		
		mm	445	430	440	560			
	Class 900	in	19.13	16.93	17.32	22.05			
		mm	586	430	440	560			

Table 7: Weights (approx.) for the standard version of the Type 3286 Steam Conditioning Valve with insulating section

Valve	NPS		2	3	4	6	8	10	12
	DN		50	80	100	150	200	250	300
Valve without actuator	Class 150 to 300	lbs	111	172	232	552	1048	On request	
		kg	50	78	105	250	475		
	Class 600 to 900	lbs	166	254	353	838	1510		
		kg	75	115	160	380	685		

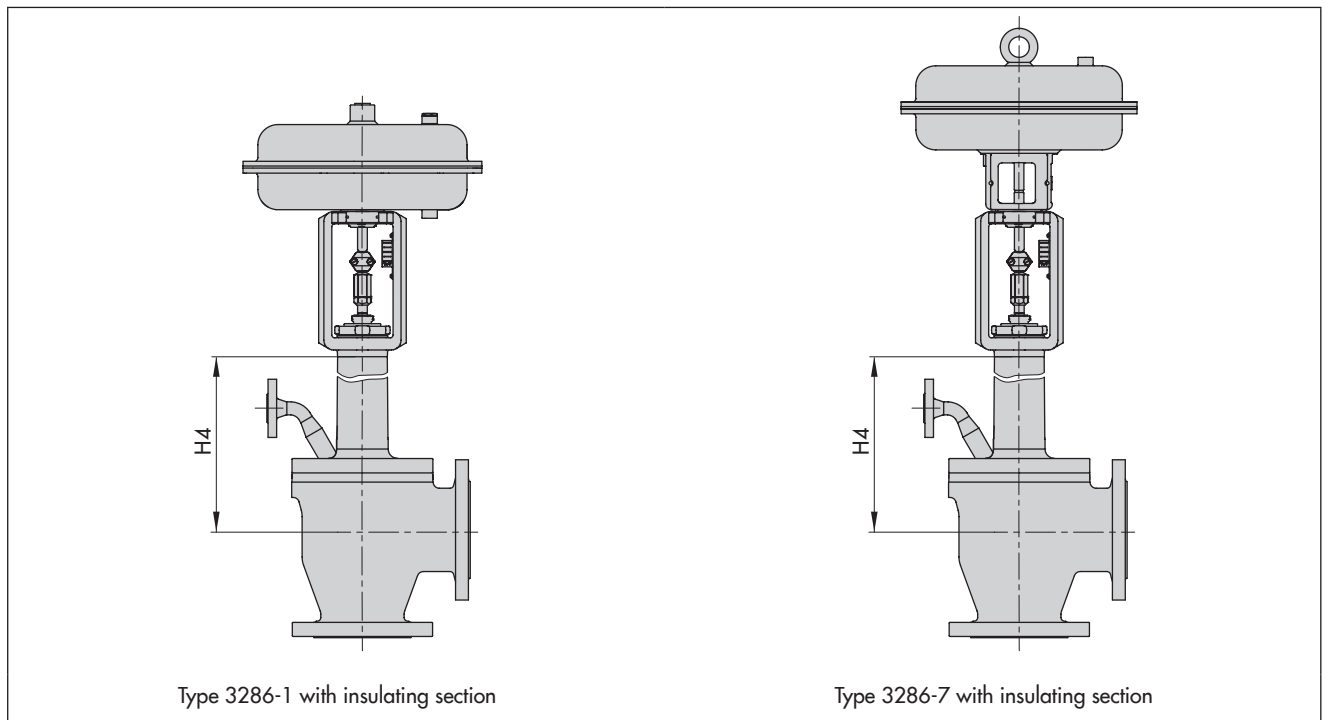

The following specifications are required on ordering:

Steam conditioner	Type 3286 Angle Valve
Valve size	NPS ...
Pressure rating	ANSI Class ...
Body material	According to Table 2
Type of connection	Flanges or welding ends
Plug	Standard or balanced
Characteristic	Equal percentage or linear
Max. and min. flow rate of the superheated steam or cooled steam	in lbs/h or kg/h
Steam pressure upstream and downstream of the valve	p_1 and p_2
Steam temperature upstream and downstream of the valve	T_1 and T_2
Cooling water pressure and temperature upstream of the valve	p_3 and T_3
Actuator	Type 3271 or Type 3277
Actuator area	... cm ²
Fail-safe action	Fail-close or fail-open
Valve accessories	Positioner and/or limit switch

Specifications subject to change without notice



SAMSON AG · MESS- UND REGELTECHNIK
Weismüllerstraße 3 · 60314 Frankfurt am Main, Germany
Phone: +49 69 4009-0 · Fax: +49 69 4009-1507
samson@samson.de · www.samson.de

T 8257 EN

2018-05-03 · English