

# DATA SHEET

## T 8355 EN

### Type 3766 Pneumatic Positioner Type 3767 Electropneumatic Positioner



#### Application

Single-acting or double-acting positioners for attachment to pneumatic control valves. These positioners use a pneumatic input signal from 0.2 to 1 bar or 3 to 15 psi (Type 3766) or an electric input signal from 0/4 to 20 mA or 1 to 5 mA (Type 3767).

**Rated travels from 7.5 to 120 mm or opening angles up to 90°**

The positioners ensure a predetermined assignment of the valve position (controlled variable  $x$ ) to the input signal (reference variable  $w$ ). They compare the input signal received from a control system to the travel of the control valve and issue a corresponding output signal pressure  $p_{st}$  (output variable  $y$ ). A reversing amplifier for double-acting actuators produces two opposed signal pressures.

#### Special features

- Any mounting position possible, suitable for normal or split-range operation, excellent dynamic response, negligibly small influence of supply air, adjustable proportional band (P band), adjustable air output capacity, low air supply consumption, very insensitive to mechanical vibrations, low-maintenance compact design.
- Versions for use in hazardous areas in type of protection intrinsic safety II 2G Ex ia IIC T6 or II 3G Ex nA II T6 for Zone 2
- Type of protection "Flameproof enclosure" Ex d with Type 3766 Positioner and Type 6116 i/p Converter (Fig. 2)
- Direct attachment to Type 3277 Actuator (Fig. 3)
- Attachment to actuators according to IEC 60534-6
- Attachment to rotary actuators according to VDI/VDE 3845

#### Benefits of direct positioner attachment (Fig. 3)

- Tight and exact mechanical connection between actuator and positioner. No misalignment during shipping.
- Travel pick-off protected against touching and external influences, meeting the requirements of the German Accident Prevention Regulations (VBG 5)
- Simple pneumatic connection between actuator and positioner
- Ready-adjusted unit: actuator with positioner

Optionally with pressure gauge for monitoring the supply air and signal pressure (dial range from 0 to 6 bar and 0 to 90 psi).

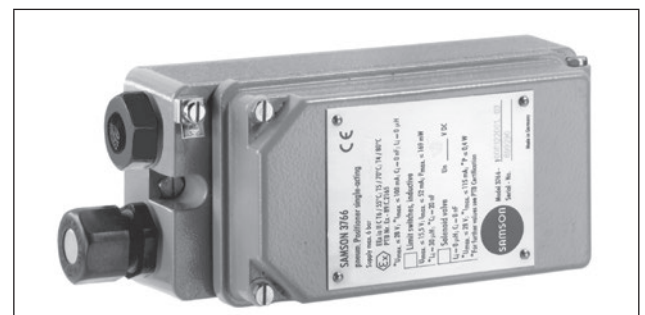

Fig. 1: Type 3766/Type 3767 Positioner



Fig. 2: Type 3766 Ex d Positioner with Type 6116 i/p Converter



Fig. 3: Direct attachment to Type 3241-7 Control Valve

For more information on the selection and application of positioners, converters, limit switches, and solenoid valves, refer to Information Sheet ► T 8350.

### Versions

- **Type 3766** · Pneumatic positioner
- **Type 3767** · Electropneumatic positioner

Refer to article code for details on possible configurations.

### Principle of operation (Fig. 4)

The positioners are used to assign the valve position (controlled variable  $x$ ) to the input signal (reference variable  $w$ ). The positioners compare the control signal of a control system to the travel of the control valve and issues a signal pressure (output variable) for the pneumatic actuator.

Both positioners function according to the force-balance principle. The only difference between the two positioners is an i/p converter unit in the Type 3767 Electropneumatic Positioner.

### Type 3766 · Pneumatic positioner

The positioner consists of a lever for travel pick-up, a measuring diaphragm, and the pneumatic control system with nozzle, diaphragm lever (flapper plate), and booster.

The valve travel, i.e. the valve position, is transmitted to the pick-up lever (1) over the pin (1.1) and determines the force of the range spring (4). This force is compared to the positioning force generated by the pressure  $p_e$  at the measuring diaphragm (5).

If either the control signal or the valve position changes, the diaphragm lever (3) moves, altering the distance to the nozzle (2.1 or 2.2), depending on the adjusted direction of action of the positioner.

The supply air is supplied to the booster (10) and the pressure regulator (9). The controlled supply air flows through the  $X_p$  restriction (8) and the nozzle (2.1, 2.2) and hits the diaphragm lever (flapper plate).

### Type 3767 · Electropneumatic positioner

The positioner consists of an electropneumatic converter and a pneumatic unit equipped with a lever for travel pick-up, a measuring diaphragm, and the pneumatic control system with nozzle, diaphragm lever (flapper plate), and booster.

The control signal, e.g. 4 to 20 mA, issued by the controller is transmitted to the electropneumatic converter (13) where it is converted into a proportional pressure signal  $p_e$ .

The valve travel, i.e. the valve position, is transmitted to the pick-up lever (1) over the pin (1.1) and determines the force of the range spring (4). This force is compared to the positioning force generated by the pressure  $p_e$  at the measuring diaphragm (5).

If either the control signal or the valve position changes, the diaphragm lever (3) moves, altering the distance to the nozzle (2.1 or 2.2), depending on the adjusted direction of action of the positioner.

The supply air is supplied to the booster (10) and the pressure regulator (9).

The controlled supply air flows through the  $X_p$  restriction (8) and the nozzle (2.1, 2.2) and hits the diaphragm lever (flapper plate).

### Type 3766 and Type 3767

Any change in the reference variable or the valve position causes the pressure to change upstream or downstream of the booster.

The air controlled by the booster (signal pressure  $p_{st}$ ) flows through the volume restriction (11) to the pneumatic actuator, causing the plug stem to move to a position corresponding to the reference variable.

The adjustable  $X_p$  restriction (8) and volume restriction (11) are used to optimize the positioner control loop.

The pick-up lever (1) and the range spring (4) must be selected to match the rated valve travel and the nominal span of the reference variable.

The positioner can be additionally equipped with either inductive limit contacts and/or a solenoid valve or position transmitter.

### Additional equipment

#### Positioner with inductive limit contacts

In this version, the rotary shaft of the positioner carries two adjustable tags which actuate the built-in proximity switches.

#### Positioner with solenoid valve

When the positioner is equipped with a solenoid valve, the valve can be moved to the fail-safe position, regardless of the positioner's output signal. If a control signal corresponding to the binary signal '0' (OFF) is applied to the input, the signal pressure  $p_{st}$  is shut off and the actuator is vented. The actuator springs move the valve to its fail-safe position.

When a control signal corresponding to the binary signal '1' (ON) is applied to the input, the signal pressure  $p_{st}$  is applied to the actuator, allowing the valve to move according to the input signal issued by the control equipment.

#### Positioner with position transmitter

A positioner containing a position transmitter cannot be equipped with integrated inductive limit contacts or a solenoid valve since the position transmitter requires most of the space inside.

The position transmitter is used to assign the valve position, i.e. the valve travel, to an output signal of 4 to 20 mA.

The tuning of the position transmitter ensures that both end positions "valve CLOSED" and "valve OPEN" as well as all intermediate positions can be signaled. Since the valve position is signaled independently of the input signal to the positioner, the position transmitter is a suitable option for checking the actual valve position.

**Functional diagram of Type 3766 Pneumatic Positioner**

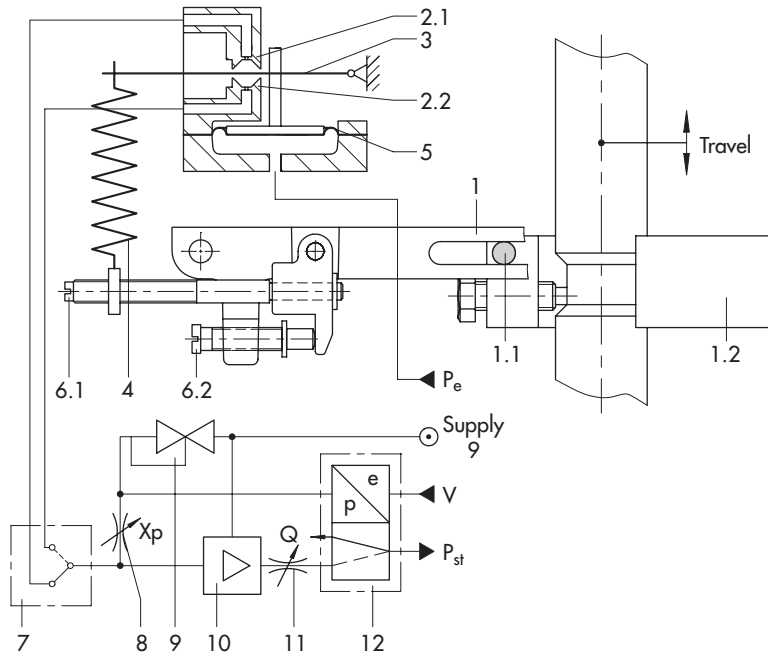

**Functional diagram of Type 3767 Electropneumatic Positioner**

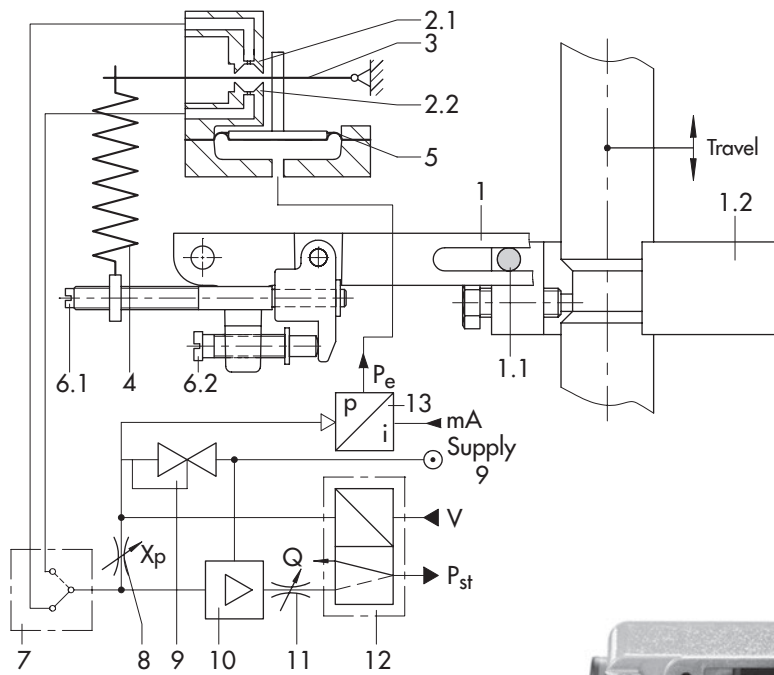

- 1 Lever
- 1.1 Pin
- 1.2 Clamp
- 2.1 Nozzle >>
- 2.2 Nozzle <<
- 3 Diaphragm lever
- 4 Range spring
- 5 Measuring diaphragm
- 6.1 Span adjuster
- 6.2 Zero adjuster
- 7 Turnboard
- 8 Xp restriction
- 9 Pressure regulator
- 10 Booster
- 11 Volume restriction
- 12 Solenoid valve (option)
- 13 i/p converter

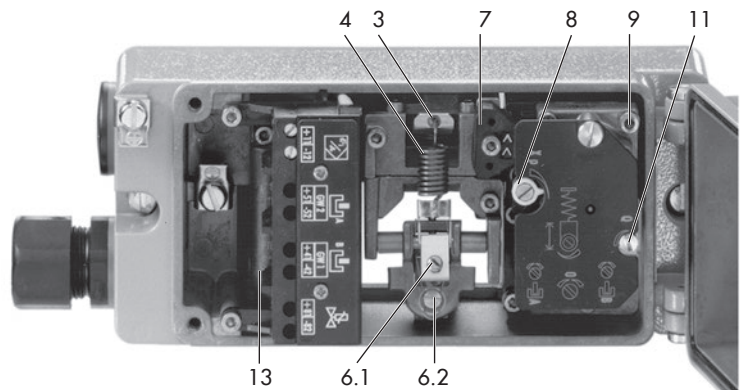

**Fig. 4:** Design and principle of operation

**Table 1: Technical data**

Type 3766 and Type 3767 Positioners			
Travel range		Direct attachment to Type 3277 Actuator: 7.5 to 30 mm	
		Attachment acc. to IEC 60534 (NAMUR): 7.5 to 120 mm	
Opening angles		70°, 75° or 90° depending on the cam disk	
Reference variable w (Type 3766)	Signal range	0.2 to 1 bar (3 to 15 psi)	
	Span	0.4 to 0.8 bar (6 to 12 psi)	
	Overloadable up to max.	2 bar (29 psi)	
Reference variable w (Type 3767)	Two-wire device, reverse polarity protection		
	Signal range	0/4 to 20 mA	1 to 5 mA
	Span	8 to 20 mA	2 to 4 mA
	Coil resistance R <sub>i</sub> at 20 °C	200 Ω	880 Ω
Supply air	Supply air	1.4 to 6 bar (20 to 90 psi)	
	Air quality acc. to ISO 8573-1 (edition 2001-02)	Maximum particle size and density: Class 4 · Oil content: Class 3 Pressure dew point: Class 3 or at least 10 K below the lowest ambient temperature to be expected.	
Signal pressure p <sub>s</sub> (output)		Can be limited between 0 to approx. 2.5 bar and 0 to 6 bar (0 to approx. 35 psi and 0 to 90 psi)	
Characteristic		Linear characteristic · Deviation from characteristic according to terminal point method: ≤ 1 %	
Hysteresis		≤ 0.6 %	
Sensitivity		≤ 0.1 %	
Direction of action		Reversible	
Proportional band X <sub>p</sub>		0.5 to 2.5 % (proportional-action coefficient K <sub>p</sub> : > 200 to 40)	
Air consumption	Type 3766	At 1.4 bar supply pressure	At 6 bar supply pressure
		≤ 230 l <sub>n</sub> /h	≤ 230 l <sub>n</sub> /h <sup>1)</sup>
	Type 3767	≤ 280 l <sub>n</sub> /h	≤ 280 l <sub>n</sub> /h <sup>1)</sup>
Air output capacity	To fill actuator with air	3.0 m <sub>n</sub> <sup>3</sup> /h · K <sub>Vmax</sub> (20 °C) = 0.09	8.5 m <sub>n</sub> <sup>3</sup> /h · K <sub>Vmax</sub> (20 °C) = 0.09
	To vent actuator	4.5 m <sub>n</sub> <sup>3</sup> /h · K <sub>Vmax</sub> (20 °C) = 0.15	14.0 m <sub>n</sub> <sup>3</sup> /h · K <sub>Vmax</sub> (20 °C) = 0.15
Permissible ambient temperature <sup>3)</sup>	Type 3766	Standard	-20 to 80 °C Optional limit contacts/solenoid valve/position transmitter with plastic cable gland
		Low-temperature version	-40 to 80 °C Optional limit contacts/solenoid valve with metal cable gland
	Type 3767	Standard	-50 to 80 °C Optional limit contacts/solenoid valve with metal cable gland
			Standard
		Low-temperature version	-40 to 80 °C Optional limit contacts/solenoid valve with metal cable gland
			Low-temperature version
Influence		Temperature: ≤ 0.3 %/10 K · Supply air: ≤ 1 % between 1.4 and 6 bar	
Electromagnetic compatibility		According to EN 61000-6-2 and EN 61000-6-3	
Effect of vibration		None between 10 and 150 Hz and 4 g	
Explosion protection <sup>2)</sup>		Type of protection II 2G Ex ia IIC T6 or II 3G Ex nA II T6 for Zone 2	
Degree of protection		IP 54 (IP 65 and NEMA 4X possible by fitting a filter check valve. See accessories)	
Compliance			
Weight		Approx. 1 kg	
Materials			
Housing		Die-cast aluminum, chromated and plastic coated Special version: CrNiMo steel 1.4404 (316 L)	
External parts		Stainless steel 1.4571, 1.4305	
Measuring diaphragm		Fluorosilicone (FVMQ)	

<sup>1)</sup> With lowest setting of pressure regulator

<sup>2)</sup> See summary of explosion protection certificates, Table 3 and Table 4

<sup>3)</sup> The limits in the type examination certificate additionally apply to explosion-protected versions

**Table 2: Additional equipment**

Limit contacts				
Two inductive proximity switches		SJ2-SN		
Control circuit		Values according to downstream transistor relay		
Hysteresis at rated travel		≤ 1 %		
Solenoid valve				
Input		Binary DC voltage signal		
Nominal signal		6 V DC	12 V DC	24 V DC
Signal '0' (no response) <sup>2)</sup>		≤ 1.2 V	≤ 2.4 V	≤ 4.7 V
Signal '1' (response) <sup>3)</sup>		≥ 5.4 V	≥ 9.6 V	≥ 18.0 V
Maximum permissible signal		28 V	25 V	32 V
Coil resistance R <sub>f</sub> at 20 °C		2909 Ω	5832 Ω	11714 Ω
Air consumption in steady state		In addition to that of the positioner: OFF ≤60 l <sub>n</sub> /h · ON ≤10 l <sub>n</sub> /h <sup>1)</sup>		
Closing time for rated travel and signal pressure range (K <sub>VS</sub> 0.14)	Type 3277 Actuator	120 cm <sup>2</sup>	240 cm <sup>2</sup>	350 cm <sup>2</sup>
	0.2 to 1 bar	≤ 0.5 s	≤ 0.8 s	≤ 1.1 s
	0.4 to 2 bar	≤ 0.5 s	≤ 2 s	≤ 2.5 s
	0.6 to 3 bar	<sup>5)</sup>	≤ 1 s	≤ 1.5 s
Analog position transmitter <sup>6)</sup>				
Output		Two-wire connection 4 to 20 mA		
Supply air		Minimum terminal voltage: 12 V, max.: 45 V The position transmitter must only be connected to a certified intrinsically safe circuit. <sup>4)</sup>		

<sup>1)</sup> With lowest setting of pressure regulator

<sup>2)</sup> DC voltage signal at -25 °C

<sup>3)</sup> DC voltage signal at +80 °C

<sup>4)</sup> e.g. using a SAMSOMATIC Type 994-0103-KFD2-STC4-Ex1 Loop Isolator

<sup>5)</sup> 120 cm<sup>2</sup> actuator in all signal pressure ranges: ≤0.5 s

<sup>6)</sup> Available until March 2011

**Table 3: Summary of explosion protection approvals for Type 3766**

Type	Certification			Type of protection
3766-1	ATEX	Number	PTB 01 ATEX 2171	II 2G Ex ia IIC T6
		Date	2001-11-26	
3766-1	EAC	Number	RU C DE.08.00697	Type 3766-1: 1Ex ia IIC T6/T5/T4 Gb X Type 3766-8: 2Ex nA IIC T6/T5/T4 Gc X
		Date	2014-12-15	
		Valid until	2019-12-14	
3766-3	CSA	Number	1607848	Ex ia IIC T6; Class I Zone 0; Class I, II, Div. 1, Groups A, B, C, D, E, F, G; Class I, II, Div. 2, Groups A, B, C, D, E, F, G;
		Date	2005-09-16	
3766-3	FM	Number	3020228	Class I, Zone 0 AEx ia IIC Class I, II, III, Div. 1, Groups A, B, C, D, E, F, G Class I, Div. 2, Groups A, B, C, D; Class II, Div. 2 Groups F, G; Class III;
		Date	2005-02-28	
3766-6	IECEx	Number	IECEx TSA 05.0004X	Ex ia I/IIC T6 IP 65, Ex nl/IIC T6 IP 65
		Date	2005-05-24	
3766-8	EAC	Number	RU C DE.08.00697	Type 3766-1: 1Ex ia IIC T6/T5/T4 Gb X Type 3766-8: 2Ex nA IIC T6/T5/T4 Gc X
		Date	2014-12-15	
3766-8	ATEX	Valid until	2019-12-14	II 3G Ex nA II T6
		Number	PTB 01 ATEX 2195 X	
		Date	2002-03-07	

**Table 4:** Summary of explosion protection approvals for Type 3767

Type	Certification			Type of protection
3767	<b>STCC</b>	On request		
3767-1	<b>EAC</b>	Number	RU C DE.08.00697	1Ex ia IIC T6/T5/T4 Gb X Ex tb IIIC T 80°C Db X
		Date	2014-12-15	
		Valid until	2019-12-14	
3767-1	<b>KCS</b>	Number	13-KB4BO-0037	Ex ia IIC T6/T5/T4
		Date	2013-01-31	
		Valid until	2020-01-31	
3767-1	<b>ATEX</b>	Number	PTB 01 ATEX 2167	II 2G Ex ia IIC T6
		Date	2001-11-29	
3767-3	<b>CSA</b>	Number	1607848	Ex ia IIC T6: Class I, Zone 0; Class I, II, Div. 1, Groups A, B, C, D, E, F, G; Class I, II, Div. 2, Groups A, B, C, D, E, F, G;
		Date	2005-09-16	
3767-3	<b>FM</b>	Number	3020228	Class I, Zone 0 AEx ia IIC Class I, II, III, Div. 1, Groups A, B, C, D, E, F, G Class I, Div. 2, Groups A, B, C, D; Class II, Div. 2 Groups F, G; Class III;
		Date	2005-02-28	
3767-6	<b>IECEX</b>	Number	IECEX TSA 05.0004X	Ex ia I/IIIC T6 IP 65, Ex nI/IIIC T6 IP 65
		Date	2005-05-24	
3767-8	<b>EAC</b>	Number	RU C DE.08.00697	2Ex nA ic IIC T6/T5/T4 Gc X
		Date	2014-12-15	
3767-8	<b>ATEX</b>	Number	PTB 01 ATEX 2170 X	II 3G Ex nA II T6
		Date	2003-05-28	

**Mounting the positioner (Type 3766 and Type 3767)**

The Type 3766 and Type 3767 Electropneumatic Positioners can be attached directly to the Type 3277 Actuator (175 to 750 cm<sup>2</sup>) over a connection block. In actuators with “actuator stem extends” fail-safe action, the signal pressure is routed over an internal hole in the actuator yoke to the actuator. In actuators with “actuator stem retracts” fail-safe action, the signal pressure is routed to the actuator over ready-made external piping.

Using the appropriate bracket, the positioner can also be attached according to IEC 60534-6-1 (NAMUR recommendation). The positioner can be mounted on either side of the control valve.

A pair of universal brackets is used for the attachment to Type 3278 Rotary Actuators or other rotary actuators according to VDI/VDE 3845. The rotary motion of the actuator is transferred to the positioner over a cam disk with travel indication.

A special version of the positioner allows it to be attached according to VDI/VDE 3847. This type of attachment allows the positioner to be replaced quickly while the process is running by blocking the air in the actuator. The positioner can be attached directly to the Type 3277 Actuator using an adapter bracket or adapter block. Alternatively, it can be attached to the NAMUR rib of a control valve using an additional NAMUR connection block.

A reversing amplifier is necessary for double-acting, springless actuators for the second opposing signal pressure.

## Electrical connections

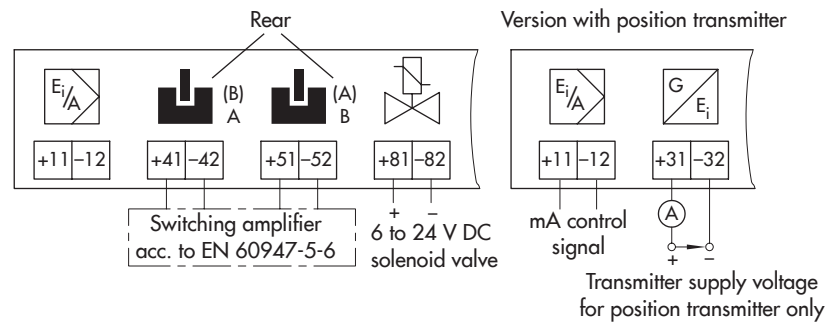

**Fig. 5:** Connection diagram of Type 3766 Pneumatic Positioner

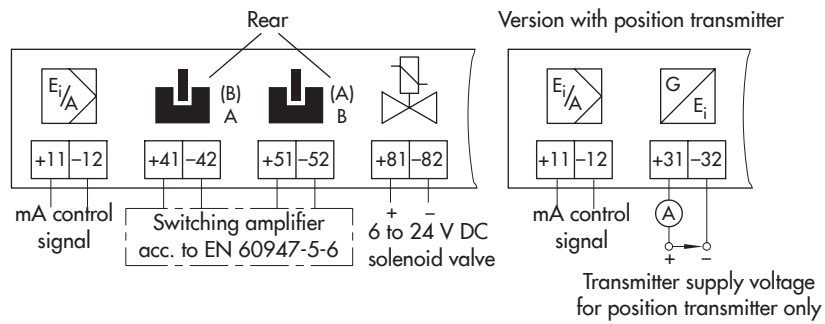

**Fig. 6:** Connection diagram of Type 3767 Electropneumatic Positioner

## Article code for Type 3766 Pneumatic Positioner

Pneumatic positioner	Type 3766-	x	x	x	0	1	x	x	x	x	1	x	0	x	0	
<b>Explosion protection</b>																
Without		0						2								
II 2G Ex ia IIC T6 according to ATEX		1														
CSA/FM intrinsically safe/non incensive		3														
Ex ia/Ex n I/IIC T6 IP 65 IECEx TSA Australia		6														
II 3G Ex nA II T6 acc. to ATEX		8														
<b>Additional equipment</b>																
Without			0													
Inductive limit contacts 2x SJ2-SN			2										0			
(Analog position transmitter 4 to 20 mA) <sup>1)</sup>			6	0												
<b>3/2-way solenoid valve</b>																
Without				0												
6 V DC				2												
12 V DC				3												
24 V DC				4												
<b>Pneumatic connections</b>																
¼-18 NPT							1									
ISO 228/1-G ¼							2									
<b>Electrical connections</b>																
Without (no additional equipment or solenoid valve)			0	0				0	0							
Plastic cable gland M20 x 1.5, blue								1	0				0			
Plastic cable gland M20 x 1.5, black								2	0				0			
Cable gland M20 x 1.5, nickel-plated brass								2	1				3			
<b>Housing version</b>																
Die-cast aluminum										0						
CrNiMo steel										2						
<b>Temperature range</b>																
Standard													0			
Low-temperature version																
T <sub>min</sub> ≥ -50 °C; optional limit contacts, solenoid valve								2	1				3			
<b>Special versions</b>																
Without														0	0	0
GOST Ex approval 0Ex ia IIC T8 X														0	1	0

<sup>1)</sup> Available until March 2011

Device functioning only as analog position transmitter: 3766-x60 000xxx00 000 0



## Article code for Type 3767 Electropneumatic Positioner

Electropneumatic positioners	Type 3767-	x	x	x	0	1	x	x	x	x	x	x	0	0	0		
Explosion protection																	
Without		0						2									
II 2G Ex ia IIC T6 according to ATEX		1															
CSA/FM intrinsically safe/non incendive		3															
II 3G Ex nA II T6 acc. to ATEX		8															
Additional equipment																	
Without		0															
Inductive limit contacts 2x SJ2-SN		2															
(Analog position transmitter 4 to 20 mA) <sup>1)</sup>		6	0									0					
3/2-way solenoid valve																	
Without			0														
6 V DC				2													
12 V DC					3												
24 V DC						4											
Type of mounting																	
Standard range spring					0	1											
Pneumatic connections																	
¼-18 NPT							1										
ISO 221/1-G ¼								2									
Electrical connections																	
Plastic cable gland M20 x 1.5, blue								1	0								
Plastic cable gland M20 x 1.5, black									2	0							
Cable gland M20 x 1.5, nickel-plated brass										2	1						
Housing version																	
Die-cast aluminum											1						
CrNiMo steel												2					
Reference variable																	
4 to 20 mA													1				
0 to 20 mA														2			
1 to 5 mA															3		
Temperature range																	
Standard														0			
Low-temperature version																	
T <sub>min</sub> ≥ -45 °C; optional limit contacts, solenoid valve									2	1					2		
Special versions																	
Without															0	0	0

<sup>1)</sup> Available until March 2011

Direct attachment to Type 3277 Actuator

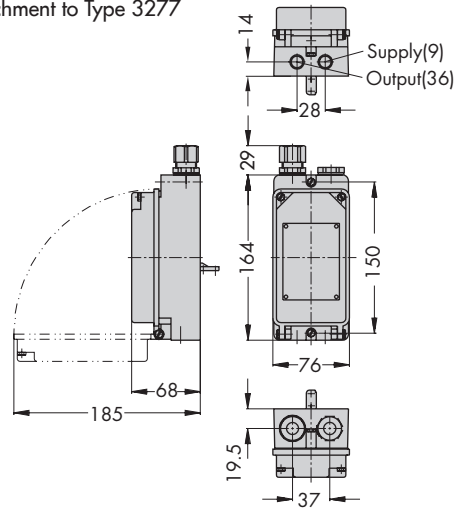

Attachment according to DIN EN 60534 and NAMUR

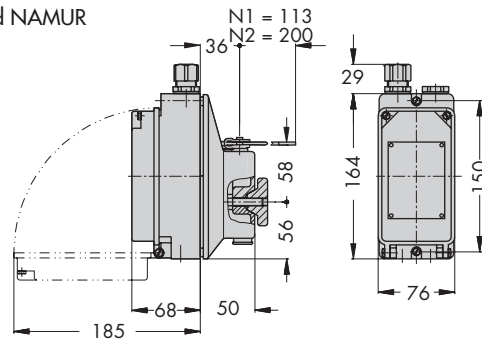

Attachment to rotary actuators (with pneumatic reversing amplifier)

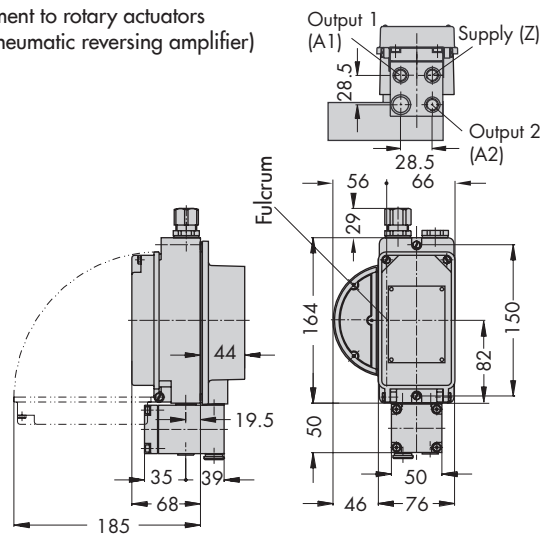

### Ordering text

Type 3766 Pneumatic Positioner

or

Type 3767 Electropneumatic Positioner

### Accessories

- NPT adapter for electrical connections
- Range spring 2
- Filter check valve in housing with G 1/4 thread
  - Polyamide, IP 65 degree of protection
  - 1.4301, IP 65 degree of protection
  - Polyamide, NEMA 4 degree of protection
  - 1.4301, NEMA 4 degree of protection

### Additional specifications

- Without/with pressure gauges for signal pressure and supply air
  - For mounting on the control valve
- Adjusted reference variable
  - Direction of action: increasing/increasing or increasing/decreasing
- Positioners with inductive proximity switches:
  - Metal tag outside the inductive field: contact closed
  - Metal tag inside the inductive field: contact open
- Direct attachment to Type 3277 Actuator (120 to 700 cm<sup>2</sup>)
- Attachment according to IEC 60534-6 (NAMUR)
  - Travel: ... mm, if applicable, rod diameter: ... mm
- Attachment to Type 3278 Rotary Actuator (160 or 320 cm<sup>2</sup>)
- Attachment to rotary actuators according to VDI/VDE 3845
  - Single acting or double acting
- Linear or equal percentage characteristic
- Opening angle 70°/75°/90°

Refer to the Mounting and Operating Instructions ► EB 8355-1 (for Type 3766) or ► EB 8355-2 (for Type 3767) concerning the mounting parts required when the positioner is delivered separately and not mounted onto a control valve.

